



[High Quality Original Manuals for you](#)

[Visit us on the Internet](#)
sales@manuals-for-you.com

***Strata*[®] DK280**
PROGRAMMING PROCEDURES

CHAPTER 2
INSTRUCTIONS

Strata[®] *DK280*
PROGRAMMING PROCEDURES

**CHAPTER 2
INSTRUCTIONS**

IMPORTANT!

System configuration can be complex and time consuming. For best results:

Use the software program "280 QUOTE" to provide easy, fast, automated configuration. This runs on an IBM compatible 286 PC, or higher, with a hard disk.

If the above software is not available, use all the Configuration Worksheets in Chapter 2 of the Installation Manual, Section 100-280-202.

IMPORTANT INSTALLATION NOTES:

- 1. Place the RCTU jumper plug into Battery position; otherwise, all programmed data will be lost upon power down.**
- 2. Install PDKU or PEKU in slot 11.**
- 3. Install all Station, Loop Start and Ground Start PCBs from lower to higher numbered slots (left to right). Do not leave empty slots.**
- 4. If DID or TIE T1 channels are used (or anticipated in the future), install RDTU PCBs in the highest numbered slots available. See Installation Section, Chapter 2, Worksheet 2, Tables B and C for slot information details. T1 with only Ground or Loop start channels can be installed as in Step 3 above.**
- 5. Install DID and TIE line analog PCBs starting from the highest numbered vacant slot to the lowest needed (in right to left order).**
- 6. Install PIOU, PIOUS, PEPU in any convenient vacant slot.**
- 7. Check Power Factors for each cabinet and for the entire system as explained in the Configuration Chapter of the Installation Section (100-280-202) of this manual.**
- 8. If needed, run Program 91-9 twice to initialize Program data. This must be done if you have just completed step 1 above.**

TABLE OF CONTENTS

PARAGRAPH	SUBJECT	PAGE
1	General -----	2-1
1.10	System Record Sheet Data Entry -----	2-1
1.20	Basic System Record Instructions -----	2-1
2	Toll Restriction -----	2-22
3	Toll Restriction Overview -----	2-22
3.00	Toll Restriction Methods -----	2-22
3.10	Toll Restriction Features -----	2-22
4	Completing the Toll Restriction System Record -----	2-22
4.10	Program 44-1 ~ 8—Toll Restriction/Traveling Class Override Codes -----	2-23
4.20	Program 45-1—Toll Restriction Dial Plan -----	2-23
4.30	Program 45-2—Toll Restriction Disable -----	2-24
4.40	Program 45-3 ~ 6—Equal Access/Special Common Carrier Numbers and Authorization Code Digit Length -----	2-24
4.50	Program 45-8 ~ 9—Toll Restriction Override Code -----	2-24
4.60	Program 46-2 ~ 4—Toll Restriction Allowed/Denied Area Codes Assigned by Class -----	2-25
4.70	Program 46-6 ~ 8—Toll Restriction Allowed/Denied Office Codes Assigned by Class -----	2-25
4.80	Programs 46-10 ~ 80 & 46-11 ~ 81—Toll Restriction Class Parameters (Class 1 ~ 8) -----	2-25
4.90	Program 47—Toll Restriction Exception Office Codes Assigned by Area Codes -----	2-25
4.100	Program 48—Station Toll Restriction Classification -----	2-26
5	Least Cost Routing -----	2-27
6	Least Cost Routing Overview -----	2-27
6.00	Definition -----	2-27
6.20	Conditions -----	2-28
7	Completing the Least Cost Routing System Record -----	2-28
7.10	LCR CO Line Programming Reference Table -----	2-28
7.20	Program 50 Series—LCR Definitions -----	2-28
7.30	Route Plan Overview -----	2-29
7.40	Program 55 Series—LCR Modified Digits Tables -----	2-31

FIGURES

FIGURE	TITLE	PAGE
2-2	LCR Operational Block Diagram -----	2-33

STAR (*) PROGRAMS

Among the new programs and program enhancements introduced with the STRATA DK280 are the “* programs.” Programs *09, *15, *17, *29, *30, *31, *41-1, *41-2, *41-3, *41-4, *42-1, and *42-2 comprise the “* programs,” which get their name from the requirement that the * button on the telephone must be keyed in when entering these programs. When entering Program *09, for instance, the * button must be entered before keying in 0 and 9. (See the top of the Program *09 System Record Sheet.)

Other than the entry sequence, there is nothing different about the “* programs.” Data is entered in the same way as in other programs. The “* programs” belong to the Basic System category of programs and do not relate to Toll Restriction or Least Cost Routing. Instructions for the “* programs” appear with each program, preceding the Toll Restriction instructions. The System Record Sheets for the “* programs” fall in the same order.

The “* program” record sheets and programming instructions follow programs that have the same number: Program *09 follows Program 09, Program *31 follows Program 31, etc.

IMPORTANT NOTE:

When initializing range programs, all star “*” programs follow Program 97 in system memory; so if Programs 29 through 32 are entered as the range (00 * 32), Programs *29, *30, and *31 will not be initialized—the range (*29 * *31) must be entered to include the star Programs *29, *30, and *31 in the range.

CHAPTER 2

INSTRUCTIONS

1 GENERAL

1.00 This chapter consists of System Record Sheets and instructions on how to fill out each of them. The chapter begins with the instructions: first the basic program instructions, followed by Toll Restriction and Least Cost Routing instructions. The remainder of the chapter contains the System Record Sheets, organized in the same sequence as the instructions.

1.10 SYSTEM RECORD SHEET DATA ENTRY

1.11 The System Record Sheets are used to record the assignment of features or the operation of each program. Each sheet provides space to record data. This data will be referred to when programming the system. The following consists of descriptions of each of the programs available with the STRATA DK280.

1.12 Initialized data information can be found in the Notes at the bottom of each System Record Sheet.

1.20 BASIC SYSTEM RECORD INSTRUCTIONS

Program 91-9 System Initialization: Always initialize a system with Program 91-9 when it is first installed or when its software must be brought to the default configuration. Program 91-9 will erase all random or programmed data in all STRATA DK280 software programs and set all program data to the default value. Program 91-9 will also automatically run all other initialization programs: 91-1, 90 (00 ~ *99), 92 (1 ~ 9).

WARNING!

Program 91-9 will erase all program data and it will drop all calls if it is run while the system is in service.

If only minor programming changes are being added to a system in which the programming is basically correct, skip this section.

Follow the steps in Table 1-C and in the Program 91-9 record sheet to run Program 91-9.

1. Ensure that the system meets minimum hardware requirements specified in Paragraph 3.32.
2. Place the system power switch in the ON position.
3. Follow the steps in Table 1-C.

Program 91-1—Automatic PCB Recognition and Port Renumber: This program should be run during an initial installation after all of the PCBs have been

installed to automatically make PCB slot code assignments. This program only applies to slots in which non-optioned PCBs are installed—such as the PDKU without a Data Interface Unit or Off-hook Call Announce (OCA), the Common Control Unit (RCTUA, RCTUB, RCTUC/RCTUD) without a Dual-tone Multi-frequency Receiver (RRCS), etc. For slots that have PCBs equipped with options, Program 03 must be run after Program 91-1. Program 91-1 can be run after PCB option codes have been set with Program 03; it will not erase option codes. Program 91-1 can also be run to set physical port and logical ports to the initialized settings. (See Program 04 for initialized settings.)

Program 90—Initializing Programs: All customer data can be cleared and set to the initialized state for any program or range of programs. If the system is being installed for the first time, this program **must be run** to erase random data from RAM which may have been caused by the Common Control Unit (RCTUA, RCTUB, RCTUC/RCTUD) jumper movement to the internal battery. Initialized data information can be found at the bottom of each System Record Sheet. If the system is being installed in a new location, all programs should be initialized. Running Program 91-9 automatically runs Program 90.

Program 92—Initializing Speed Dial Numbers, VM ID Codes, Character Message Memory, Timed Reminders, Digital Telephone Volume Levels, and Call Forward Memory: All previously entered or random data (of the type listed) is cleared by this program. This program **must be run** when first installing a system or a Common Control Unit (RCTUA, RCTUB, RCTUC/RCTUD). Running Program 91-9 automatically runs Program 92 (1 ~ 9).

Program 03—Flexible PCB Slot Assignments: After running Program 91-1 or 91-9, the software must be informed with Program 03 as to what type of optioned PCBs are installed. Use the PCB Code Reference Table on the **Program 03** record sheet to determine the proper option code for each PCB with an option. When entering an option code for the RCTUA, RCTUB, or RCTUC Common Control Unit, always enter the code for Slot 00. When entering an option code for the RCTUD unit, always enter the code representing the number of DTMF receivers installed for Slot 01. The Program 03 System Record Sheet provides space to record station ports assigned to the station, TIE, and DID line PCBs and line numbers assigned to the CO, TIE, and DID line PCBs. Program 03 should be run for the slot of each new PCB when installing a new PCB in an existing installation. This record sheet is the main record for the hardware configuration of the entire system.

WARNING!

Running Program 91-9 will erase Program 03 option codes. Running Program 91-1 will not.

IMPORTANT NOTE!

After the complete entry of Program 03, turn the KSU power supply switch off and wait five seconds before turning it back on. This will set in memory all of the configuration data entered in Program 03.

Program 00—Software Check/Remote Maintenance Security Code Assignments:

- **Code 0, ROM Version**—Code 0 displays the software version of the system Common Control Unit (RCTUA, RCUTB, and RCTUC/RCTUD). See the Program 00 record sheet for an illustration of software displays. This information cannot be altered with this program.
- **Code 1, Level 1 Security Code**—Use this program to assign a Remote Maintenance security code that allows entry to all programs and data.
- **Code 2, Level 2 Security Code**—Use this program to assign a Remote Maintenance security code that allows entry to Programs 30 ~ 39, 77 ~ 89, and *30 ~ *31.
- **Code 8, Software RAM Checksum**—For factory purposes only.
- **Code 9, Power OFF Counter**—For factory purposes only.

Program 01—Logical Station Port Display and Change: This program enables the programmer to enter a physical port to display the associated logical port. The programmer then has the option to assign a new logical port to the physical port. (To return ports to their initialized settings, see Programs 90 and 91.)

Program 02—Physical Station Port Display and Change: This program enables the programmer to enter a logical port to display the associated physical port. The programmer then has the option to assign a new physical port to the logical port. (To return ports to their initialized settings, see Programs 90 and 91.)

Program 03 (see previous page)

Program 04—Port/Station Number Assignment: Initialized station numbers are 200 ~ 439. Door phone standard numbering is #151 ~ #159 and #161 ~ #163; the internal modem (IMDU) is #19. Port 039 (RCTUA), 089 (RCTUB) or 249 (RCTU C/D) is the DISA class of service port. Station intercom numbers can be changed using Program 04, but door phone and modem numbering cannot be changed

with **Program 04**. Only the first digit can be changed by using **Program 05**. The system automatically assigns door phone station numbers if a door phone is specified in **Program 77-1**. Station number assignment is fully flexible so that each station can have any number assigned up to four digits. All STRATA DK280 telephone and data interface unit user guides are written using the standard access codes and station numbers. If desired, a telephone accompanying a DSS console can have a station number of 0 or 01, etc., without conflict. If no assignment is made in **Program 04**, the system, upon powering up, will automatically assign eight station numbers for each station PCB installed and four for each PEMU, REMU, RDDU, and RATU PCB. Each RDTU TIE, and DID channel is also assigned a station port. This is done in sequence of ascending slot numbers for station numbers 200 and up. Attendant consoles will ring on the ICI "0" button for Dial "0" calls, and on the Intercom key when the Intercom number assigned to the console (station) port in this program is dialed.

Program 05—Flexible Access Code Numbering: The first digit of a feature access code may be changed to a different digit or to two digits. Digits after this prefix cannot be changed. Standard access codes are provided with the **Program 05** System Record Sheet. Some access codes cannot be changed (such as the code for Automatic Callback) and are shown with N/A on the record sheet. **Access code conflicts may exist if new access codes are assigned**, and a new system numbering plan will have to be carefully worked out. Pay particular attention to the internal modem (station number #19) and door phones (#151 ~ #159, #161 ~ #163). Station number assignments may have to be changed using **Program 04**.

Program 09—Built-in Auto Attendant Prompt/Station Assignments: This program tells the system where to direct calls after incoming Auto Attendant Callers dial a digit or digits in response to the menu of dialing prompts offered them by one of the Auto Attendant's digital announcers. The exact dialing prompts along with their associated station numbers are assigned with this program—the actual announcements that are delivered to callers are recorded on customer-supplied digital announcers. The dialing prompts can either be all one-digit or all two-digit (or intercom numbers 1 ~ 4 digits).

- As many as seven one-digit dialing prompts (0, 1, or 5 ~ 9) can be assigned. Digits 2, 3, and 4 are not used, because they conflict with the system's default intercom numbers. To program one-digit dialing prompts, enter the prompt and then its associated intercom number (200 ~ 439 or #4 plus an ACD group number).

- Two-digit dialing prompts are only used when it is necessary to stop the announcement to prevent errors in digit translation. Sometimes when line transmission is low or the announcement voice frequencies are the same as a DTMF digit, the system RRCS circuit will not dial or it will misdial. The first of the two digits can be either digit 0, 1 or 5 ~ 9 and must always be the same number for each of the prompts. Therefore, if the leading digit is assigned as 5, callers could be offered all of the following two-digit dialing prompts: 50, 51, 52, 53, 54, 55, 56, 57, 58, and 59. See the Record Sheet for Program 09 for detailed one-digit and two-digit prompt assignment instructions.

Program *09—DID Digit Translation Assignments:

The CO sends 2-4 DTMF digits to the DK280 DID line when external callers call into the DK280 on a DID line. The digits are called the DID extension number. The installer must find out which extension numbers will be sent to the DK280 on DID line calls and assign them to DK stations (Ports) or ACD Groups (R2). This program assigns DID line extension numbers to ring stations, Attendant Consoles, and ACD Groups. For each logical port (station), record the extension number that should be dialed to ring it on DID calls on the Program *09 System Record Sheet. Each DID line extension number can only ring one station; however, a DID extension number will alternately ring all or selected Attendant Consoles (Load Sharing) when a DID extension number assigned any one of the Attendant Consoles (in the Load Share Console Group) is dialed. (See Section 100-280-206, Paragraph 8.20 for Attendant Console Load Share Programming.) After the DID line extension number is dialed by the caller, the call will be routed to the station assigned to the extension number in this program. Port 035 (RCTUA), Port 085 (RCTUB), and Port 245 (RCTUC/RCTUD) assign extension numbers to the IMDU maintenance modem for DID lines. See the *DK280 ACD I&M Manual* to assign DID digits to ACD groups.

Program 10-1—System Assignments 1: The following options are available on a system-wide basis: (LEDs 07, 08, 09, 18, 19, and 20 are initialized as ON.)

- **Two Line Conference, LED 20**—Two lines can be conferenced with one or two telephones (digital, electronic, or standard). Conference (see LED 19) in this program must be enabled for this feature to work. Also, Two-line Conference must be allowed for Direct Inward System Access (DISA) use of outgoing lines.
- **Conference, LED 19**—The ability of stations to perform any Conference can be allowed or disallowed system-wide with LED 19.
- **Ring Detect Time, LED 18**—This should be set to "normal" unless connected to Central Office/CENTREX lines that send ring signals less than 120 milliseconds.
- **Intercom Volume PAD, LED 17**—ON reduces station-to-station intercom volume. LED 17 should be OFF in all cases except where extreme quiet room noise is expected.
- **ABR Cycles, LED 12**—If activated from an electronic or digital telephone, Automatic Busy Redial will retry dialing a telephone number on a line if a far end busy signal is detected. Turn LED 12 ON to have the system try up to 10 times: turn OFF for up to 15 attempts. This feature is not available with standard telephones.
- **ABR Redial Time, LED 11**—Upon detection of a far end busy signal on a line, Automatic Busy Redial will retry either once every 30 seconds or once every minute. Turn LED 11 ON for 30 seconds; turn OFF for one minute.
- **System Speed Dial Override, Toll Restriction, LED 10**—System Speed Dial can be chosen to override Toll Restriction if LED 10 is turned ON.
- **Exclusive Hold, LED 09**—Exclusive Hold allows electronic and digital telephones to place calls on hold (by pressing the **Hold (HOLD)** button twice) so that other stations cannot pick up the held call with a CO line button. This feature can be disabled on a system-wide basis. Any station can pick up an exclusive hold call by using the call pickup code.
- **Alternate Point Answer/Transfer Privacy, LED 08**—If Transfer Privacy is selected, a transferred call can only be answered at the called station upon transfer of that call. With Alternate Point Answer, any electronic or digital telephone with the appropriate CO line button can pick up a call transferred to another telephone. In either case, Call Pickup will function from any station.
- **Ring Transfer, LED 07**—This option defines station operation for transferring line calls. If Ring Transfer is allowed, the system will allow "blind" transfers to busy or idle stations—the transferring station may release a transferred call before the called party answers. If not allowed, the system will allow supervised transfers only—the called station must answer before the transferring station releases. If Ring Transfer is not allowed, immediate recall occurs if "blind" transfer is attempted. The system denies Ring Transfer to stations in the Do Not Disturb (DND) mode, and immediate recall will occur if it is attempted.
- **Line Repeat Ringing, LED 06**—If selected, the incoming ringing timing pattern at a station will be the same as the CO line ringing pattern. This is used mainly with CENTREX or PBX systems which may vary the ring pattern to distinguish between intercom and incoming calls, etc. If Standard Ringing is chosen, CO line station ringing will be a one second on, three seconds off

cycle regardless of the incoming ring pattern. Some Central Offices have ringing characteristics such that this option would not be desirable.

- **Incoming Call Abandon Timing, LED 05**—The amount of time between incoming CO line ring signals determines when the system will discontinue (abandon) sending ringing tones to stations. The choice of six or eight seconds is dependent on the line ring pattern. This assignment has no affect if the Line Repeat Ringing (LED 06) option is used.
- **Dual-tone Multi-frequency (DTMF) Signal Time, LED 04**—DTMF signals sent out to CO lines can be either 80 or 160 milliseconds in length. DTMF to RSTU/RDSU/RSTS/PSTU/PESU ports (including voice mail ports) are not affected by this assignment. See Program 10-2 for standard telephone port DTMF timing. This program pertains to manual dialing or speed dialing from all Toshiba telephones, except when manually dialing from 2000-series Digital Telephones. When manually dialing from 2000-series phones, the signals last as long as the buttons are pressed (minimum 80 msec.).
- **Dial Pulse (DP) Make Ratio, LED 03**—Dial Pulse timing sent out to CO lines can be changed from the normal 40% make ratio to 33%. This selection only applies to those CO lines assigned in Program 15 to signal dialing with dial pulse instead of Dual-tone Multi-frequency (DTMF).
- **Line Reseize Guard Time, LED 02**—Should be set for 0.45 seconds for most installations. Set guard time for 1.5 seconds (using Program 10-1, LED 02 ON, and Program 42-0), if CO lines experience the following situations: no dial tone when a line is released and reseized immediately; or, when operating behind CENTREX or PBX, false hookflash signals are sent to the Central Office when stations release and reseize the same line immediately.
- **Tone First/Voice First Signaling-Electronic and Digital Telephone, LED 01**—With Voice First, an intercom call to an electronic or digital telephone will be preceded by a one second burst of tone, followed by voice communication via the Handsfree Answerback function. For Tone First, repetitive intercom ring tone is sent in a one-second on, three-seconds off pattern. Conversion from one signaling mode to the other can be made by dialing an additional digit of 1 from the calling station.

Program 10-2—System Assignments 2: The following options are available on a system-wide basis: (LEDs 02, 14, 15, and 16 are initialized as ON.)

- **Single Tone Return, LED 20**—With some Central Offices, callers may experience clicking or squealing sounds during or after dialing. To counteract this noise, it is recommended that single

tone return or no tone return be enabled: (LED 20 ON; or, No DTMF Tone return: LED 20 OFF and LED 11 ON). The optional single frequency system tone will be returned to callers with each digit dialed from the telephone dial pad or when speed dialing is used. The tones will also be heard by callers routed to voice mail when DK280 sends VM ID codes. If this option is not selected, Program 10-2, LED 11 will select DTMF Return or No DTMF Return.

- **Stations Use External Amplified Conference, LED 19**—Use this feature only (LED 19 ON) if an external amplifier (Program 10-3) is used for Two-Line Conference calls. This will provide additional amplification to the station during a Two-line Conference call. If an external amplifier is not switched into Two-line Conference calls in all cases, LED 19 must be OFF if there is line unbalance which may cause "HUM" noise on the station talk path during Two-line Conference calls. It is recommended to test Two-line Conference with LED 19 ON; if there is no HUM noise, keep LED 19 ON.
- **Two-CO Line Conference, LED 18**—LED 18 should be OFF whenever Two-line (Tandem, External Call Forward, DISA, TIE) connection is allowed (in Program 15-5 and Program 10-1, LEDs 19 and 20) unless two-CO-line conference amplifiers are connected (Program 10-3, LED 01 ~ 04). This will increase the volume level between the two outside parties on a Tandem (two-line) connection; but, it will not affect station volume if conferenced into the tandem connection.
- **"TRNS" Soft Key Immediate Transfer, LED 17**—If this feature is activated and a transfer is initiated with the "TRNS" Soft Key, the call will ring transfer (Camp-on Busy) immediately after the last digit of the called station (busy or idle) number is dialed. This feature does not apply to transfers initiated with the fixed **Cnf/Trn (CONF/TRNS)** button or "CONF" Soft Key.
- **Executive Override Warning Tone, LED 16**—Executive Override allows a station user (if assigned in Program 30) to break into and overhear an existing station conversation. A warning tone can be set optionally to be heard by the conversing parties.
- **External Page Included with All Call Page, LED 15**—If the All Call voice page access code (#39) is dialed, external page (all zones) may be included with this option. This option does not affect the All Call Page button function, which activates electronic and digital telephone speakers only, never external page.
- **Privacy Override Warning Tone, LED 14**—Privacy Override allows a station user to enter into, and overhear, an existing CO line conversation by pressing a CO line button (if the called station is assigned in Program 30). A warning tone

can be set optionally to be heard by the conversing parties.

- **Auto Callback Camp-on Tone, LED 13**—A busy called digital or electronic telephone user may optionally hear a one-time beep tone (from the speaker) signifying that another station has tried to call and has activated the Automatic Callback feature.
- **CO Line Beep Tone, LED 12**—If this LED is lit, a beep tone will be sent every three minutes to stations on outgoing line calls.
- **Dual-tone Multi-frequency (DTMF) Tone Return, LED 11**—This option deletes DTMF tones that are returned to digital or electronic telephones when manually dialing or speed dialing. It also eliminates auto dial digits returned to callers when digits are automatically sent to voice mail ports on forwarded calls.
- **Background Music/Music-on-Hold Separation, LEDs 10 and 9**—An alternate Background Music (BGM) source can be sent to digital telephone speakers, electronic telephone speakers, and external page speakers, while another Music-on-hold (MOH) source can be sent to lines or internal stations on hold. The alternate BGM source can be connected to either Circuit 3 on a PEKU PCB, Circuit 8 on a PESU PCB, or Circuit 2 on a PSTU, RDSU, or RSTU. LEDs 09 and 10 should be off for RSTU, RDSU, and PSTU alternate BGM. The MOH source always connects to the Common Control Unit (RCTUA, RCTUB, RCTUC/RCTUD). Also run Program 19 to assign BGM to a PCB slot number.
- **Display Dialed Number Timing, LED 08**—An LCD telephone will display a dialed number on outgoing calls and the CO line ID name on incoming calls for either 15 or 60 seconds before the display changes to the elapsed time of the call.
- **Standard Telephone Distinctive Ring, LED 07**—The line call ring pattern to standard telephones can be made distinct from the intercom ring pattern. If Distinctive Ring is enabled, the CO line call ring pattern will be 0.2-seconds on, 0.4-seconds off, 0.2-seconds on, 3.4-seconds off; if Distinctive Ring is not enabled, the pattern will be per Program 10-1, LED 06. Intercom, Transferred, TIE, and DID calls, with or without Distinctive Ring enabled, ring with a one-second on and 3-seconds off pattern.
- **Voice Mail Identification Code, Dual-tone Multi-frequency (DTMF) Signal Time, LED 06** — DTMF digits automatically sent to RSTU/RDSU/RSTS/PSTU/PESU voice mail ports can be sent in either 80- or 160-millisecond bursts. This applies to digits sent via the voice mail identification code (#656/#657) set at each station. This also applies to manually dialed digits sent to voice

mail ports from Toshiba telephones, including 2000-series Digital Telephones.

- **Voice Mail Message Waiting Cancel Via Dial # 6 4/Automatic, LED 04**—“RS-232 or Dial # 6 4” should be enabled if the DK280 system is connected to a voice mail (VM) system that sets station Message Waiting (MW) LEDs by RS-232 or by dialing # 6 3 + station number or RS-232 signal. This insures the message LED remains flashing until the VM machine cancels the Message LED by sending an RS-232 signal or dialing # 6 4 + station number. With “RS-232 or Dial # 6 4” enabled, message indications set on a station from VM ports will not automatically be cancelled by the DK280 system when the station calls Voice Mail to retrieve messages. If “Automatic” is selected, the flashing message waiting LED is canceled any time a station calls the VM machine and the VM machine answers.

NOTE:

When using RS-232 Voice Mail Integration (Toshiba or SMDI) LED 16 must be set to ON in Program 31, for PGM 10-2 to function.

- **Ringling Modes, LED 03**—The STRATA DK280 system can be set for either two-ringing-mode or three-ringing-mode operation. The DAY and NIGHT modes are available with the two-mode operation, and the DAY, DAY2, and NIGHT modes are available with the three-mode operation. Each ringing mode has distinct CO line ring assignments (Programs 78, and 81 ~ 89). The three-mode selection is useful for alternate answering positions. Station users can change modes with the Night Transfer button on either a DSS console (Program 29) or a telephone (Program 39). This feature applies to Loop and Ground start lines only, not TIE or DID lines.
- **Call Forward / Station Hunt Override From DSS Console, LED 02**—If a station has activated Call Forwarding or Station Hunting, all calls to that station—except for calls from the DSS console position—will forward or hunt to another number. A choice exists of whether to call forward from the console itself or from the digital or electronic telephone assigned to it. If the console calls (using the DSS console station buttons) are forwarded, the attendant telephone will not be forwarded, and vice versa. This allows the console operator flexibility in reaching a station user.

NOTE:

This feature applies to both types of DSS consoles, the DDSS and the HDSS.

- **Tone First/Voice First-DSS Console, LED 01**—The intercom call signal from a DSS console can be set for Tone First Signaling or Voice First Signaling. This setting is independent of the system-wide signal option in Program 10-1. Thus, DSS consoles and their attendant stations can ring with different signaling modes.

Program 10-3—System Assignments 3: The following options are available on a system-wide basis: (ALL LEDs are initialized as OFF.)

■ **Speed Dial Entry Timeout, LED 19**—Station users can either have up to one minute or up to three minutes to store a Speed Dial number or memo. If they fail to store the number or memo within the set time, their station will exit the Speed Dial-storage mode and return to the normal idle state. The timer is required because of the User Programmable Feature Buttons feature, which allows the **Intercom (INT)**, **Hold (HOLD)**, and **Cnf/Trns (CONF/TRNS)** button functions to be programmed in Speed Dial Memory. The three-minute setting is recommended if station users will frequently be storing memos with Speed Dial numbers using the MODE key below the Liquid Crystal Display (LCD).

■ **Built-in Auto Attendant Camp-on Busy/Ring No Answer Routing, LED 18**—This program—which is designed for Auto Attendant configurations that have primary announcement devices, but no secondary ones—tells the system where to route Auto Attendant calls that ring and are not answered or have been camped-on for a designated time (see Program 26). The calls can be sent back to the primary announcement device or to the station or stations assigned to the CO lines' normal ringing pattern (see Programs 81, 84, and 87).

■ **Built-in Auto Attendant Disconnect Time, LEDs 16 and 17**—If LED 18 is assigned for normal ringing, set LEDs 16 and 17 to tell the system when to disconnect Built-in Auto Attendant calls that have not been answered by the alternative stations. This feature assures that the loop start CO line that the call was made on will be free for other calls if the caller hangs up before answered. The initialized disconnect setting is 40 seconds. The other timing options available are 150 seconds and 350 seconds. Set LEDs 16 and 17 for the desired time as follows:

40 seconds: LED 16 = Off. LED 17 = Off.

120 seconds: LED 16 = Off. LED 17 = On.

240 seconds: LED 16 = On. LED 17 = Off.

■ **Built-in Auto Attendant MOH/RBT for Transfer, LED 15**—Callers can hear ring back tone (RBT) or Music-on-hold (MOH) after being transferred from the Built-in Auto Attendant to a station, depending on the selection made with LED 15.

■ **RS-232 Voice Mail Signaling Method (LED 14):** The DK280 provides two types of RS-232 signaling: Bellcore Standard type (TR-TSY-000283, TR-NWT-000283) or Toshiba Proprietary. Refer to the VM machine installation documentation and contact the Toshiba and/or VM machine manufacturer for VM machine SMDI configuration.

NOTES:

1. *Toshiba VP products require Release 7 software or above for Toshiba proprietary integration.*
2. *Toshiba VP products require the "SW-X0042 feature package (C.O. Centrex) for SMDI, but not for Toshiba Proprietary RS-232 Interface.*

■ **SMDI Station Number Digit Length (LED 13-10):** This refers to the station digit length that the SMDI voice mail system design requires. This parameter is set for the Voice Mail system digit length; not the DK280 station digit length. If the voice mail system SMDI is designed per the Bellcore Standard TR-TSY-000283, 1985 version, set this parameter to 7-digits (LEDs 10, 11, and 12 "On" which is equal to HEX 7). Current VP Voice mail SMDI systems are designed for this 7-digit operation. If the voice mail system SMDI is designed per the Bellcore Standard TR-NWT-000283, 1991 version, set this parameter between 1-10 digits with LEDs 10, 11, 12, and 13. (See **Program 10-3** record sheet for LED-HEX values.) Digit length setting is not necessary with Toshiba Proprietary Interface (LED 10-13 OFF).

■ **SMDI Bellcore Standard Version (LED 09):** Bellcore released two versions of the SMDI specification. Contact your voice mail machine vendor to determine which specification to enable with this program – TR-TSY-000283, Issue 1, July 1985 version, or the TR-NWT-000283, Issue 2, May 1991 version. Toshiba VP SMDI products currently use the 1985 version. In either case, the VM station digit length must be set with LED 10-13 as shown above. Also note that the 1985 and 1991 version Bellcore specifications use different space/character parameters for some call types which means the DK280 will not operate properly if the correct version is not selected. Select the 1985 version (LED 09 OFF) for VP products. This selection is not necessary with Toshiba Proprietary Interface (LED 09-OFF).

■ **Amplified Conference Assignments (LED 01 ~ 04):** Light LEDs 01 ~ 04 to identify which PEKU ports should be connected to external amplifiers. External Amplified Conference is provided by customer-supplied two-way amplifiers connected to system PEKU ports to provide amplification of "two-line" calls. Up to four amplifiers can be connected (two PEKU ports for each amplifier) to amplify up to four two line calls simultaneously with RCTUB and C/D, three with RCTUA. The amplifier is switched into the call automatically when a two-line call is established. Amplifiers are switched into calls starting from the lowest PEKU ports to the highest (see Program 10-3 System Record Sheet). Skipping PEKU ports is allowed.

Example: The first amplifier can be connected to PEKU ports 017 and 018, skipping ports 009 and 010. In this case, LED 02 should be ON and LED 01 should be OFF. (See Program 10-1, LEDs 19 and 20; Program 10-2, LEDs 18 and 19; and Program 15-5 for more information regarding Two-line Conference.)

IMPORTANT NOTE!

A DK280 system operating with the RCTUB or RCTUC/RCTUD Common Control Unit allows up to 10 simultaneous Two-line Conference connections (four with the RCTUA). The amplifiers are switched in automatically starting with the first connection. Calls made when there are no amplifiers available will not be amplified.

NOTE:

The external amplifiers will also amplify two-line DISA, CALL Forward External, and TIE line calls.

Program 12—System Assignments-Basic Timing:

(Initialized data for Program 12: Code 3 = 1, Code 4 = 2, Code 5 = 0, and Code 9 = 4.)

- **Pause Timing, Code 3**—Short and long pauses may be programmed in Speed Dial numbers by station users. The short pause length can be set system wide for either 1.5 or 3 seconds with this program. The long pause length is always 10 seconds.

NOTE:

This program applies to Speed Dial numbers used for both voice and data calls. Data call pause length is determined by the program.

- **Flash Timing, Code 4**—When on a CO line, a station user can press the **Flash (FLASH)** button and the line will open (flash) for a period of either 2 seconds, 0.2 seconds, or 0.5 seconds depending on this assignment. (A flash can also be activated by dial code **Cnf/Trn # 4 5** or **CONF/TRNS # 4 5**.) In general, this choice reflects whether to disconnect and regain dial tone (2 seconds), or to use PBX or CENTREX features which require a flash signal (0.5 seconds). This flash timing also applies to flashes inserted when dialing via data interface units (DIUs).

NOTE:

The 0.2 seconds option is not normally used in the United States.

- **Pause After Flash, Code 5**—Some Central Offices or CENTREX facilities require a period of time after a flash signal before they can accept

dialing signals. A selection of pause timing is available to automatically delay any dialing signals after flash. This timing applies to Speed Dial calls (with flash signals between the telephone number digits) as well as to manual dialing.

- **Auto Attendant, DISA, and Call Forward External (CF-EXT.) Disconnect Timer, Code 8**—If DISA or CF EXT calls are made on loop start lines a call could lock-up (keep busy indefinitely) if the Central Office does not send a disconnect signal (CPC or AR) when the callers hang up. This timer will prevent loop start lines from locking up by disconnecting the call automatically when the timer expires, 4, 10, or 20 minutes from the start of the call. Callers will hear a warning tone and can reset the timer repeatedly by dialing "0". This disconnect feature is only needed for loop start lines.

This page intentionally left blank.

- **RRCS Seize Time, Code 8**—One channel of the RRCS Dual-tone Multi-frequency (DTMF) receiver/decoder is seized when it is needed for the decoding process, such as with a standard telephone with a DTMF dialpad. When placing outgoing calls with DTMF standard telephones, the talk path to the outside party is not “cut-through” until the RRCS circuit is released. The release time of the RRCS channel can be programmed for a time between one and nine seconds (initialized timing is four seconds)—this is the time it takes to release the RRCS circuit after the last digit is dialed. The choice of timing is a trade-off between CO line time to connect and user speed. If the time is too long, the outside called party may answer before the voice path is “cut-through,” and the caller will not be heard. If the time is too short, a standard telephone user inputting DTMF tones could be cut off prematurely from using other features, such as Speed Dial. Standard telephones will also be able to defeat Toll Restriction if the seize time is too short and they are not required to dial outgoing calls via Least Cost Routing (LCR). It is recommended that standard telephones always be required to dial outgoing calls via LCR to prevent them from defeating Toll Restriction.

NOTE:

If no digits are dialed after accessing an outgoing CO line, the RRCS remains seized for 15 seconds and then drops; however, the line remains connected.

Program 13—Defining the Message Center: Each digital and electronic telephone can receive a maximum of four message waiting indications. One of these four is reserved for the designated Message Center. Typically, a telephone (digital or electronic) accompanying a DSS console (DDSS or HDSS) will be the Message Center. However, if incoming traffic to a DDSS or HDSS console attendant is heavy, another station may be assigned to be the Message Center. If assigning the Message Center to a voice mail device, the lowest port of the customer's voice mail device should be the Message Center. (See Program 31 for voice mail group port assignments.) Initialized data assigns no port as the Message Center.

Program 15—Assigning DP/DTMF, Tenant Service to Individual Lines: (All LEDs are initialized as OFF.)

- **Automatic Release (AR) on Voice Mail or Voice Calls, Code 0**—On loop start CO lines, some Central Offices will send the AR signal—a 95 or 450-millisecond open of the CO line loop—after an external party hangs up (typically 1 ~ 15 seconds) to disconnect a loop start line. If the Central Office sends this signal after an external party

hangs up and before the VM/auto attendant transfers a call, D tone will be sent to the voice mail port (Program 30, LED 15), releasing and clearing that port for another call. This feature is active on all voice calls. The LCD of a station which is disconnected from a CO line call by the AR signal will display, “CO LINE HANG UP”. The line can be disconnected anytime by the AR signal during the “talk state” of a call. CO line calls disconnected by the AR signal will be represented on the Station Message Detail Recording (SMDR) report by a “*” next to the CO line number. Code 0 does not apply to ground start lines, which automatically disconnect when the external party hangs up.

IMPORTANT NOTE!

This option cannot always be utilized because some Central Offices may send unreliable AR signaling or no AR signaling for loop start lines. AR signaling is sometimes referred to as Calling Party Control or Loop Supervision.

- **CO Outgoing Signal, Code 1**—Each line can be independently assigned to have either Dial Pulse (DP) or Dual-tone Multi-frequency (DTMF) signaling.

NOTES:

1. *If a line is set for DP operation, the Tone Dial Select (TONE) button must be programmed on stations that must send DTMF tones over the lines.*
2. *If TIE or DID lines are programmed for dial pulse, turn LED 11 ON in Program 30 for each station port assigned to the DID or TIE line.*

- **Line Pulse (DP) Rate, Code 2**—If a line is assigned DP signaling, the rate can be either 20 or 10 pulses per second. Some Central Offices do not reliably accept 20 pulses per second.
- **Automatic Release (AR) From Hold/Transfer, Code 3**—On loop start CO lines, some Central Offices will send the AR signal—a 95 or 450-millisecond open of the CO line loop—after (typically 1 ~ 15 seconds) an external party hangs up. If the system CO line is on hold (or being transferred to another station or Auto Attendant port) when this signal occurs, it will be automatically disconnected if this option is activated. Two-CO line DISA calls always release when AR is sent. DISA release via AR is not related to this program. CO line calls disconnected by the AR signal will be represented on the Station Message Detail Recording (SMDR) report by a “*” next to the CO line number. Code 3 does not apply to ground start lines, which automatically disconnect when the external party hangs up.

IMPORTANT NOTE!

This option can not always be utilized because some Central Offices may send unreliable AR signaling or no AR signaling for loop start lines. AR signaling is sometimes referred to as Calling Party Control or Loop Supervision.

- **Automatic Release (AR) Time, Code 4**—AR signaling timing is different depending on the Central Office equipment. An assignment choice exists between Crossbar or ESS Central Offices.
- **Tandem Line Connection, Code 5**—Once a Two-line Conference call is made by an electronic or digital telephone user, the user may drop out of the conference and leave the two lines connected. The choice exists for each line that may have this capability. This option must be enabled to allow trunks to be used for outgoing DISA calls.
- **Forced Account Code (Verified or Non-verified), Code 7**—If the Forced Account Code feature is used (see Program 30) a station user is required to enter an Account Code before a CO line call can be completed. A choice exists for each line.
- **Operation After CO Line Flash, Code 8**—If a standard telephone user is on an existing CO line call and flashes the hookswitch on their telephone, a Dual-tone Multi-frequency (DTMF) receiver channel may or may not be connected, depending on this assignment. If the trunk is a rotary dial only type, the CRCU2 must be seized after flash when dialing from DTMF standard telephones. The CRCU2 will decode the dialed tones and send dial pulses to the line.

Program *15—Tenant Line Assignments: A system can be shared by more than one tenant (business). This program assigns lines to the tenants. The RCTUC/RCTUD Common Control Unit can support up to four tenants, and the RCTUA and RCTUB units can support two. Initialized data assigns all lines to Tenant 1.

Program 16—Assigning Line Groups: Lines may be accessed with a dialing code instead of with a CO line button. With DK280 systems operating with an RCTUC/RCTUD Common Control Unit, up to 16 groups may be accessed by dialing 801 ~ 816 (eight groups with the RCTUA or RCTUB Common Control Unit). This is useful for WATS lines or other facilities, and is heavily used in Least Cost Routing and Pooled Line Button assignments. A general group for outside calling is available with a "dial 9" access code, which is the initialized state for all lines. Program 16 is used to assign each line to one of these groups. Do not attempt to assign a line to more than one group. A line need not be assigned to

a group. If lines are not used, they should be taken out of all groups, including the "dial 9" group. Automatic Busy Redial (ABR) will not function if unconnected lines are assigned to a line group.

Program 17—TIE/DID Line Assignments: Program 17 assigns lines for TIE and DID operation:

- **Page/Handsfree Answerback, LED 01**—The External Page and Handsfree Answerback features can be optionally activated for each TIE line. This option does not apply to DID lines. FCC regulation does not allow page or voice announce on DID line calls.
- **Wink/Immediate, LED 02**—Select Wink Start or Immediate Start for the entered TIE or DID line. This option applies to REMU, PEMU, and RDDU TIE/DID lines. See Program *41-2 for RDTU TIE/DID wink/immediate start assignments.
- **DID Camp-on/Busy, LED 03**—Turn LED 03 on if DID callers should hear ringback tone and camp on to busy stations when calling busy stations. Turn the LED off if the DID callers should hear busy tone when calling busy stations. It is recommended to turn LED 03 ON for all DID lines.
- **DID/TIE Second Dial tone Option, LED 04**—If the second dial tone option is selected (LED 04 off), callers calling in on DID or TIE lines will hear a tone after dialing the access codes of those lines (the office code of DID lines; the TIE line access code for TIE lines). The tone will not be sent to callers if this option is not selected (LED 04 on).

IMPORTANT NOTE:

Normally, TIE lines require a second dial tone (LED 04 OFF) and DID lines should not return a second dial tone (LED 04 ON). The initialized data is set for DID lines so this data must be changed when installing TIE lines.

Program *17—DID Intercept Port Number: DID calls in which callers have dialed a vacant or invalid port can be routed to intercept ports assigned with this program. Each DID line can have its own intercept port.

Program 19—Alternate Background Music (BGM) Source Slot Assignment: The printed circuit board (PCB) connected to the alternate BGM source can be in any slot. Use this program to designate that slot. If the source will be connected to a PEKU or PESU, run LED 9 or LED 10 in Program 10-2 to tell the system whether the PEKU or PESU will support the source. LEDs 09 and 10 in Program 10-2 should be OFF if the source will be connected to a PSTU, RSTU, or RDSU. (Only Circuit 2 of these PCBs can support the BGM source.) The alternate BGM source sends BGM to the external speakers

and telephone (digital and electronic) speakers. If an alternate BGM source is utilized, the Music-on-Hold (MOH) source connected to the Common Control Unit (RCTUA, RCTUB, RCTUC/RCTUD) will continue to play for lines and stations that are on hold.

IMPORTANT NOTE!

If the alternate BGM source is not connected to a PEKU, PESU or PSTU, RSTU, or RDSU, assign Slot 11 as data in Program 19. This will ensure that all PSTU or RSTU ports function normally. Digital telephones or electronic telephones installed in Slot 11 will not be affected by this assignment.

Program 20—Data Interface Unit (DIU: PDIU-DI and PDIU-DS) Configuration: This program identifies the PDKU station ports connected to DIUs and the type of DIU connected.

NOTES:

1. *DIUs can be connected to ports associated with PDKU1 Circuits 1 ~ 7 only. All PDKU2 Circuits, 1 ~ 8, can support DIUs. RDSU digital Circuits 5 ~ 8 can support DIUs.*
2. *See Chapter 5 of the Installation Section, 100-280-205, to identify which slots can support DIUs.*

- **DIU Connection, LED 01**—Light this LED if there is an Integrated Data Interface Unit (PDIU-DI) or a Stand-alone Data Interface Unit (PDIU-DS) connected to the digital port. Each PDIU-DI uses the same digital port as the telephone it is attached to. Each PDIU-DS requires a separate digital port.
- **AT Commands and Result Codes, LED 02**—If the DIU must respond to AT commands and return result codes, this LED should be lit. DIU "AT" dialing commands and "result" codes are listed in the Data Interface User Guide in the Operating Procedures section of this manual. If LED 02 is not lit, the DIU will only respond to AT dialing commands (ATDT, ATD, and ATDD) and will not return result codes. If the DIU is connected to a terminal or a personal computer with communication software, LED 02 should be ON. If the DIU is connected to a modem, LED 02 should be ON. If the DIU is connected to a printer, LED 02 should be OFF.
- **PDIU-DS to Modem Connection, LED 03**—If a PDIU-DS is connected to the digital port, identify whether the PDIU-DS is connected to a modem (LED ON) or not connected to a modem (LED OFF). If not connected to a modem (LED OFF), the connected device can be a DCE or DTE. This option is not necessary for PDIU-DIs, because they are not normally connected to modems.

- **PDIU-DI or PDIU-DS Connection, LED 04**—Light this LED if a PDIU-DS is connected to the digital port; leave OFF, if a PDIU-DI is connected. If a PDIU-DI is connected, the digital telephone supporting it may require the **Data Call (DATA)**, **Data Release (DRLS)**, and/or **Modem (MODEM)** buttons assigned in Program 39.

- **Auto Pause Behind PBX, LED 05**—If the system CO lines are connected to a PBX, CENTREX, or a Central Office that is slow to return dial tone after seizure, light this LED to insert a pause before and after the PBX or CENTREX access code is dialed by the DIU. Also, light LED 05 to automatically insert a pause before network telephone numbers are autodialed by DIUs.

NOTE:

The pause length is set in Program 12-3, and lines behind PBX/CENTREX are assigned in Programs 42-0 and 42-1 ~ 8.

- **DTR Pulse, LED 06**—If a PDIU-DS is connected to a modem, turn LED 06 ON to cause the modem to disconnect the CO line when the user presses the **Data Release (DRLS)** button. The PDIU-DS will pulse DTR on outgoing modem calls only, not on incoming modem calls. Initially, the modem should be sent AT command "AT & D2" so it can recognize DTR pulse sent to it from the PDIU-DS.

NOTE:

It is recommended to change the escape sequence (typically + + +) of all PDIU-DIs that call the modem pool. Separate sequences will enable users to escape and issue AT commands to either modem or PDIU-DI independently. Escape sequences are changed with the AT\$2 = __ command.

- **Data Security Groups, LEDs 17 ~ 20**—Data security groups can be set to block data calls between DIUs. DIUs can only make data calls to DIUs in the same security group. LEDs 17 ~ 20 assign the DIU to the appropriate security group: light LED 17 for Group 1; LED 18, for Group 3; LED 19, for Group 2; and LED 20, for Group 4.

Typical LED settings for Program 20.

- **PDIU-DI Connected to a Terminal or Personal Computer**—LEDs 01, 02, 05, and 17 ON; all other LEDs OFF.
- **PDIU-DS Connected to a Printer**—LEDs 01, 04, and 17 ON; all other LEDs OFF.
- **PDIU-DS Connected to a Modem**—LEDs 01, 02, 03, 04, 06, and 17 ON; all other LEDs OFF.

Program 21—Modem Pool Port Assignments: With this program, identify modems connected to standard telephone ports (line side of modem) and digital/PDIU-DS ports (RS-232 side of modem). Each selection pair assigns the modem to the system modem pool. With data security groups (Program 20, LEDs 17 ~ 20) and the call blocking feature (Program 31, LED 04), modem access can be denied or allowed to data users.

NOTES:

1. When modems are connected to standard telephone ports (PSTU, RSTU, PESU, RDSU/RSTS) the Executive/Privacy Override blocking feature (Program 31, LED 18) should be enabled for the modem RSTU, PSTU, PESU, and RDSU ports for data security. The LED 18 feature should be disabled to enable callers to switch from voice to data, or vice versa.
2. Digital telephones with PDIU-DIs that must access modems from a pool require a Modem (MODEM) button assigned in Program 39.
3. PDIU-DS ports that are connected to modems in the modem pool should be set with LEDs 01, 02, 03, 04, and 06 ON in Program 20.
4. If a modem connected to PDIU-DS is connected to a telephone network line instead of a standard telephone station port, Program 21 should not be used.
5. Use Program 22 to assign modem/PDIU-DS stations to hunt sequences
6. DIUs can be connected to ports associated with PDKU1 Circuits 1 ~ 7 only. All PDKU2 circuits, 1 ~ 8, can support DIUs. RDSU Circuits 5 ~ 8 can support DIUs.

Program 22—Data Interface Unit (DIU) Station

Hunting: If a DIU station (printer, modem, etc.) is busy, data station hunting allows the data call to that station to hunt to an alternate DIU station assigned in this program. If the hunted DIU station is busy, the system will ring the next "hunt-to" station, and so on. If all DIU stations in the "hunt-to" sequence are busy, then the data caller will receive a busy tone. It is recommended that all PDIU-DS station ports grouped in a modem pooling or printer pooling/server configuration be placed into a hunt-sequence arrangement with Program 22. Program 22 applies to PDIU-DS and PDIU-DI data stations, not telephone stations.

NOTE:

When a PDIU-DS is connected to a modem(s) assigned to the system modem pool in Program

21, modem hunting is automatic when the user presses the Data Call (DATA) button to transfer a line call to a modem; however, if the user dials the modem's PDIU-DS's station number, modem hunting will follow the hunt sequence specified in Program 22.

Programs 23 and 24—Built-in Auto Attendant Announcement Device Assignments:

Assign customer-supplied Auto Attendant announcement devices (digital announcers) to standard telephone ports (RSTU, PSTU, PESU, RDSU/RSTS) with these programs. Devices which will deliver primary announcements—dialing options and greeting heard when callers first call in—should be assigned in **Program 23**, and devices which will deliver secondary announcements—typically options offered to unanswered calls routed back to the Auto Attendant—should be assigned in **Program 24**. As many as eight devices can be connected to a system, a maximum of four for primary announcements and a maximum of four for secondary announcements (see Note).

NOTES:

1. Any combination is allowed within the maximum limitations. For example, three primary announcements and one secondary announcement are allowed.
2. Ports assigned in Programs 23 and 24 should never be assigned with External Auto Attendant voice mail options in other programs (30, 31, 81 ~ 89, etc.)

Program 25-1—Built-in Auto Attendant Call Overflow

Time: This program sets the time it takes an unanswered incoming Auto Attendant call to overflow to a preassigned station or stations. The time can be anywhere from 12 to 24 seconds—the default is 20 seconds. The overflow station or group of stations is assigned in Programs 81 ~ 89.

NOTE:

Auto Attendant will not answer when all of the RRCS circuits and primary announcements are busy.

Program 26—Built-in Auto Attendant Camp-on Busy

Time: This program establishes the time it takes for unanswered Auto Attendant calls camped on to busy stations to be routed to other destinations. The time—which is set for the "camped-on to station"—can be set anywhere from 011 seconds to 0999 seconds, and the default is 16 seconds. (Ring/No Answer call time to idle stations is fixed at 16 seconds unless Call Forward/No Answer is set at the called station.) The destination that the call can be rerouted to depends on the Auto Attendant application. In Auto Attendant applications that use just pri-

mary announcement devices, the destination is set in Program 10-3, and can be either back to the primary announcement or the normal ringing pattern of the line that the call came in on (Programs 81, 84, or 87—also see Program 10-3, LEDs 15 and 16 for disconnect time options). In applications that utilize secondary announcement devices in addition to primary ones, the rerouted calls will automatically be sent to secondary devices.

Program 27—Digital Telephone Handset/Headset Volume Level: This program sets the initial off-hook volume level for each digital telephone handset and/or headset. This level can be changed with the digital telephone's volume control button while the handset or headset is off-hook, but it will return to the default level set in this program after the handset is placed on-hook. The volume level range for digital telephone handsets is 0 ~ 8, with 0 as the lowest volume. Anytime a handset is off-hook, the station user can adjust the volume level anywhere between 0 ~ 8. The level setting established in this program, however, can only be from 1 ~ 4.

Program 28—DSS Console (DDSS and HDSS)/Attendant Telephone Assignments: Up to eight DDSS consoles, or eight HDSS consoles, or any combination of the two types of consoles up to eight may be installed with an RCTUC/RCTUD Common Control Unit. (The RCTUA can support three DSS Consoles, and the RCTUB can support four.) A DDSS console can only be connected to Circuit 8 of a PDKU, and an HDSS console can only be connected to Circuits 7 and 8 of a PEKU. The telephone connected to Circuit 1 of the PCB supporting a console is designated as an Attendant telephone. Consoles and telephones are numbered 1 ~ 8 as they are installed from the lowest to highest slot number. For example, if a PDKU in Slot 11 had a DDSS console connected to it, the DDSS console would be designated Console #1 and the digital telephone connected to Circuit 1 would be Attendant Telephone #1. As many as four consoles can be assigned to one attendant telephone. Because more than one console can be assigned to an attendant telephone, the detailed arrangement must be programmed. Initialized data assigns one console to one attendant telephone, both connected to the same PDKU or PEKU PCB.

Program 29—DSS (DDSS and HDSS) Console Button Assignments: Each button on the DSS consoles may be flexibly assigned as either a **Direct Station Selection (DSS)**, **Line (CO)**, or **SD** button. The standard equipped **Night Transfer (NT)**, and **All Call Page (AC)** buttons may be changed to one of these three types, but not

vice versa. Station Speed Dial buttons assigned to a DSS console share the associated attendant digital or electronic telephone's Speed Dial memory. The personal Speed Dial numbers of the DSS console circuit port(s) are not available. Initialized data assigns the 60 buttons to be **Direct Station Selection (DSS)** 200 ~ 257, **All Call Page (AC)**, and **Night Transfer (NT)**. Each of the consoles can be independently programmed.

Program *29—Add-on Module (ADM) Button Assignments: This program allows ADM buttons to be customized. Each ADM button can be programmed as either a Direct Station Selection, CO line, or System and Personal Speed Dial buttons. 2000-series Digital Telephones only can connect with ADMs, and up to two ADMs can be connected to a telephone. The initialized button assignments are DSS 200 ~ 219 for ADM1 and DSS 220 ~ 239 for ADM 2. The RCTUC/RCTUD Common Control Unit can support up to 120 ADMs; The RCTUB up to 40; and the RCTUA up to 12.

IMPORTANT NOTE

This Program must be entered for each port assigned an ADM or the ADM will not function.

Program 30—Station Class of Service:

- **Privacy Override, LED 19**—Privacy Override allows a station to enter into and overhear an existing CO line conversation by pressing a common CO line button. A maximum of two stations may override an existing "station-line" conversation. A warning tone may be set optionally (see Program 10-2). The choice with LED 19 is for which station is allowed to override calls with Privacy Override. Privacy Override of Direct Inward System Access (DISA) two-CO line calls is not allowed.

NOTES:

1. To configure the DK280 system to operate as nonprivate, allow Privacy Override from all stations.
2. Privacy Override can be blocked by a station via a Privacy button (Program 39) or by the Executive/Privacy Override blocking option (Program 31, LED 18).
3. See Table 2-C at the end of this chapter.

- **Executive Override, LED 18**—Executive Override allows a station to break into and overhear an existing station conversation by dialing the digit 3 after the busy station number. A warning tone may be set optionally (see Program 10-2). The LED 18 option is for which calling station can use Executive Override.

PROGRAMMING PROCEDURES — INSTRUCTIONS

SECTION 100-280-302

NOTE:

Executive Override can be blocked by stations that have Executive/Privacy Override blocking enabled in Program 31, LED 18; the Privacy on Line (PRIVACY) button does not block Executive Override. See Table 2-C at the end of this chapter.

- **DND Override, LED 17**—An electronic or digital telephone can have a button programmed for Do Not Disturb (DND). When called, a station with DND activated will return very fast busy tone (four tones per second). If the caller dials "2" after dialing the station number, a DND Override tone will be heard on the called station's speaker. The LED 17 assignment is for which calling station can use DND Override.
- **Toll Restriction Traveling Class Code Change, LED 16**—If this LED is lit for a port, the station occupying it can change the four-digit Toll Restriction Traveling Class of Service Codes established in Program 44B. Stations selected for this feature must follow the dialing sequences below to change the codes:
 - Class 1: Intercom (INT) + # 6 9 1 + the 4-digit code + Redial (REDIAL)**
 - Class 2: Intercom (INT) + # 6 9 2 + the 4-digit code + Redial (REDIAL)**
 - Class 3: Intercom (INT) + # 6 9 3 + the 4-digit code + Redial (REDIAL)**
 - Class 4: Intercom (INT) + # 6 9 4 + the 4-digit code + Redial (REDIAL)**
 - Class 5: Intercom (INT) + # 6 9 5 + the 4-digit code + Redial (REDIAL)**
 - Class 6: Intercom (INT) + # 6 9 6 + the 4-digit code + Redial (REDIAL)**
 - Class 7: Intercom (INT) + # 6 9 7 + the 4-digit code + Redial (REDIAL)**
 - Class 8: Intercom (INT) + # 6 9 8 + the 4-digit code + Redial (REDIAL)**

NOTE:

Electronic telephones that do not have the REDIAL button, can use the the # button instead.

- **Verified Account Code Change, LED 15**—If selected for this feature, a station can change the Verified Account Codes established in Program 69. Selected stations must dial the the following sequence to change the codes:
 - Intercom (INT) + # 6 5 9 + 0 0 0 ~ 2 9 9 + Verified Account Code + Redial (REDIAL)**

NOTE:

Electronic telephones that do not have the REDIAL button, can use the the # button instead.

- **Verified Account Code, LED 14**—If this feature is selected, all Account Codes (Forced or Voluntary) dialed by the station user (or DISA line user) will be verified per Account Codes set in Program 69. If the station user fails to dial one of these specific Verified Account Codes, the call cannot be executed (Forced), or the Account Code will not be validated for the SMDR call report (Voluntary).
- **Dial Pulse (Dual-tone Multi-frequency (DTMF) Off), LED 11**—If any device, DID, or TIE line station port does not require the RRCS for DTMF decoding, it should be programmed for Dial Pulse (LED 11, ON). When the device goes off-hook or the DID or TIE line is seized for an incoming call, the RRCS will not be accessed, thereby reducing potential traffic to the RRCS.
- **Change DISA Security Code, LED 10**—This allows a selected station to change the DISA security code by dialing **Intercom (INT) + # 6 5 8**.
- **Change TR Override Code, LED 09**—Two Toll Restriction Override codes are available in the system. When one of these codes is dialed from any station, all Toll Restriction is bypassed. These codes can be changed only by stations assigned in this program by dialing **Intercom (INT) + # 6 5 4** for Code 1, or by dialing **Intercom (INT) + # 6 5 5** for Code 2.
- **Forced Account Code, LED 08**—If this feature is selected, a station or Direct Inward System Access (DISA) CO line user using a line with a Forced Account requirement (Program 15-7) must enter an Account Code before the call can be completed. If Forced Account Codes should be verified, turn on LED 14 in Program 30. The digit length of Forced Account Codes is determined in Program 60-4.
- **Off-hook Call Announce (OCA) Automatic, LED 07**—A busy digital or electronic telephone can receive a second voice communication on intercom via Handsfree Answerback if the OCA feature is installed. If a calling station does not have the automatic function, the user must dial an extra digit of 2 after hearing busy tone in order to gain access to OCA. Initialized data makes all stations automatic for OCA.
- **Automatic Busy Redial (ABR) Access, LED 06**—The ABR feature can be enabled or denied for each station. The system will select the last line in the originating line group each time ABR is initiated (also see Program 10-1). If the ABR access feature is not enabled here, the "ABR" Soft Key will not appear on LCD telephones.

NOTE:

ABR overrides Program 41. Program 41 is normally used with Least Cost Routing (LCR).

- **Speed Dial, LED 05**—A station may be denied the use of Speed Dial (Station and System) with this program. Initialized data allows Speed Dial for every port.
- **Microphone Button On at Start of Call, LED 03**—The microphone, as well as the Mic (MIC) button LED, can be selected to be on or off at the start of a call if the Push On/Push Off mode (see Mic (MIC) Button Lock, LED 02) is chosen.

NOTE:

When receiving intercom calls, the flexible Microphone Cut-off (MCO) button (Program 39) can control the microphone to prevent room monitoring and Handsfree Answerback.

- **Mic (MIC) Button Lock, LED 02**—An electronic or digital telephone microphone can be turned on or off by using the Mic (MIC) button. Two modes of operation are available. A momentary operation requires that the Mic (MIC) button be continuously pressed to disable the microphone. A Button Lock operation allows an alternate action Push On/Push Off of the Mic (MIC) button. LED 02 should be ON if microphone lock operation is desired.
- **Speakerphone Enabled, LED 01**—Any electronic or digital full speakerphone operation can be disabled by assignment with this program. If disabled, a speakerphone will act as a handsfree electronic or digital telephone. Initialized data enables all speakerphones.

Program *30—Group Page Assignments: Digital and electronic telephones can be assigned to intercom page groups with this program. Each group can have as many as 120 stations. The RCTUC/RCTUD Common Control Unit can support as many as eight groups, and the RCTUB and the RCTUA units can support up to four. Telephones can be a member of more than one group. Station users can access each group separately by dialing access codes. (See Program 05 for access codes.)

Program 31—Station Class of Service: This program sets most voice mail (VM) or External Auto Attendant port assignments. Each standard telephone port (RSTU, PSTU, PESU, RDSU) connected to a Toshiba VP (or INTOUCH) voice mail system should have LEDs 04, 05, 09, 15, 16, 17, 18, 19, and 20 turned ON. These LED's should be set ON for VM ports only, not for telephone ports.

NOTES:

1. LED 04 may be ON or OFF, depending on VM device operation. See the LED 04 write up that follows.
2. Initialized data reads LED 10 for all ports
3. If LED 15 or 19 is lit, LED 17 must be lit. If LED 20 is lit, LEDs 17 and 19 must be lit.

IMPORTANT NOTE:

Do not assign Program 31 VM/AA options to built-in Auto Attendant digital announcer ports.

- **Toshiba VP (B + Station Number), LED 20**—This feature is designed for Toshiba VP (or INTOUCH with B.06 and higher software) systems connected to a standard telephone port (PSTU, RSTU, PESU, RDSU). DTMF B tone followed by the station number is sent to Toshiba VP (or INTOUCH) in situations in which Toshiba VP (or INTOUCH) would not normally know the location from which a call was coming, such as hold recall or "blind" ring transfer recall. This allows Toshiba VP (or INTOUCH) to respond more intelligently with appropriate voice prompts. LED 20 should be lit for standard telephone ports connected to voice mail devices only, not for station ports connected to telephones. The station number is not returned, it blind transfers to a DND station.

NOTE:

Toshiba VP (B No Station) must be enabled with LED 19 to allow this function.

- **Toshiba VP (B No Station), LED 19**—DTMF "B" tone is sent to Toshiba VP (or INTOUCH with B.06 and higher software) to signify a recall where Toshiba VP (or INTOUCH) already knows the recalling station number. Again, this allows Toshiba VP (or INTOUCH) to respond more intelligently with appropriate voice prompts. This LED should be lit for standard telephone ports (RSTU, PSTU, PESU, RDSU) connected to voice mail devices only, not for station ports connected to telephones.
- **Executive and Privacy Override Blocking (Modem), LED 18**—This feature denies a station user the capability to break in with Privacy or Executive Override to a called station's connection. It should be set for standard telephone ports (RSTU, PSTU, PESU, RDSU) connected to a modem or voice mail/auto attendant device in order to ensure data and voice security. This feature may also be used to deny override of any station.

NOTES:

1. The Privacy Release (PRV RLS) button may be used to disable Privacy on a call-by-call basis; this button cannot disable Executive Override blocking.
2. If a modem is assigned to the system modem pool in Program 21, use this option to provide data security (LED 18 ON for modem standard telephone ports assigned in Program 21).
3. If using the system modem pool for data calls that must be switched between voice

PROGRAMMING PROCEDURES — INSTRUCTIONS

SECTION 100-280-302

and data, LED 18 in Program 31 should be OFF for the modem standard telephone ports assigned in Program 21.

- **End/End Signal RCV (VM), LED 17**—Activation of this option allows End-to-End Signaling of Dual-tone Multi-frequency (DTMF) tones through the system. It is required on all voice mail ports (RSTU, RDSU/RSTS, PSTU, PESU, RDSU) for proper signaling communication.
- **Receive Voice Mail (VM) ID Code, LED 16**—When a station is call forwarded to a VM system, certain identification (ID) Dual-tone Multi-frequency (DTMF) tones will automatically be sent to direct the call to a specific mailbox (VM ID Code #656). The automatic ID is also sent to the VM device when electronic or digital telephone users retrieve messages via the Intercom and Message Waiting buttons (VM ID Code #657). The VM port must be programmed for this feature to allow the reception of DTMF digits.
- **Toshiba VP Integration (A Tone/D Tone), LED 15**—This option will cause an answer tone (DTMF A tone) to be automatically sent to Toshiba VP (or INTOUCH) when a station answers, and a disconnect tone (DTMF D tone) when a station disconnects. This allows Toshiba VP (or INTOUCH) to respond quickly rather than waiting a long time in time-out situations. If the Central Office (CO) provides an Automatic Release (AR) signal, D tone is also sent to disconnect voice mail (VM) ports when outside callers hang up (see Program 15-0 and 15-3).

NOTE:

AR signaling is sometimes referred to as Calling Party Control or Loop Supervision.

- **Pooled Line Button Operation, Program 31—No Flash if No Ring, LED 12**—If LED 12 is on for a station port, incoming line calls in pooled line groups will only flash on pooled line buttons if the line is also assigned to ring that station in Program 81-89. This option is available with DK280 Release 2 software and above — RCTUB2 and RCTU C/D2, not RCTUA, RCTUB, or RCTU C/D.
- **All Call Page Allowed-Digital and Electronic Telephones, LED 10**—Any station may be allowed to receive an All Call page. This does not alter the station's ability to initiate an All Call Page. A maximum of 120 stations may be paged at one time. See Program *30 for station page group assignments.
- **Voice Mail (VM) No Conference, LED 09**—If activated, a station is prohibited from having any Conference calls. It should be used for VM (RSTU, PSTU, PESU, RDSU/RSTS) ports to prevent undesirable Conference calls.
- **Voice Mail (VM) Groups 1 ~ 4, LED 05 ~ 08**—The system allows up to four VM station port groups to be configured for support of up to four

VM/auto attendant devices. One group is intended for each different machine. All standard telephone ports (RSTU, PSTU, PESU, RDSU/RSTS) connected to a particular VM machine should be assigned to the same VM group. The purpose of the VM grouping is to allow efficient use of the message waiting (MW) set and cancel operations from the VM machine. Since each digital and electronic telephone can only have a maximum of four messages waiting, the VM device should set MW only once, regardless of how many messages there are.

- **Voice Mail (VM) to VM Call Blocking, LED 04**—This prevents VM/auto attendant ports from call forwarding to other VM ports during screened or supervised voice mail transfers. If auto attendant calls are screened or supervised, this LED should be ON for all VM/auto attendant ports; if VM/auto attendant calls are ring (blind) transferred, this LED should be OFF for all VM/auto attendant ports.
- **Off-hook Call Announce (OCA) Enabled (Receive), LED 03**—Any digital or electronic telephone equipped for OCA should be assigned this option to receive OCA. This program does not affect the station's ability to originate OCA. See Chapter 2 in the Installation Section, 100-280-202, to identify which slots can support OCA.
- **Handsfree No Warning, LED 02**—Normally, a 1-second warning tone is sent to a handsfree digital or electronic telephone to inform its user that someone is calling and that they can be heard. If the warning tone is not desired at the called digital or electronic telephone, this assignment can disable it. This will also prevent ringing the digital or electronic telephone as a ring-first situation, allowing silent room monitoring of the area surrounding the telephone. Initialized data activates the warning tone for all ports.
- **Handsfree Disabled, LED 01**—It is possible to disable the intercom handsfree function on any digital or electronic telephone.

Program *31—Group Pickup Assignments: Stations can be divided into as many as 20 pickup groups. Station users can pick up calls that are ringing any station within their group by dialing a single access code (or with a Pickup button assigned with Code 480 in Program 39), and pick up calls that are ringing stations in other groups by dialing selected access codes. Stations can belong to more than one group. (See Program 05 for access codes.)

Program 32—Automatic Preference: Automatic Preference for digital or electronic telephones (see Note 2) via handset off-hook or the Speaker button is the automatic connection to lines or the intercom under various conditions. With Ringing Line Preference, a digital or electronic telephone user by going off-hook (or by pressing the Speaker button) may be automatically connected to the lowest line ringing in without having to press a CO line button or dial an access code. If no lines are ringing and an electronic or digital telephone goes off-hook, the

station can be automatically connected to the intercom or to a line. The line connected can be the lowest numbered line available on the telephone or the highest idle line from a selected group.

NOTES:

1. *The programming digital or electronic telephone at Port 05 is set to auto select an intercom line any time system power is turned OFF, then ON.*
2. *This program does not apply to standard telephones. To allow system features to be accessed, standard telephones always receive system intercom dial tone when originating calls.*
3. *Initialized data assigns Ringing Code 1 and Automatic Off-hook Code 00 for all ports.*

Program *32—SMDI Voice Mail Message Center:

When using SMDI voice mail integration, the Voice Mail Port Message Center must be assigned for each station. The voice mail port assigned will be called when the station user presses the telephone MSG button after the MSG LED has been set (flashing) by the voice mail machine. The SMDI port is normally the first voice mail standard telephone port in the voice mail hunt group. It is normally the same port for all stations.

Program 33—Station Hunting (Voice Calls Only): If a station is busy, Station Hunting allows the ringing of an alternate station as defined by the assignments in this program. If the "hunt-to" station is busy, the system will try to ring the next "hunt-to" station, and so on. If a "hunt-to" station is in the Call Forward mode, the call forward will have priority over the hunt. A line will hunt from a station only if it has been assigned to ring at that station exclusively (see Programs 81 ~ 89). Initialized data does not assign "hunt-to" points for any station.

Program 34—Hold Recall/ParkTiming: Each station can have a different time (from 011 to 160 seconds) from the point of placing a call on hold or park to the point of recall. Initialized data assigns a recall time of 032 seconds to all ports.

Program 35—Station Class of Service:

- **Busy Station Transfer with LED 20 and Busy Station Ringing with LED 19—**Busy Station Transfer (BST) and Busy Station Ringing (BSR) operate together to ensure that a busy digital or electronic telephone station always receives transferred line calls along with LED and tone indications. The station or Voice Mail (VM)/auto attendant device that transfers the call must be programmed with BST (LED 20 ON) and the one that receives it must have BSR (LED 19). When a busy station with BSR receives a transfer from a station or VM/auto attendant with BST, there will be a muted repetitive tone (1 second ON, 3 seconds OFF) at the busy station and the intercom LED will flash at the ringing rate until the

station transferring the call hangs up. When it does hang up, the line call will then camp-on to the busy station. The busy station will be alerted of the camp-on by a camp-on tone (five quick tone bursts), the CO line LED will flash at the exclusive hold rate, and a message ("CAMP-ON X", X = the line number) will appear on the LCD (if equipped). Among other applications, one in which a VM/auto attendant device that transfers calls to a typically busy answering position station will benefit from this feature—some auto attendant devices cannot transfer a call to a busy station if BST and BSR are not activated.

NOTES:

1. *A BST station will receive ringback tone, instead of busy tone, when transferring a call to a busy BSR station.*
2. *Do not assign BST / BSR to built-in Auto Attendant announcement ports.*

- **Automatic Hold, LED 18—**If this feature is allowed, station users with CO line buttons can place a CO line or intercom call on hold, then call another line or station just by pressing another CO line button or the **Intercom (INT)** button and dialing the number. If Automatic Hold is not allowed, users can put calls on hold and place calls, but they will have to press the **Hold (HOLD)** button before accessing another line or the intercom.

NOTES:

1. *CO line or intercom calls that appear on the intercom button will automatically hold when accessing another line.*
2. *It is recommended that the Release Call (RLS) button be provided via Program 39 to telephones programmed for Auto Hold.*

- **Continuous DTMF Tones Off, LED 17—**2000-series Digital Telephones can send DTMF tones for as long as station users press their buttons (80 msec. minimum). This feature can be disabled with LED 17. If it is disabled, DTMF tones sent by these telephones will be either 80 or 160 milliseconds depending on the selection made with Program 10-1, LED 04 and Program 10-2, LED 06.

NOTE:

PKU1 does not support continuous DTMF tones on 2000-series digital telephones.

- **No Call Forward/No Answer on Handsfree Answerback Calls, LED 16—**A Handsfree Answerback call to an idle station in the Call Forward No-Answer or Call Forward-Busy/No Answer mode will not forward if this feature is activated. This prevents the call from being forwarded 8-60 seconds after the called party has been talking. Outside calls and busy intercom calls to the station will continue to forward with this feature set.

NOTE:

The caller can press the "RING" Soft Key on digital telephones or dial 1 on digital or electronic telephones to activate Call Forward on Handsfree Answerback calls.

- **LCD Individual Message, LED 05**—This option allows LCD digital and electronic telephones to store up to ten personal messages and offers the option of entering alphanumeric memos for each of the LCD's Station Speed Dial numbers. As many as 96 stations (only 48 with the beta test) can have this option for systems operating with the RCTUC/RCTUD Common Control Unit (16 with the RCTUB and six with the RCTUA). This program defines which ports can have this feature. Initialized data assigns the lowest ports to have this ability. A low port must be disabled before adding a port above the initialized ports.
- **Message Waiting (RCV), LED 04**—If the message waiting indication is not desired on an electronic or digital telephone, this program can be used to deny it. This does not affect that station's ability to send a message waiting indication to another station.
- **LCD Type 32/12, LED 02**—Digital and 6500-series LCD electronic telephones have 32-character displays. Therefore, assignments should be left in the initialized state of 32 characters. LED 02 must be ON to receive the voice mail message waiting indication.
- **LCD Display, LED 01**—This option should be used (LED 01 ON) for all stations (even non-LCD), unless it is desired to disable the station's LCD and message waiting functions.

Program 36—Fixed Call Forward: Fixed Call Forwarding is different from other station Call Forwarding options. It is fixed in terms of the destination station number which is assigned in this program. The station user cannot change the Fixed Call Forward destination, unlike the other station Call Forwarding options. This feature is valuable for forwarding to voice mail (VM) devices or to an attendant. If Fixed Call Forwarding is set on a station, the station will not ring and all calls will forward immediately.

Program 37—Ring Transfer (Camp-on) Recall Time: If a busy or ringing station does not answer a call sent to it via call transfer (CO lines or over TIE lines), the station originating the transfer will be recalled after an amount of time determined with this program. This time (011 ~ 999 seconds) is set independently for each originating station station port. Initialized data sets all stations for a 032-second recall time. Ring Transfer must first be enabled for the system with Program 10-1, LED 07 ON.

Program 38—Digital and Electronic Telephone Buttonstrip Type: Four telephone button arrangements are provided (see the Program 38 System

Record Sheet). It is best to start with one of these four, and then move on to Program 39, where individual buttons may be programmed. Initialized data treats all digital telephone ports as 20-button types with 17 CO line buttons, one Intercom button, one Do Not Disturb button, and the Speed Dial button. See the System Record Sheet for electronic telephone arrangements.

Program 39—Flexible Buttonstrip Assignment: Program 38 should be run before entering Program 39. Flexible feature buttons are assigned to telephones on a button-by-button basis with Program 39. (See the System Record Sheet for details.)

Program 40—Station CO Line Access: Any station can have access to as many lines as desired. Any station denied access (either to make a call or to answer a call) to a line cannot seize that it by dialing either an access or pickup code or by using a CO line button. This also denies access via Least Cost Routing. Use this program to divide lines for Tenant Service. Use Program 40 to deny CO line call pickup. If only outgoing access is to be prevented, use Program 41.

Program 41—Station Outgoing Call Restriction: Each station (or Direct Inward System Access (DISA) CO line) can be restricted from outgoing access to each line. If so restricted, that station can still answer a ringing line or pick up a call on hold. All Call Pickup functions operate normally. This does not deny access via LCR. Automatic Busy Redial (ABR) overrides Program 41.

Program *41 Series—T1 Span Assignments: T1 parameters and assignments are made with the Program *41 series (along with the Program *42 series). The RCTUC/RCTUD Common Control Unit can support up to six RDTUs, and the the RCTUB unit can support up to two. The RCTUA cannot support the RDTU. (See T1, Section 100-280-400 for additional T1 programming information.)

■ **Program *41-1 Framing/Coding Assignments:**

- T1 Span Framing Assignments, LED 01—Each RDTU PCB can be individually assigned for Super Frame or Extended Super Frame. LED 01 should be off for Super Frame, or ON for Extended Super Frame.
- T1 Span Line Code Assignments, LED 02—Each RDTU PCB can be individually assigned for B8ZS or AMI coding. LED 02 should be on for B8ZS, or OFF for AMI.

■ **Program *41-2 T1 Channel Assignments:** RDTUs provide 8, 16, or 24 channels, each of which can operate independently as CO lines (Ground Start or Loop Start), TIE lines (Wink or Immediate Start), or DID lines (Wink or Immediate Start). Assign the number of channels for each RDTU with Program 03.

IMPORTANT NOTE

System Power must be momentarily turned OFF (5 seconds) then ON for Program *41-2 to take effect.

■ **Program *41-3, T1 Span Transmit Level PAD Assignments**—The transmission path of each RDTU can be set for one of several PAD settings:

- Enter 1 for +6 decibel (db) padding
- Enter 2 for +3 db
- Enter 3 for 0 db
- Enter 4 for -3 db
- Enter 5 for -6 db (initialized setting)
- Enter 6 for -9 db
- Enter 7 for -12 db
- Enter 8 for -15 db

■ **Program *41-4, T1 Span Receive Level PAD Assignments**—The receive level of each RDTU can be set for one of several PAD settings:

- Enter 1 for +6 decibel (db) padding
- Enter 2 for +3 db
- Enter 3 for 0 db
- Enter 4 for -3 db (initialized setting)
- Enter 5 for -6 db
- Enter 6 for -9 db
- Enter 7 for -12 db
- Enter 8 for -15 db

Program 42—CO Line To PBX/CENTREX Connection & PBX/CENTREX Access Codes: The system recognizes PBX/CENTREX access codes via Programs 42-1 ~ 8. Program 42-0 informs the software which lines are connected to a PBX or to CENTREX. This combination allows Toll Restriction and Speed Dialing to function properly. This program must be utilized to allow (after flash) PBX/CENTREX features to operate on incoming calls. Initialized Program 42-0 data reads all LEDs OFF for all lines. Program 42 initialized data assigns no access codes to PBX groups.

Program *42 Series—T1 Span Timing Reference Assignments: Timing references for T1 RDTU PCBs are made with the Program *42 series. (Other RDTU parameters are made with the Program *41 series and Program 03.) For proper T1 operation, the equipment at each end of a T1 span line must be synchronized. The DK280 is synchronized (as slave) to the equipment on the other end of the T1 line by the RDTU PCB designated as the Primary Reference in Program *42-1. If a malfunction occurs and Primary Synchronization is lost,

the DK280 automatically switches modes and synchronizes to the equipment connected to the RDTU PCB designated as the Secondary Reference. If the equipment on the other end of the DK280 T1 lines should synchronize to the DK280 clock source, then blanks should be entered in Program *42 1 and 2. In this case, the DK280 clock runs free and is considered the Master Synchronization source. The RCTUC/RCTUD Common Control Unit can support up to six RDTUs, and the the RCTUB unit can support up to two. The RCTUA cannot support the RDTU. (See T1 Section 100-280-400 for more information on Program *42.)

■ **Program *42-1, Primary Timing Reference Assignment:** Assign the Primary Timing Reference with this program.

■ **Program *42-2, Secondary Timing (Backup) Reference Assignment:** Assign the Secondary (Backup) Timing Reference with this program.

NOTE:

*To assign RDTUs as the Master Clock Reference, leave Programs *42-1 and *42-2 blank. Press button/LED 01 to enter blanks.*

Program 43—0 + Credit Card Dialing Option:

Selected station users can bypass their normal Toll Restriction assignments by dialing "0" immediately after seizing a CO line. Both the station and the line must be enabled for this feature with this program. After seizing the line, the station user is required to dial a specific number of digits, which includes the leading 0. This digit-length requirement forces the user to dial a telephone number or a telephone number plus a credit card number; as a result, these calls are billed to the credit card, and operator-placed calls are not billed to the line. The digit length, 1 ~ 30 numbers, is set in Program 60-7. This length is determined by the system's call routing method.

■ If calls are routed via Least Cost Routing (LCR), the digit length should usually be set at 12, the length, including 0, of the telephone numbers dialed on 0+ credit card calls. Do not add the amount of digits in the credit card (usually 14), although these numbers will be dialed by the user after system LCR seizes the line and the system dials the telephone number (see Important Note).

■ When not dialing via LCR, the digit length should usually be 26, the sum of the digits in the telephone (12) and credit card (14) numbers.

IMPORTANT NOTE!

More digits than the length set in Program 60-7 are allowed to be dialed; there is no limit to the amount of digits that can be dialed.

PROGRAMMING PROCEDURES — INSTRUCTIONS

SECTION 100-280-302

Program 44-91 ~ 93—Emergency Bypass of Verified Account Code:

This program exempts numbers up to four digits, such as the emergency 911 number, from Verified Account Code dialing restrictions. As many as three of these special numbers can be programmed. When dialed, these numbers will be sent out the line immediately, bypassing any Verified Account Code dialing restrictions set in Programs 69 and 30, button/LEDs 8 and 14, respectively. If lines are behind CENTREX or PBX, program the appropriate 1- or 2-digit CENTREX/PBX line access code in front of the emergency number. Example: If the PBX line access code is 9, then program 9911 in Program 44-91 ~ 93 to allow 911 to bypass Forced Account Code dial requirements.

NOTES:

1. If Verified Account Codes assigned in Program 69 conflict (duplicate) with emergency or other type telephone numbers set in Program 44-91 ~ 93, Program 44-91 ~ 93 has priority.
2. Toll Restriction and Direct Inward System Access (DISA) parameters requirements are not affected by this program.

Programs 44-1 ~ 8 through 48 Toll Restriction: All Toll Restriction program information is provided later in this chapter.

Programs 50 ~ 56—Least Cost Routing: All Least Cost Routing program information is provided later in this chapter.

Program 58-1—Incoming CO line calls (not recalls) to Attendant Consoles will overflow to a designated attendant console or station port (Program 58-5) if the call is not answered within the time (011 ~ 999 seconds) specified by this Program. The overflow call will ring in on either the In-Trans button (assigned in Program 59) of the console that receives the overflow call, or the Intercom or CO line button of a station.

Program 58-2, LED 01—Attendant Console—Base units can connect to an Electroluminescent (EL) or Extended Graphics Adapter (EGA) Display. This program identifies in software the type of display connected to each console.

Program 58-2, LED 02—Answer Key Operation—The attendant console Answer key can be programmed to answer calls on either a First-in, First-out (FIFO) or a Priority basis. With FIFO, new calls or recalls are stacked in queue in the order in which they are received. This is true regardless of the type of call/recall (CO line call, Intercom call, Hold Recall, etc.). The queued calls will ring to the Answer key in the order in which they are received. With Priority operation, each type of incoming call or recall (CO line call, Intercom call, Hold Recall, etc.) is assigned a specific answering priority ranging from 1 ~ 6. (Call Priority is flexible and is assigned in Program 58-4.) Calls will queue to the attendant in order of their predetermined priority levels. For example, Priority level 1 calls will ring to the attendant before

Priority 2 calls; Priority 2 calls will ring before Priority 3 calls, and so forth.

Program 58-2, LED 03—Each attendant console can be programmed individually to receive a muted ring signal that will alert the console that a new call is waiting while the console is busy on another call. If call-waiting tone is not enabled new calls will not present an audible indication. The call waiting display always displays the number of calls waiting to be answered.

Program 58-4—Attendant Console Answer Key Priority Assignments—Each incoming call or recall type can be assigned a specific Answer key priority level, ranging from 1 ~ 6. If the Answer key is assigned Priority answer operation in Program 58-2, then incoming calls/recalls will ring to the Answer key based on their assigned priority levels. Priority 1 calls have the highest priority while Priority 6 calls have the lowest.

Program 58-5—Attendant Console Overflow Destination—When the attendant console has been placed in the Overflow mode (via the Overflow button), calls will queue to be answered based on the predetermined FIFO or Priority basis. If a call remains in queue for a period longer than the time period set for the Overflow Timer (set in Program 58-1), then the call will overflow to the destination assigned in this program. The assigned destination can be either a station, voice mail, auto attendant, or another attendant console.

Program 59—Attendant Consoles have 24 flexible buttons (12 on left and 12 on the right side of the dial PAD). This program is used to assign each button to an available function or options. Program 59 record sheets define the button options (and codes) available.

IMPORTANT NOTE:

Programs 58 and 59 require Release 2 software installed on Processor RCTUB2 or RCTUC/RCTUD2; Release 1 software is not valid for Attendant Console operation. RCTUA does not provide the Attendant Console feature.

Program 60 (2 ~ 7)—SMDR Output/Account Code Digit Length:

- **SMDR Threshold Time, Item 2—**The time that a call must be in progress before it will register with SMDR can be set to 1 or 10 seconds. The default is 10 seconds.
- **SMDR Output, Item 3—**System output to a Station Message Detail Recording (SMDR) device can include information for both incoming and outgoing calls, or only for outgoing calls. Local and long distance call data will be sent out.
- **Forced/Voluntary/Verified Account Code Digit Length, Item 4—**The Account Code entered at a station can vary in length from 4 ~ 15 digits. For Forced Account Code use, a call will not be completed unless the specified number of digits is

entered by a station user. In the case of Voluntary Account Codes, the Account Code will not be sent to the Station Message Detail Recording (SMDR) call record unless the specified number of digits is dialed. Initialized data assigns a six-digit length for all Account Codes. See Program 69 for Verified Account Codes.

- **Station Message Detail Recording (SMDR) Printout Options, Item 5**—This option selectively deletes local call data and allows long distance/toll call data only to be sent out the SMDR port. The type of long distance/toll call data that prints out is selected by long distance prefix codes 0, 1, 00, or 1 or 0.
- **Direct Inward System Access (DISA) Security Code, Item 6**—The optional security code (1 ~ 15 digits) is required for incoming DISA calls to access outgoing CO lines. If the DISA security code is not set in programming, DISA users can access outgoing lines without dialing a security code. This code is not required for DISA/DISC internal calls to stations. The DISA security code can also be changed from stations enabled in Program 30.
- **Credit Card Call Digit Length, Item 07**—Station users bypassing Toll Restriction with the "0 +" Credit Card Calling feature (Program 43) must dial a predetermined number of digits including the "0." This predetermined number is established with Item 7, and can be 1 ~ 30 digits.

Program 60-8—Call Forward External Remote Destination Change Security (ID) Code—To change a telephone's External Call Forward destination from outside the system, the person that wishes to change the destination must call into a DISA CO line, enter the telephone's Intercom number + #670 and then enter a security code plus the destination telephone number. The security code (1 ~ 15 digits) for each telephone is set with this program.

Program 69—Verified Account Codes: Up to 300 Verified Account Codes may be added, deleted, or changed with Program 69. Each Verified Account Code can be 1 ~ 15 digits long, but cannot exceed the Account Code length requirement set in Program 60-4. The following programs and options should be considered when establishing Verified Account Codes.

- **Account Code Digit Length**—Program 60-4 sets the digit length that must be dialed for all Account Codes: Forced (Verified/Nonverified) and Voluntary (Verified/Nonverified).
- **Full and Partially Verified Account Codes**—Verified Account Codes can contain the same number of digits (full Verified Account Code) or less (partially Verified Account Code) than the

length set in Program 60-4. If partially verified, the first part of the Account Code is verified and the remainder is not. For example, if Verified Account Code 2734 is set in Program 69, but the digit length is set to eight in Program 60-4, then the user must dial 2734 plus any other four digits to enter a partially Verified Account Code. There are many applications for partially Verified Account Codes. For instance, using the code in the example above, the numbers 2734 could be the user's dial restriction code and the remaining four digits could be a customer-client code, a sales order, etc.

- **Verified Account Code Toll Restriction Assignments**—A Toll Restriction Class can be assigned with Program 70 to each of the 300 Verified Account Codes.
- **Verified Account Code Dial Requirement**—Verified Account Code Dial Requirement is assigned on a station-by-station basis in Program 30, LED 14 ON. All Account Codes dialed (Forced or Voluntary) from stations assigned in this program will be verified.
- **Code Change**—Stations selected in Program 30, LED 15 ON, can change Verified Account Codes (VAC) by dialing the following:

Intercom (INT) + # 6 5 9 + 0 0 0 ~ 2 9 9
+ VAC + **Redial (REDIAL)**

- **Verified Account Codes: Forced/Voluntary Program Options**—Any station can dial a Voluntary Account Code after accessing a CO line—by pressing the **Speed Dial** button and dialing **5 0** or by pressing the **Account Code (ACCNT)** button. Forced Account Code requirements are assigned via station and line program options: stations are assigned in Program 30, LED 08 ON; and lines are assigned in Program 15-7. Stations must dial Verified Account Codes when assigned in Program 30, LED 14 ON. Direct Inward System Access (DISA) callers that access outgoing lines can be required to enter Verified Account Codes with Program 30 (LED 08 ON for Port 99).

Program 70—Verified Account Code Toll Restriction Assignments: A Toll Restriction Class can be assigned with this program to each of the 300 Verified Account Codes assigned in Program 69. Therefore, when a Forced Verified Account Code is dialed at a station, the station temporarily assumes the Toll Restriction Class assigned to the Verified Account Code. When Program 70 is initialized, all Verified Account Codes are assigned as not Toll Restricted (data = 00). Verified Account Code Toll Restriction class assignments are not user programmable; so if the assignments are not known, it is recommended to assign a number (block) of Verified Account Codes to each type of Toll

Restriction class. For example:

VACs 000 ~ 050 = no restriction

VACs 051 ~ 100 = total restriction

VACs 101 ~ 150 = Class 1, etc.

Program 77-1—Peripheral Options: (Initialized data reads all LEDs OFF.)

- **Door Lock Time, LED 20**—The Door Lock Relay contact may be programmed to operate for either three or six seconds (applies to PIOU, PIOUS, PEPU, DDCB, and HDCB door lock controls).
- **Port Number/Door Phone/Lock Control Units, LEDs 16 ~ 19**—Door phone/lock existence is defined by this program. Door phone/lock controllers (DDCBs and/or HDCBs) can only exist at Ports 004, 012, 020 and 028, and can only be installed on Circuit 5 of a PDKU, RDSU, PEKU and/or PESU. PDKUs and RDSUs support DDCBs, but not HDCBs. PEKUs and PESUs can support HDCBs, but not DDCBs. After assignment of a DDCB or HDCB, door phone numbers (#151 ~ #159, #161 ~ #163) will effectively replace the station number assignment in Program 04. The door lock option is set via Program 77-2.
- **IMDU Modem, LED 14**—Informs the software that an internal Remote Maintenance modem (IMDU) is installed. Its station number is #19 (unless the access code prefix has been changed with Program 05).
- **280 ADMIN, LED 10**—Enables the system to Upload/ Download RCTU data base using Toshiba 280 ADMIN software package.
- **Door Phone Ring On External Page, LED 08**—If a door phone button is pressed, a ring tone can be enabled or disabled to external paging when the system is in the NIGHT mode. Activation of a Tenant 1 **Night Transfer (NT)** button is required to activate this feature. The Tenant 2 ~ 4 **Night Transfer (NT)** buttons does not apply to door phones.
- **Door Lock Relay/External Page Relay, LED 07**—A relay on the PIOU, PIOUS, or PEPU can be assigned to operate with the Door Lock function or with External Page for mute control. The door lock button is assigned in Program 39; the door lock activation time is assigned in Program 77-1. This door lock function is not associated with the DDCB or HDCB door lock, but is an addition to them.
- **NT Relay, LED 06**—A relay located on the PIOU, PIOUS or PEPU can be assigned to operate in one of two Night Transfer modes (see next item, MOH/NT Relay). In one mode, the relay will activate for 1 second, then be idle for 3 seconds when a line rings (incoming) while the system is in the NIGHT mode. The intended application is to

control an external ringing device at night. Program 78 must have Ring Over External Page activated for this feature. In the second mode, the relay will operate continuously while the NIGHT mode is activated. One application for this mode is to control an external answering machine.

- **MOH/NT Relay, LED 05**—A relay on the PIOU, PIOUS, or PEPU can be assigned to operate in one of two applications. A choice must be made between use for Night Transfer application (see NT Relay, LED 06) or Music-on-Hold (MOH). If used for MOH, the relay will activate when any trunk or station is placed on hold. The intended application is to control a tape player which can be used as a Music-on-Hold source.

Program 77-2—Door Phone and Door Lock Assignments: (Initialized data reads all LEDs OFF.)

- **Door Phone Ring Count, LED 20**—The number of times that a door phone will ring digital and electronic telephones is set with this LED. Light the LED for one ring; turn it OFF for five rings. The default is five rings. See Program 79 to assign which telephones will be rung by door phones.
- **Door Phone Busy Out, LEDs 01, 02, 03, 05, 06, 07, 09, 10, 11, 13, 14, and 15**—Each door phone controller (DDCB or HDCB) can interface with up to three door phones. The system treats each controller as a station. Therefore, this is quite different from all other station arrangements using telephones. The system does not automatically know how many door phones are connected to each DDCB or HDCB, so it must be told. This program is used to enter that information so that a caller will receive fast busy tone if the called door phone does not exist. Door phones 1A, 1B, 1C are numbered #151, #152, #153, respectively, and are connected to the DDCB or HDCB at Port 004. Door phones 2A, 2B, 2C are numbered 154, 155, 156, respectively, and are connected to the DDCB or HDCB at port 012, etc.
- **Door Lock Assignments, LEDs 004, 008, 012, and 016**—Each B-jack on the DDCB and HDCB output can be configured for door lock control. Door lock control buttons for door locks are assigned to electronic or digital telephones in **Program 39**. Door lock activation time is set in **Program 77-1**. Each DDCB requires one PDKU or RDSU circuit, and each HDCB requires one PEKU or PESU electronic telephone circuit. These door locks are not associated with, but are in addition to, the door lock control provided by the PIOU, PIOUS, or PEPU PCB.

Program 77-3—Night Ringing over PIOU External Page Zones: Each tenant's CO lines can be assigned to ring over selected PIOU external page

zones during the NIGHT mode. Lines must be allowed to night ring over external page in Program 78 for this feature to work. Tenant assignments are made in Program *15.

Program 78—CO Line Special Ringing Assignments:

- **Ring Over External Page During Night Mode, Feature 1**—This program selects which lines will activate ringing over external paging facilities during the NIGHT mode (for Tenants 1 ~ 4). The NT Relay on the PIOUS, PIOUS, or PEPUS will also be activated if it is in the 1-second ON/3-seconds OFF mode.
- **DISA CO Line Assignment, Feature 2**—This program assigns lines to be used with the Direct Inward System Access (DISA) features. These lines may be set for DISA operation during the different system modes of DAY, DAY2, and NIGHT. A line will switch to normal ringing after ten seconds if the outside caller does not dial use the DISA feature. Normal function of these lines occurs for outgoing calls.

NOTE:

An optional security code for DISA outgoing lines calls is available via Program 60-6.

- **Ring IMDU Maintenance Modem, Feature 5**—IMDU Remote Maintenance modem can be accomplished with this program. Different alternatives are available for the system modes of DAY, DAY2, and NIGHT. If none of these are selected, the IMDU can still be reached on Station #19 with the DISA feature or by a Ring Transfer from the DSS console attendant or any other station. IMDU Station #19 must be enabled with Program 77-1.
- **Built-in Auto Attendant CO Line Assignment, Feature 6**—This feature selects lines for Auto Attendant operation. There is no limit to the number of lines which can be assigned with Auto Attendant. Different alternatives are available for system modes DAY, DAY2, and NIGHT.

Program 79—Door Phone Ringing: (Initialized data reads all LEDs OFF.)

- **Muted Ring to Busy Electronic and Digital Telephone, LED 20**—If all electronic and digital telephones are busy and a door phone button is pressed, a muted ring tone can be sent to selected digital and electronic telephones, as defined with this program. (Only the lowest port in the appropriate ringing group will mute ring.)
- **Door Phone Ring, LEDs 01 ~ 12**—When a door phone button is pressed, selected digital and/or electronic telephones will ring as assigned with this program. See Program 77-2 for an explanation of the door phone A, B, and C numbering scheme.

Program 80—Electronic and Digital Telephone

Ringing Tones: Distinctive system ringing sends a different ring tone for CO (loop or ground) line ringing than that for intercom, TIE, or DID line ringing. In addition, CO line (loop or ground) ringing at electronic and digital telephones can be different from one phone to another. Three choices are available with Program 80; see the record sheet for the tone frequencies available with each choice.

Programs 81 ~ 89—CO Line Ringing Assignments:

A wide variety of line ringing to stations can be programmed into the system. Nine categories exist, which are DAY IMMEDIATE, DAY DELAY 1, DAY DELAY 2, DAY2 IMMEDIATE, DAY2 DELAY 1, DAY2 DELAY 2, NIGHT IMMEDIATE, NIGHT DELAY 1, and NIGHT DELAY 2. DAY, DAY2 and NIGHT refer to the three modes of the Night Transfer button. DELAY 1 is a 12-second delay of ringing signal to a standard, electronic, or digital telephone, and DELAY 2 is a 24-second delay of ringing. The delay functions are mainly used in CENTREX applications but can be used for other situations. If delayed ringing occurs, the station that initially rings will continue to ring with subsequent delayed ring stations. Initialized data reads all LEDs ON for Port 000 in Program 81 and Port 001 in Program 87; all other LEDs are OFF.

Built-in Auto Attendant-Delay Ringing option: The Built-in Auto Attendant can be programmed to answer incoming calls on a delayed ringing basis in either the DAY, DAY2, or NIGHT mode. To have a line answered by the Auto Attendant on a DELAY 1 or DELAY 2 ring during the DAY mode, for example, first assign the line for the Auto Attendant feature in Program 78-61. To have the line answered by AA on a Delay 1 ring, assign the station ports that must ring for Immediate ringing with Program 81, then assign any other station port with Program 82. To have the line answered by AA on a DELAY 2 ring, assign the station ports that must ring for Immediate and Delay 1 ringing with Programs 81 (immediate) and 82 (12 second delay), then assign any other station port with Program 83 (see Program 81 ~ 89 record sheet notes).

Attendant Console Load Sharing Option: Assign all CO lines (Loop, Ground and DID) that should alternately ring between multiple Attendant Consoles to ring the respective console ports in Program 81, 82 and 87 (see Section 100-280-206, Paragraph 8.20 in the DK280 I/M manual).

Program 93—CO Line Alpha Identification: This program assigns alphanumeric names (such as "WATS BAND 5", "FX TO NY," "MR JONES," etc) to lines. The

names may be up to 16 characters each, and display when the line is being used by an LCD station.

Program 97—Printing Program Data Through SMDR:

Contents of each program can be sent to the SMDR port for a hard copy printout.

Setting Date, Time and Day: The current date, time, and day of the week can be set from an electronic or digital telephone connected to logical Port 000 (usually Station 200). The programming electronic or digital telephone at physical Port 005 cannot make these settings.

2 TOLL RESTRICTION

2.01 The following provides the programmer with an overview of the Toll Restriction feature and step-by-step instructions to fill in the Toll Restriction System Record Sheets.

3 TOLL RESTRICTION OVERVIEW

3.00 TOLL RESTRICTION METHODS

3.01 Toll Restriction screens and selectively restricts outgoing calls using three different methods. Each type of restriction can be programmed for individual stations. Toll Restriction can also be enabled/disabled for each outgoing line in the system.

3.02 Simple Toll Restriction: The first method, Simple Toll Restriction, only involves the first digit dialed. The system can be programmed to reject outgoing calls beginning with 0 or 1 (see Program 48).

3.03 Three-digit Toll Restriction: The second method, Three-digit Toll Restriction, involves the system analyzing the area code dialed, and selectively allowing/disallowing outgoing calls following the criteria defined in Area Code Tables (see Program 46, Codes 2 ~ 4).

3.04 Six-digit Toll Restriction: The third method, Six-digit Toll Restriction, involves the system analyzing the area code and the office code, and selectively allowing/disallowing outgoing calls following the criteria defined in Area Code Tables and Office Code Tables (see Program 46, codes 2 ~ 4 and 6 ~ 8).

NOTE:

Standard telephones that are Toll Restricted should always be forced to use Least Cost Routing (LCR) to place outside calls. This will prevent Toll Restriction defeat when the RRCS circuit times out.

3.10 TOLL RESTRICTION FEATURES

3.11 For description purposes, Toll Restriction is divided into several components, or subfeatures. The subfeatures operate independently of the restriction methods

just described, although they may employ these methods.

3.12 Station Priority Classes 1 ~ 8: Eight classes of Toll Restriction can be defined to assign different levels of priority to individual stations with RCTUC/D. Four classes are supported with RCTUA and RCTUB. Classes can be defined so each is progressively more restrictive by allowing or denying specific area or office codes, calls to long distance information, international calls, and operator assisted calls (Programs 46-10 ~ 80).

3.13 Office Code Exception Tables: Class 1 ~ 8 restrictions can be further modified by defining as many as eight exception tables to allow or deny access to specific office codes that fall within previously restricted area codes (Program 47). Exception office code access is accomplished with the Six-digit Toll Restriction method described earlier.

3.14 Emergency, Information, and Toll-free Long Distance Toll Restriction Override: Toll Restricted stations may be allowed to dial special codes such as 911 for emergency response, 1-411 or 411 for information, or 800 prefix toll-free calls (Program 46).

IMPORTANT!

Always be sure to provide access to emergency numbers such as 911.

3.15 Toll Restriction Override by System Speed Dial: System Speed Dial numbers can be programmed to override Toll Restriction (see Basic System Features, Program 10-1).

3.16 Toll Restriction/Traveling Class Override Codes: Up to two Toll Restriction Override Codes can be defined. When dialed at a toll restricted station, these codes enable the station user to override toll restrictions defined at the station (Program 44B or 45-8 ~ 9). Codes may be changed by stations chosen in programming (see Basic System Features, Program 30).

3.17 Special Common Carrier Authorization: Toll Restriction can be programmed to recognize Other Common Carrier (OCC) telephone numbers, directory numbers, authorization codes, and PBX access codes. The system starts inspecting numbers for Toll Restriction purposes after the recognizable code is dialed (Program 45-3 ~ 6).

4 COMPLETING THE TOLL RESTRICTION SYSTEM RECORD

4.01 The following instructions explain how to complete System Record Sheets used to program the Toll Restriction feature. They are arranged in the same order in which the tables appear in the Toll Restriction System Record Sheets. The following instructions are intended to give a concise general definition of the programming characteristics defined by each record sheet.

PROGRAMMING PROCEDURES — INSTRUCTIONS

SECTION 100-280-302

NOTES:

1. On each record sheet, mark an X in the space provided to indicate that a choice is selected. Unless otherwise specified, this indicates the LED is lit. When appropriate, indicate digits to be entered using the station dialpad.
2. Initialized data and considerations are documented when applicable.

4.10 PROGRAM 44-1 ~ 8—TOLL RESTRICTION/ TRAVELING CLASS OVERRIDE CODES

4.11 Each of the Toll Restriction classes established in **Program 46** can be assigned a code with this program. If one of these codes is entered at a station, the station will assume the code's class for that call. When the call is complete, the station returns to its regular class assigned in **Program 48**. The Traveling Class code data is not sent out the SMDR port and will not print out on station call records. The RCTUC/RCTUD Common Control Unit can support eight Toll Restriction classes, while the RCTUA and RCTUB units can each support four classes.

NOTE:

Stations selected in Program 30, LED 16 ON, can add, change, or delete the codes set in Program 44-1 ~ 8.

4.20 PROGRAM 45-1—TOLL RESTRICTION DIAL PLAN

4.21 A dial plan must be defined for the Toll Restriction software to recognize the typical dialing sequence of long distance/local calls made from the system's home area code, and identify area and office codes. The dialing plan defines several components of a telephone number for long distance calling:

- Long Distance Prefix 1—In most areas, a 1 must be the first digit dialed for long distance calling. In such areas, the area code is dialed right away. The dial plan defines whether the prefix 1 is required for a particular installation's long distance calling.
- Area/Office Code Numbering Schemes—In most places, the middle digit of an area code is 0 or 1, and the middle digit of an office code is 2 ~ 9. Toll Restriction examines the first three-digit sequence dialed and determines whether it is an area code or an office code.
 - If the middle digit is 0 or 1, then the sequence is an area code.
 - If the middle digit does not equal 0 or 1, then the sequence is an office code, and the office code parameters of the selected dialing plan apply.

4.22 An exception to this rule exists. In some places, area and office codes are interchangeable. The middle

digit is always 0 or 1 (see Code 3 selection). In such a case, the system only knows that three digits dialed are an area code if 1 is dialed before them. If 1 is not dialed first, the system knows the three digits are an office code. The dial plan defines the numbering scheme applicable to the installation site.

- Office Codes: Office Code elements are defined as follows:

- N = 2 ~ 9
- X = 0 ~ 9
- NXX = interchangeable with area code; 2nd digit may be 0 or 1.
- NNX = not interchangeable with area code; 2nd digit may not be 0 or 1.

4.23 Equal Access Codes and Special Common Carrier Authorization Codes may be entered as exceptions to the dialing plan in Program 45-3 ~ 6.

4.24 Selections: On the record sheet for Program 45-1, choose one of the following dial plans by marking an X in the space next to the code.

- Plan 1 for dialing plan AC+NXX/1+NNX should be selected if the installation is in a location where a user places a long distance call to a destination outside the area code without dialing 1 before dialing the area code. The user places a long distance call to a destination in the same area code by dialing 1 directly before the office code.
- When using this plan, the system recognizes the following:
 - The first three digits of a ten-digit number is an area code if the middle digit is 0 or 1.
 - The first three digits dialed immediately after a 1 in an eight-digit string is an interchangeable office code (the middle digit may be 0 or 1).
 - A seven-digit string starting with an office code is a local call.
 - An 11-digit string is not recognized.
- Plan 2 for dialing plan 1+AC+NXX/1+NNX should be selected if the installation is in a location where a user places a long distance call to a destination outside the area code by dialing a 1 before dialing the area code. The user places a long distance call to a destination in the same area code by dialing a 1 directly before the office code
- When using this plan, the system recognizes the following:
 - The first three digits following a 1 in an 11-digit number are an area code, if the middle digit is 0 or 1.
 - The first three digits dialed immediately after a 1 in an eight-digit string is an interchangeable office code (the middle digit may be 0 or 1).
 - Digits 5 ~ 7 in an 11-digit string may be an interchangeable office code as well.

- Plan 3 for dialing plan 1+AC+NXX/NNX should be selected if the installation is in a location where a user places a long distance call to a destination outside the area code by dialing a 1 before dialing the area code. The user places a long distance call to a destination in the same area code by simply dialing the number, without a 1 in front. The area and office codes may be interchangeable. The system differentiates between them whenever it sees the digit 1 dialed.
- When using this plan, the system recognizes the following:
 - If 1 is the first number dialed in an 11-digit string, the next three digits are an area code.
 - A ten-digit string is not recognized.
 - The first three digits in a seven-digit string are an office code. (There is no distinction between local call dialing and long distance dialing within the area code.)
 - Digits 5 ~ 7 in an 11-digit string may be an interchangeable office code as well.
- Plans 4 and 5 are not used in the United States.

NOTE:

Program 45-1 must be completed for the Least Cost Routing feature to function properly. See LCR Program 50-1.

4.30 PROGRAM 45-2—TOLL RESTRICTION DISABLE

4.31 Selected lines may be programmed to be exempt from any Toll Restrictions defined in this section. Mark the exempt lines with an X on the record sheet. Initialized data leaves all LEDs OFF, which causes all lines to be affected by Toll Restrictions defined.

NOTE:

Toll Restrictions disabled in this program override station toll restrictions defined in Program 48.

4.40 PROGRAM 45-3 ~ 6—EQUAL ACCESS/SPECIAL COMMON CARRIER NUMBERS AND AUTHORIZATION CODE DIGIT LENGTH

4.41 The purpose of this program is to notify the system of how many digits to ignore before it applies Toll Restriction. This enables the system to allow the use of Special Common Carrier authorization codes.

4.42 Special Common Carrier (SPCC) telephone numbers may be defined to notify the system to modify restrictions when the station user is dialing a long distance carrier. The user dials a code to access the carriers. Original restrictions re-activate after the carrier number is dialed.

4.43 There are two elements Toll Restriction software must verify for a user to successfully complete long distance calling:

- The first five digits of the number dialed to access the long distance special common carrier (SPCC).
- The total number of digits belonging to the authorization code of the SPCC.

4.44 **Items 3 and 5:** Enter the first five digits of the SPCC telephone number in the spaces labeled SPCC1 Telephone Number (item 3) or SPCC2 Telephone Number (item 5) on the record sheet. The initialized state assigns "00000" to items 3 and 5.

4.45 **Items 4 and 6:** Enter each SPCC's authorization code digit length. The number of digits allowed (including the first five specified in items 3 and 5) ranges from 00 ~ 99. Initialized data assigns "00" to items 4 and 6. Enter two digits on the record sheet.

4.46 A restricted station is not able to place a toll call through a long distance carrier by dialing the SPCC1 or SPCC2 telephone number if the station is denied from that number in other toll restriction programs. Upon recognizing the first five digits dialed, Toll Restriction software is notified to allow the number of digits programmed in items 4 or 6 (00 ~ 99, including the first five dialed as SPCC1 or 2).

4.47 The system interprets data to be a seven-digit local call to an SPCC. Only five digits of the seven-digit number are entered; therefore, the last two digits are don't care digits. Any number dialed that has the same first five digits as the carrier, the system will assume the SPCC is being called.

IMPORTANT NOTE!

For items 4 and 6, do not enter more digits than necessary for the authorization code. If too many digits are allowed, toll restrictions may be ignored.

4.50 PROGRAM 45-8 ~ 9—TOLL RESTRICTION OVERRIDE CODE

4.51 Two different codes may be dialed by any station user to override station-specific restrictions.

4.52 Fill in the codes on the record sheet. They must be four digits each.

4.53 Selected stations in the system are able to alter the override code. These stations are defined by Program 30. To change the codes from selected stations:

Code 1: **Intercom (INT) + # 6 5 4 + code + Redial (REDIAL)**

Code 2: **Intercom (INT) + # 6 5 5 + code + Redial (REDIAL)**

NOTE:

Electronic telephone users can use the # button instead of the Redial (REDIAL) button.

4.60 PROGRAM 46-2 ~ 4—TOLL RESTRICTION ALLOWED/DENIED AREA CODES ASSIGNED BY CLASS

4.61 As many as eight Toll Restriction classes can be defined for DK280 systems operating with the RCTUC/RCTUD Common Control Unit (four with the RCTUA or RCTUB units). Each class area code provides for a different combination of restrictions.

4.62 This program defines the area codes allowed or denied for each Toll Restriction class. Area code tables for Classes 1 ~ 8 can each describe area codes that are allowed or denied for the class. The tables (in memory) operate as allow tables. If an area code exists in a table (displays with 4 #), then it is allowed. Anything not displaying is not allowed. Initialized data allows all area codes for each class (all codes are in all tables). All allowed area codes can be displayed (4 #) for each class.

4.63 For each class, choose whether the record table is used to record allowed area codes in memory (ALLOWED) or denied area codes not in memory (DENIED). Enter the area codes that define the set.

4.70 PROGRAM 46-6 ~ 8—TOLL RESTRICTION ALLOWED/DENIED OFFICE CODES ASSIGNED BY CLASS

4.71 This program defines the office codes allowed or denied for each Toll Restriction Class within the home area code. Office code tables for classes 1 ~ 8 can each describe office codes allowed or denied for the class. The tables (in memory) operate as allow tables. If an office code exists in a table (displays with 8 #), then it is allowed. Anything not displaying is not allowed. Initialized data allows all office codes in the home area code for each class.

4.72 For each class, choose whether the record table is used to record allowed office codes in memory (ALLOWED) or denied office codes not in memory (DENIED). Enter the office codes that define the set.

4.80 PROGRAMS 46-10 ~ 80 & 46-11 ~ 81—TOLL RESTRICTION CLASS PARAMETERS (CLASSES 1 ~ 8)

4.81 This program defines parameters of each Toll Restriction class, including dialing plan restrictions and exceptions to previous restrictions.

4.82 Toll Restriction exceptions and dialing plan restrictions may be defined for each class. Programs 46-10 and 46-11 assign Class 1 restriction exceptions and parameters; Programs 46-20 and 46-21 assign Class 2; Programs 46-30 and 46-31 assign Class 3; etc. This program also relates to Program 47. See Program 47 for more explanation.

4.83 Programs 46-10 ~ 46-80. These programs should be run for dial 0, 01, and long distance information (555) assignments.

■ **LED 01:** 0 Restricted—Mark an X next to LED 01 if operator or operator-assisted calls are restricted for the class being defined.

IMPORTANT NOTE!

To allow 0 + dialing (LED 01 must be OFF), codes 020 ~ 099 must be allowed in Program 46, and digit free must be allowed in Program 48. Warning—Allowing 0 + dialing also allows operator-assisted toll calls.

■ **LED 02:** 01 Restricted—Mark an X next to LED 02 if overseas operator or unassisted overseas operator calls are restricted for the class being defined.

■ **LED 03:** 1+AC+555 and AC+555 Allowed—Mark an X next to LED 03 to allow the particular class to call all restricted area codes plus the office code of 555, including out-of-area directory assistance calls. Turning the LED off does not necessarily deny information calls. This may also be accomplished in the office code table and/or the area/office code exception tables.

4.84 Programs 46-11 ~ 46-81. These programs should be run for area/office code exception table assignments.

■ **LEDs 01 ~ 16:** Area Code/Office Code Exception Tables 1 ~ 16—Select the exception tables that apply to the class being defined by marking an X in the box. Exception tables for both area and office codes will be defined in Program 47.

NOTE:

Each class can be assigned any or all of the eight available office code exception tables.

4.90 PROGRAM 47—TOLL RESTRICTION EXCEPTION OFFICE CODES ASSIGNED BY AREA CODES (TABLE 1 ~ 16)

4.91 This program defines exceptions to previously defined office code restrictions for up to 16 area codes, allowing six-digit Toll Restriction. Office codes entered in Tables 1 ~ 16 are opposite of what is defined for the area code by Program 46-2 ~ 8. For instance, if Program 46 denies area code 714, entering office codes 530 and 555 into an exception table for area code 714 will allow those office codes. The RCTUC/RCTUD Common Control Unit can support up to 16 tables, while the RCTUA and RCTUB units can

support eight.

4.92 Each area code with exception office codes requires a table. Each table may hold up to 800 exception office codes.

4.93 Enter the area code and required office codes on the record sheet.

4.100 PROGRAM 48—STATION TOLL RESTRICTION CLASSIFICATION

4.101 This program assigns a combination of two restrictions to each station port defined in the system. The first feature is Digit Restriction and the second is Station Restriction Assignment.

4.102 Digit Restrict Code: If Digit Restrict is enabled for a particular station, the station is able to dial the number of digits defined in the Program 45-1 Toll Restriction dialing plan.

- **1: Enable Digit Restriction**—Enter 1 in the Digit Restrict Code column, next to the port number to enable the restriction for the station. This is used to prevent a user from dialing a second call when dial tone is returned from a CO after the outside party disconnects.
- **2: Disable Digit Restriction**—Enter 0 in the Digit Restrict Code column, next to the port number to disable digit restriction for the station. This allows toll restricted users to dial any number of digits (i.e., to an external voice mail device, computer, etc.).

4.103 Station Restrict Code: The second feature assigns Toll Restriction to individual station ports, in addition to previous restrictions. It includes seven different choices. One of the choices must be entered for each port. Initialized data assigns 0 or no restrictions to all ports. The seven choices are explained as follows.

NOTE:

Station restrictions are overridden by lines disabled as defined in Program 45-2. If a station port has appearance of a line with restrictions disabled, the restrictions will be removed from the station on an individual line basis through Program 45-2.

- **0: No Station Toll Restriction**—Enter 00 in the Station Restrict Code column, next to the port number, to remove Toll Restrictions from the station.
- **1: Area Code Toll Restriction**—Enter 01 in the Station Restrict Code column, next to the port number. If the selected station must be restricted from dialing all area codes.
- **2: Area Code Toll Restriction and "0" or "1" as a 1st or 2nd Digit**—Enter 02 in the Station Restrict

Code column, in the space available for the port number, if the selected station must be restricted from dialing all area codes, and 0 or 1 when used as a first or second digit. This restriction prevents the station from making any long distance calls or operator-assisted calls, in addition to outgoing calls outside the home area code. In applicable areas, this prevents long distance office codes from being dialed (if 1+NNX).

- **3: Class 1 Toll Restriction**—Enter 03 in the Station Restrict Code column in the space provided for the port number, if the selected station will be assigned to the Class 1 level of restriction. Class 1 area and office code restrictions are defined in Program 46, and exception office code tables in 46-10.
- **4: Class 2 Toll Restriction**—Enter 04 in the Station Restrict Code column in the space provided for the port number, if the selected station will be assigned to the Class 2 level of restriction. Class 2 area and office code restrictions are defined in Program 46, and exception office code tables in 46-20.
- **5: Class 3 Toll Restriction**—Enter 05 in the Station Restrict Code column in the space provided for the port number, if the selected station will be assigned to the Class 3 level of restriction. Class 3 area and office code restrictions are defined in Program 46, and exception office code tables in 46-30.
- **6: Class 4 Toll Restriction**—Enter 06 in the Station Restrict Code column in the space provided for the port number, if the selected station will be assigned to the Class 4 level of restriction. Class 4 area and office code restrictions are defined in Program 46, and exception office code tables in 46-40.
- **7: Class 5 Toll Restriction**—Enter 07 in the Station Restrict Code column in the space provided for the port number, if the selected station will be assigned to the Class 5 level of restriction. Class 5 area and office code restrictions are defined in Program 46, and exception office code tables in 46-50.
- **8: Class 6 Toll Restriction**—Enter 08 in the Station Restrict Code column in the space provided for the port number, if the selected station will be assigned to the Class 6 level of restriction. Class 6 area and office code restrictions are defined in Program 46, and exception office code tables in 46-60.
- **9: Class 7 Toll Restriction**—Enter 09 in the Station Restrict Code column in the space provided for the port number, if the selected station will be assigned to the Class 7 level of restriction. Class 7 area and office code restrictions are defined in Program 46, and exception office code tables in 46-70.
- **10: Class 8 Toll Restriction**—Enter 10 in the

Station Restrict Code column in the space provided for the port number, if the selected station will be assigned to the Class 8 level of restriction. Class 8 area and office code restrictions are defined in Program 46, and exception office code tables in 46-80.

NOTE:

The RCTUC/RCTUD Common Control Unit can have as many as eight Toll Restriction classes, and the RCTUA and the RCTUB units can have as many as four.

5 LEAST COST ROUTING

5.01 The following provides the programmer an overview of the Least Cost Routing feature and step-by-step instructions to fill in the Least Cost Routing System Record Sheets. The quantities of LCR plans, CO line groups, etc. vary between RCTU C/D and RCTUA or RCTUB. This section and the LCR program record sheets note these differences when they exist.

6 LEAST COST ROUTING OVERVIEW

6.00 DEFINITION

6.01 The Least Cost Routing (LCR) feature enables the system to automatically route each outgoing voice and data call over common carriers and selected lines. The customer chooses these lines for the specific time of day, and for system users with varying priorities. If the system is programmed properly, LCR can select the most economical route, helping save money. If the best routes are unavailable, users with priority can access more expensive outgoing routes. Several elements of LCR must be defined in programming.

NOTE:

For LCR to function properly, line groups must be created in Program 16; line restrictions set in Programs 40 and 41; and the area dialing plan assigned in Program 45-1.

6.02 LCR General Parameters: Enables features including a warning tone for last choice route number, a comfort dial tone during LCR processing, and the Long Distance Information dialing plan.

6.03 LCR Home Area Code: Notifies LCR software of the area code of the installation site.

6.04 LCR Special Codes: Notifies LCR of special emergency and operator codes that will be automatically routed as a local call, without unnecessary delay.

6.05 Long Distance Information Plan Number:

Notifies LCR software how to route a long distance information call.

6.06 Local Call Plan Number: Notifies LCR software which call routing plan is specifically designed to handle local and special calls.

6.07 LCR Timeout after 0 (Zero) is Dialed: Notifies the system of the time delay to the user after dialing a 0, before a regular operator is accessed.

6.08 LCR Area Codes: As many as 16 separate area code tables can be defined for DK280 systems operating with the RCTUC/RCTUD Common Control Unit (eight for systems with the RCTUA or RCTUB units); one for each available call routing plan. Each table defines the area codes that are handled by the particular routing plan.

6.09 LCR Office Code Exceptions for Area Codes: As many as 16 LCR office code exception tables may be defined with systems operating with the RCTUC/RCTUD Common Control Unit to inform LCR software how to handle specific office codes within area codes. According to the tables defined, specific exception office codes can be routed through a different call plan than the overall area code plan. Up to eight tables can be defined for systems operating with the RCTUA or RCTUB Common Control Unit.

6.10 LCR Schedule Assignments: Call Routing Plans 1 ~ 16 can send the outgoing calls of different groups of stations according to a time schedule, and call route definitions. The RCTUC/RCTUD Common Control Unit can support up to 16 plans, and the RCTUA and the RCTUB units can each support eight.

6.11 LCR Route Definitions: Groups of CO lines assigned to special common carriers, foreign exchange lines, or other special services can be specified as call routes.

6.12 LCR Modified Digit Assignments: Carrier codes can be programmed to dial automatically when a call is placed over the appropriate route. Digits can be added to the front or back of special common carrier codes or other access numbers to make placing calls an invisible process for the user. Digits may also be deleted from the front of the dialed number.

6.13 LCR Station Access Priority Assignments: Each station port defined in the system may be assigned to one of four station priority groups. The groups can have varying access to the defined call routes at different times of day. Each group is partitioned from the other groups.

6.20 CONDITIONS

6.21 A number of conditions apply to LCR assignment. A summary of each is listed here. Paragraph 7, Completing the Least Cost Routing Record Sheets, gives more detailed explanations and examples of how the conditions relate to the programming process.

6.22 If a station has direct line appearances, or pooled CO line buttons programmed to allow direct outgoing line access, LCR will be bypassed using the pooled line or a CO line button.

6.23 LCR accommodates special code dialing, such as 911 for emergency response, 1-411 or 411 for information, or 800 area code toll-free numbers. These calls can be directed to the local call route (see Program 50-31 ~ 35).

IMPORTANT NOTE!

Always provide emergency service access for numbers such as 911.

6.24 Basic System Record programs related to LCR include:

- Program 16 defines which outgoing CO lines are assigned to line groups.
- Program 40 denies a station complete line access. This also applies to LCR.
- Program 41 restricts outgoing line calls to selected stations. These stations may make outgoing calls through LCR. Automatic Busy Redial (ABR) is allowed with this program.

6.25 Standard telephones that are Toll Restricted should be required to use Least Cost Routing (LCR) to place outgoing calls. This prevents Toll Restriction defeat when the RRCS times out.

7 COMPLETING THE LEAST COST ROUTING SYSTEM RECORD

NOTE:

All stations using LCR should be ALLOWED line access in Program 40, and DENIED line access in Program 41.

7.01 The following instructions explain completion of the System Record Sheets used to program LCR. Instructions are arranged in the same order as the Least Cost Routing System Record Sheets. The instructions are intended to give a concise, general definition of LCR characteristics defined by each record sheet.

NOTES:

1. *On each record sheet, enter required data in the space provided to make a selection,*

unless otherwise specified.

2. *The initialized state and considerations are documented on the record sheet.*

7.10 LCR CO LINE PROGRAMMING REFERENCE TABLE

7.11 This table is intended for reference only. Information relevant to LCR is compiled here from Basic System Programming.

1. Under the column labeled "CO lines in Group (001 ~ 144)," enter the numbers of the lines assigned to groups 801 ~ 816 (The RCTUC/RCTUD Common Control Unit can support up to 16 line groups, and the RCTUB and RCTUA units can support up to eight groups.). Refer to the completed record sheet in Program 16 for this information.
2. Under the column labeled "CO Line Type/Comments," enter the service type, the common carrier name, or the line type for each line group, e.g., local line, Foreign Exchange (FX) to 818 (LA), WATS (out of state), etc.
3. Refer to the Basic System Record, Program 40, to restrict stations from incoming and outgoing access of lines, including using LCR. All stations that must use LCR to make outgoing calls must NOT be restricted in this program. These restrictions do apply to LCR.
4. Refer to Basic System Record, Program 41, to restrict stations from accessing outgoing lines, except through LCR. All stations that must use LCR for outgoing calls must be restricted from line access in this program.

7.20 PROGRAM 50 SERIES—LCR DEFINITIONS

7.21 Program 50-1—LCR Parameters: This program defines general operating parameters for LCR software.

NOTE:

Mark an X in the column to indicate which programming button LEDs should be lit. Initialized data leaves all LEDs OFF.

LED Button 01

- ON: LCR software is enabled system-wide.
- OFF: LCR software is disabled. None of the LCR programming referred to by this section is recognized. Dial 9 access assigned in Program 16 is enabled.

LED Button 02

- Not used.

LED Button 03

- ON: LCR routes long distance information (LDI) calls over the plan number specified in Program 50-4.

- OFF: LCR routes LDI calls using area codes specified in route plans 1 ~16, as it would for any other call. (The RCTUC/RCTUD Common Control Unit can support up to 16 route plans, and the RCTUB and RCTUA units can support up to eight.)

LED Button 04

- ON: Station users hear a simulated dial tone immediately after dialing the access LCR code (typically 9), until the first digit of the phone number is dialed. The dial tone is simulated to assure the user of the system's proper operation, but it is not a functional dial tone.
- OFF: Station users hear nothing after dialing the LCR access code until the destination rings or issues a busy signal.

LED Button 05

- ON: The user is notified with a warning tone to indicate that LCR has routed the call over the least desirable route number. The most expensive route is typically programmed to be the least desirable. A user has three choices upon hearing the warning tone:
 - a) Ignore the tone, LCR places the call using the least desirable route.
 - b) Hang up and try later to save money.
 - c) Activate the Automatic Call Back feature. The appropriate line group calls the user back when a more desirable route number becomes available.
- OFF: No warning tone sounds.

7.22 Program 50-2—LCR Home Area Code: Enter the local area code in the spaces provided on the record sheet. Initialized data leaves the home area code blank.

- LCR matches the area code entered here with the LCR route plan containing the home area code in its Area Code Table. (The home area code is later entered into one of the available LCR route plans through Program 51). Thus, LCR is informed of how to handle local calls.
- Typically, systems are configured to have the LCR route plan containing the home area code as the same as the local route plan defined in Program 50-5. This is typically programmed by the installer to be Route Plan Number 1, rather than the default Plan 16.

7.23 Programs 50-31 ~ 35—LCR Special Codes: Five Special Codes may be entered in spaces provided next to 31 ~ 35. The codes may be a maximum of four digits, and should include items such as 911 for emergency calls, and 411 or 1-411 for local information, etc. Initialized data leaves all codes blank.

- When any of these codes are dialed, LCR is flagged to treat the call as follows:
 - The call will be sent over the local call route plan specified in Program 50-5.

- No additional digits need to be dialed. They are not necessary. Therefore, the call is put through immediately.

7.24 Program 50-4—LCR Long Distance Information (LDI) Plan Number: Enter the number of the LCR route plan over which long distance information calls will be routed. Typically, long distance information calls are routed over the local call route defined in Program 50-5. (The RCTUC/RCTUD Common Control Unit can support up to 16 plans, and the RCTUA and the RCTUB units can support up to eight.)

- If the long distance information plan is chosen in Program 50-1, the call is routed as defined by this table.

- Initialized data assigns plan 16 to be the LDI route plan.

7.25 Program 50-5—LCR Local Call Plan Number: Of the 16 route plans available for LCR call processing, one must be defined as the Local Call Plan, typically route plan 1. Enter the number of the plan (1 ~ 16) over which local calls, operator-assisted/0+ calls, and special code calls will be routed.

7.26 Program 50-6—LCR Dial 0 (Zero) Time-out: Enter the maximum number of seconds LCR waits for a user to dial additional digits after a 0, before it routes the call to an operator for assistance. LCR will wait this number of seconds to receive additional digits that will indicate charge calls, collect calls or other 0+ calls.

- The allowed range is 04 ~ 10 seconds. Always enter two digits. Initialized data assigns an LCR dial zero time-out value of 06 seconds.

7.30 ROUTE PLAN OVERVIEW

7.31 Four groups of programs define 16 separate LCR route plans (The RCTUC/RCTUD Common Control Unit can support up to 16 route plans, and the RCTUA and RCTUB units can support up to eight.). They are Programs 51 ~ 54. The purpose of the plan scheme is to provide the system with directions for routing all possible calls, made by all possible users at all possible times of day. 16 separate plans provide the customer flexibility enough to route different area codes and exception office codes over different line groups.

7.32 Initialized data assigns all calls to Plan 16 with the RCTUC/RCTUD Common Control Units (Plan 8 with the RCTUA or RCTUB) Any assignments made in Programs 51 ~ 54 for Plans 1 ~ 15 (Plans 1 ~ 7 with RCTUB or RCTUA) will exempt the defined call from being made on route Plan 16 (Plan 8 for RCTUB or RCTUA). Likewise, any phone number not specified in Routes 1 ~ 15 (1 ~ 7 with RCTUA or RCTUB) automatically defaults to route Plan 16 (8 RCTUA or RCTUB).

PROGRAMMING PROCEDURES — INSTRUCTIONS

SECTION 100-280-302

7.33 Tables for Programs 51 ~ 54 appear on LCR Route Plan Numbers 1 ~ 16. The following instructions reveal how to fill in individual tables within the plans. Each of the following program tables must be completed for all plans.

7.34 Program 51—LCR Area Code Tables: Every route plan can be assigned to define a set of area codes and/or office codes.

- The purpose of Program 51 is to define which area code calls are placed over which LCR Plan Number (1 ~ 16). Initialized data assigns all possible area codes (000 ~ 999) to LCR Plan 16 for systems operating with the RCTUC/RCTUD Common Control Unit (Plan 8 for systems with the RCTUA or RCTUB). Therefore, calls made to all area codes will be routed over route definitions defined in Program 54 for Plan 16, following the time schedule specified by Program 53 for Plan 16 (unless other assignments are made in plans 1 ~ 15).
- For example, any area code entered in a Program 51 LCR area code table for plans 1 ~ 15 is subtracted from Plan 16. An area code cannot be lost. If it is subsequently deleted from Plans 1 ~ 15, LCR software automatically adds it to Plan 16.
- To fill in record sheets for Plans 1 ~ 15:
 - Check the box by Area Code Table.
 - Enter the applicable area codes, three digits per box.

NOTE:

Remember that LCR matches the home area code entered in Program 50-2 with the LCR route plan containing the home area code in its Area Code Table. The home area code must be entered into one of the 16 available LCR route plans through Program 51. Thus, LCR is informed of how to handle local calls. Typically, systems are configured to have the LCR route plan containing the home area code as the same as the local route plan defined in Program 50-5. This usually is programmed by the installer to be Route Plan Number 1, rather than the default Plan 16.

7.35 Program 52—LCR Office Code Exceptions for Specified Area Code: The purpose of the Office Code Exception Table is to enable the customer the flexibility of routing specific office codes through a different call plan than other office codes used with that area code.

- 16 LCR office code exception tables may be defined for the overall LCR scheme for systems operating with the RCTUC/RCTUD Common Control Unit (eight with the RCTUB or RCTUA unit). Any number

of exception code tables may be assigned to each route plan, although each exception table may only be used once system-wide.

- Every route plan can be assigned to define a set of area codes and office code exceptions or a set of office code exceptions.
- This program applies to both examples listed below. In the first case, an office code exception table does not need to be defined in addition to the area codes in Program 51, but it may. In the second case, the plan may only pertain to exception office codes for certain area codes.

Example 1—In the first example, office code exception tables will be defined to the area code table. Use the continuation sheet to define the exception office codes. As many as 16 of the office code exception tables may be linked to a plan, but each exception table may only be used once. When using the continuation sheet, be sure that the same exception table is not assigned to more than one plan.

- Turn to the continuation sheet (that follows Plan 16 record sheet).
- Determine the plan number where the exception office codes will be routed.
- Fill in the area code of the exception office codes in the spaces provided by the correct plan number. These office codes will be routed differently than the overall area code.
- Enter the specific office codes that are to be routed differently.

Example 2—In the second example, the route plan only applies to office code exceptions. The first office code exception table may be documented on the LCR Plan record sheet:

- Check the box on the record sheet next to Office Code Exception Table number.
- Enter the number of the exception table (01 ~ 16). Make sure this table number is not entered on any other plan, or on the continuation sheet.
- Enter the applicable area code.
- Enter the specific office codes that are to be routed differently than the area code.

7.36 Program 53—LCR Schedule Assignments: This program assigns up to three time schedules to each plan. Each time schedule consists of four or six different route definition choices (defined in Program 54) available to the eight station groups (defined in Program 56) (see Program 53 record sheet notes). It may be helpful to complete Program 54 portions of the plans and Program 56 before proceeding.

Typical Installation without time scheduling feature—In most cases, an installation will not require use of the time schedule feature. To reflect this on the record sheets for Plans 01 ~ 16:

- 1: Enter the same **Schedule Start Times** for **Schedules 1 and 2**. Use military time, in the format HH:MM (Hours:Minutes). Fill in all four digits. Initialized data assigns "0000" to all times.
 - If LCR software sees schedules 1 and 2 have the same start times, then it only looks at schedule 1 for route definitions.
- 2: Enter **Route Definition Numbers for Schedules 1 and 2**. Four definitions (route choices) may be entered for each group with RCTUC/D, RCTUA, or RCTUB.
 - LCR Station (Class) Groups 1 ~ 8 are assigned in Program 56.
 - LCR Route Definition numbers 1~ 6 are defined in Program 54.
 - The order in which the route definitions are entered defines the order of LCR line selection. The most desirable route should be entered in the left-most position, and the least desirable route in the right-most position.
 - If "1" is assigned to Station Group 1, and 1 for route definition only, then those assigned will only be able to use Route Definition 1, thereby restricting them during times that route definition 1 is not allowed.
 - Keep in mind that the route definition number is being entered, not the CO line group number. The definitions are assigned in Program 54.

Installation requiring time scheduling feature—When an installation requires the time scheduling feature to be programmed, three "shifts" of route definitions can be assigned per station group. To reflect this on the record sheet, substitute Step 1 of the procedure described for the typical customer with the following:

- 1: Enter the Schedule Start Times for Schedules 1, 2 and 3. Use military time, in the format HH:MM (Hours:Minutes). Fill in all four digits. Initialized data assigns "0000" to all times.
 - Start time for schedule 2 is the stop time for schedule 1.
 - Start time for schedule 3 is the stop time for schedule 2.
 - Start time for schedule 1 is the stop time for schedule 3.

7.37 Program 54—LCR Route Definition: The purpose of this program is to define four (RCTUA or RCTUB) or six (RCTUC/D) different ways of routing calls for each of the LCR plans (see Program 54 record sheet notes). Define each route by selecting and entering:

- 1: **CO Line Group (01 ~ 16):** Refer to the LCR Line Programming Reference Table completed at the beginning of the LCR record sheets.
 - Each line group represents a type of service, e.g., special common carrier, foreign exchange, local line group, etc.
 - Program 16 assigns lines to groups 1 ~ 16 (801 ~ 816).
 - Program 40 denies incoming and outgoing line access to stations, including LCR access.
 - Program 41 allows line access to stations using LCR only for outgoing calls when enabled.
- 2: **Modified Digits Table (1 ~ 12):** Refer to **Programs 55-0, 55-1 and 55-2**. The system handles line groups differently, according to which modified digits table was assigned in **Program 54**.

7.40 PROGRAM 55 SERIES—LCR MODIFIED DIGITS TABLES

7.41 This program defines 6 or 12 modified digits tables for LCR call handling (see Program 55 record sheet notes.). Each modified digits table assigns editing steps that include:

- Deleting a pre-defined quantity of digits from the front of the number dialed (Program 55-0).
- Adding a pre-defined number to the front of the number dialed (Program 55-1).
- Adding a pre-defined number to the end of the number dialed (Program 55-2).

7.42 The purpose of this program is to define call handling so the route definition used by LCR is invisible to the station user. The station user handles all calls the same way. The goal is for LCR to remember the dialing peculiarities of each call route, so the user doesn't need to know.

7.43 Program 55-0—LCR Modified Digits-Delete: Enter the Quantity of Digits that should be deleted from the front of the number dialed for each of the Table Numbers in the Delete Digits Table. The maximum number is ten. Always make the entry two digits.

7.44 Program 55-1—LCR Modified Digits-Add to Front of Dialed Number: Enter the digits that must be added to the front of the number dialed in the Add Digits Table. The maximum quantity of digits is 22, including pauses.

- Length of pause can be indicated by using codes (P1 ~ P8) specified in the Pause Entry Reference Table. Each pause takes two digits of memory space.

- Try to allow for the longest wait, e.g., make the pause longer, rather than shorter, to accommodate the length of time a carrier may need to access the service tones, etc.

7.45 Program 55-2—LCR Modified Digits-Add to End of Dialed Number: Enter the digits that must be added to the end of the number dialed in the Add Digits Table. The maximum quantity of digits is 22, including pauses.

- Length of pause can be indicated by using codes (P1 ~ P8) specified in the Pause Entry Reference Table. Each pause takes two digits of memory space.
- Try to allow for the longest wait, e.g., make the pause longer, rather than shorter, to accommodate the length of time a carrier may need to access the service tones, etc.

7.46 Program 56—LCR Station Group Assignment: The purpose of this program is to assign all defined station ports to one of four or eight LCR Station Groups (see Program 56, record sheet notes).

- Station groups are completely independent of one another. Therefore, each station group must be defined separately.
- Software does not automatically assign the highest, all-inclusive routing priority to Class 1 stations, making all routes available to class 2 ~ 8 stations available to class 1 as well.
- Instead, stations are assigned to independent groups (partitioned). Completely flexible assignment of routing definitions to groups is allowed, with no one group's definition affecting another's. Each group's route definitions are specified to activate separately according to the time schedules set by Program 53.
 - 1: Enter the station group number next to the port number.

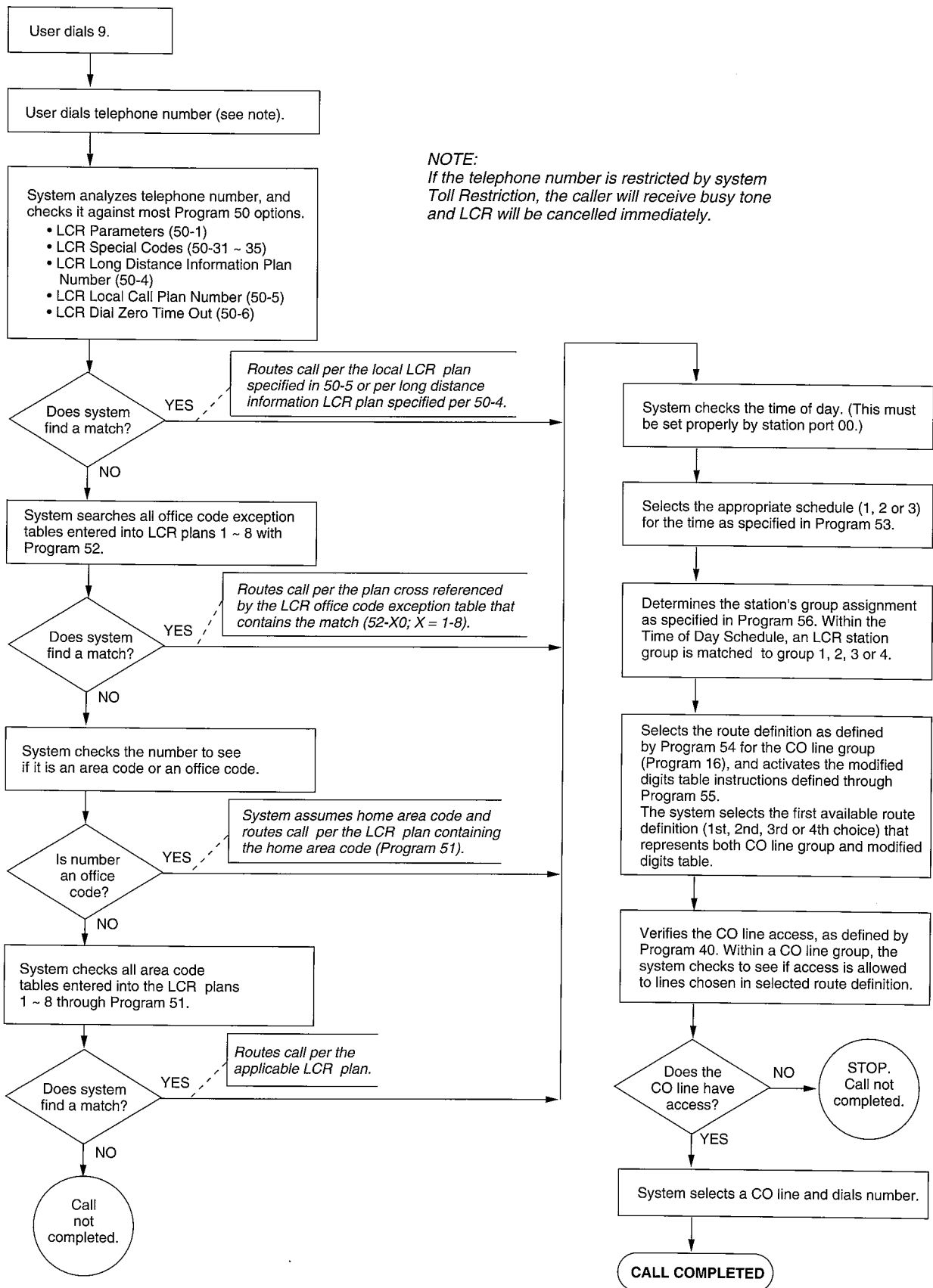

NOTE:
If the telephone number is restricted by system Toll Restriction, the caller will receive busy tone and LCR will be cancelled immediately.

Figure 2-2
LCR OPERATIONAL BLOCK DIAGRAM

Strata[®] *DK280*

PROGRAMMING PROCEDURES

CHAPTER 3 RECORD SHEETS

IMPORTANT!

System configuration can be complex and time consuming. For best results:

Use the software program "280 QUOTE" to provide easy, fast, automated configuration. This runs on an IBM compatible 286 PC, or higher, with a hard disk.

If the above software is not available, use all the Configuration Worksheets in Chapter 2 of the Installation Manual, Section 100-280-202.

IMPORTANT INSTALLATION NOTES:

- 1. Place the RCTU jumper plug into Battery position; otherwise, all programmed data will be lost upon power down.*
- 2. Install PDKU or PEKU in slot 11.*
- 3. Install all Station, Loop Start and Ground Start PCBs from lower to higher numbered slots (left to right). Do not leave empty slots.*
- 4. If DID or TIE T1 channels are used (or anticipated in the future), install RDTU PCBs in the highest numbered slots available. See Installation Section, Chapter 2, Worksheet 2, Tables B and C for slot information details. T1 with only Ground or Loop start channels can be installed as in Step 3 above.*
- 5. Install DID and TIE line analog PCBs starting from the highest numbered vacant slot to the lowest needed (in right to left order).*
- 6. Install PIOUS, PIOUS, PEPUS in any convenient vacant slot.*
- 7. Check Power Factors for each cabinet and for the entire system as explained in the Configuration Chapter of the Installation Section (100-280-202) of this manual.*
- 8. If needed, run Program 91-9 twice to initialize Program data. This must be done if you have just completed step 1 above.*

DK280 RELEASE 2 (R2) SOFTWARE GUIDE

All items available with DK280 R1 software are available with DK280 R2 software; items listed below are available with DK280 R2 software only.

ITEM DESCRIPTION	RELATED PROGRAMS	COMMENTS
ACD with or without MIS	03, 09, 10-4, 11-1 through 9, 14-0 through 9, *14-1, *14-2, 18, 39	ACD only requires RKYS2 and ACD with MIS requires RKYS3 installed on RCTUB2 or RCTU C/D2 PCB. MIS requires RSSU, PIOUS, or PIOU PCB.
Attendant Console	03, 58, 59	Requires RATU interface PCB.
Toshiba Proprietary and SMDI RS-232 Voice Mail interface	03, 10-3 LEDs 09 through 14, *32, 13	Requires an RSSU, PIOUS, or PIOU interface PCB.
Pooled Line Button – no flash if no ring	31 LED 12	If a Pooled line is not programmed to ring a telephone (Prog. 81-89), the Pooled line button will not flash on that telephone when pooled lines ring the DK280 on incoming calls.
User Name Reset with system Power restore	None	The system resets User Names automatically so they display on LCD telephones after system power is turned off and then back on.

TABLE OF CONTENTS

SUBJECT	PAGE
Program Number Index-----	3-iv
Program Listing-----	3-vi

PROGRAMS

PROGRAM	TITLE	PAGE
Program 91-9	System Initialization-----	3-1
Program 91-1	Automatic PCB Recognition/Port Renumber-----	3-2
Program 90	Initializing Programs 00 ~ *99-----	3-3
Program 92	Initializing Speed Dial Numbers, ID Codes Character Message Memory, Timed Reminders, Digital Telephone Volume, and Call Forward Backup RAM-----	3-4
Program 03	Flexible PCB Cabinet and Slot Assignments-----	3-5
Program 00	Software Check/Remote Maintenance Security Code Assignments-----	3-8
Program 01	Logical Station Port Display or Change-----	3-9
Program 02	Physical Station Port Display or Change-----	3-9
Program 04	Logical Port Intercom Number Assignment-----	3-10
Program 05	Flexible Access Code Numbering-----	3-16
Program 09	Auto Attendant Prompt/Station Assignments-----	3-17
Program *09	DID Digit Translation-----	3-18
Program 10-1	System Assignments-----	3-20
Program 10-2	System Assignments-----	3-21
Program 10-3	System Assignments-----	3-22
Program 10-4	(See <i>DK280 ACD Installation and Maintenance Manual</i>)	
Program 11	(See <i>DK280 ACD Installation and Maintenance Manual</i>)	
Program 12	System Assignments — Basic Timing-----	3-23
Program 13	Defining the Message Center-----	3-24
Program 14	(See <i>DK280 ACD Installation and Maintenance Manual</i>)	
Program *14	(See <i>DK280 ACD Installation and Maintenance Manual</i>)	
Program 15	Assigning DP/DTMF, Tenant Service to Individual CO Lines-----	3-25
Program *15	CO Line Tenant Assignments-----	3-26
Program 16	Assign CO Line Groups (Dial 9 or 801 ~ 816)-----	3-27
Program 17	DID / TIE Line Options-----	3-28
Program *17	DID Intercept Port Number (When Caller Dials Vacant or Wrong Number)-----	3-29
Program 18	(See <i>DK280 ACD Installation and Maintenance Manual</i>)	
Program 19	Alternate Background Music Slot Identification-----	3-30
Program 20	Digital Data Port Configuration-----	3-31
Program 21	Modem Pool Port Assignments-----	3-32
Program 22	Data Interface Unit (DIU) Station Hunting (Data Calls Only)-----	3-33
Program 23	Primary Auto Attendant Announcement Device Assignments-----	3-34
Program 24	Secondary Auto Attendant Announcement Device Assignments-----	3-34
Program 25-1	Incoming Auto Attendant Call Overflow Time-----	3-34
Program 26	Built-in Auto Attendant Camp-on Busy Time-----	3-35
Program 27	Digital Telephone Handset Receiver Volume Level-----	3-36
Program 28	DSS Console/Attendant Telephone Assignments-----	3-37
Program 29-1 ~ 8	DSS Console Button Assignments Console No. = _____-----	3-38
Program 29	Initialized DSS Console Button Assignments-----	3-39
Program *29	Add-on Module Button Assignments-----	3-40
Program 30	Station Class of Service-----	3-41
Program *30	Group Page Assignments-----	3-42
Program 31	Station Class of Service-----	3-43
Program *31	Group Pickup Assignments-----	3-44
Program 32	Automatic Preference-----	3-45

PROGRAMMING PROCEDURES — RECORD SHEETS

SECTION 100-280-303

PROGRAM	TITLE	PAGE
Program *32	RS-232 VM Interface Message Center -----	3-46a
Program 33	Station Hunting (Voice Calls Only)-----	3-47
Program 34	Hold/Park Recall Timing-----	3-48
Program 35	Station Class of Service -----	3-49
Program 36	Fixed Call Forward (Voice Calls Only) -----	3-50
Program 37	CO and TIE Line Ring Transfer (Camp-on) Recall Time-----	3-51
Program 38	Digital and Electronic Telephone Keystrip Type-----	3-52
Program 39	Flexible Key Assignment Reference Guide-----	3-55
Program 40	Station CO Line Access -----	3-57
Program 41	Station Outgoing Call Restriction-----	3-58
Program *41-1	T1 Span Frame and Coding Assignments -----	3-59
Program *41-2	T1 Channel Assignments-----	3-60
Program *41-3	T1 Span Transmit (Send) Level PAD Assignments -----	3-61
Program *41-4	T1 Span Receive Level PAD Assignments -----	3-61
Program 42-0	CO Line to PBX/Centrex Connection -----	3-62
Program 42-1 ~ 8	PBX/Centrex Access Codes-----	3-64
Program *42-1	T1 Span Primary Reference Assignments-----	3-65
Program *42-2	T1 Span and Secondary Clock Source Reference Assignments -----	3-65
Program 43	Station/CO Line Credit Card Call Allowed -----	3-66
Program 44-91 ~ 93	Emergency Bypass of Forced/Verified Account Codes -----	3-67
Program 58-1	Attendant Console Overflow Timer -----	3-69
Program 58-2	Attendant Console Display Type/Call Waiting Tone/ANSWER FIFO-----	3-69
Program 58-4	Attendant Console Answer Key Priority Assignments -----	3-69
Program 58-5	Attendant Console Overflow Destination Assignment -----	3-70
Program 59	Attendant Console Flexible Button Codes -----	3-70
Program 60 (2~7)	SMDR Output/Account Code Digit Length-----	3-73
Program 60-8	Call Forward External (Remote Change, Security) ID Code -----	3-74
Program 69	Verified Account Codes-----	3-75
Program 70	Verified Account Code Toll Restriction Assignments -----	3-79
Program 77-1	Peripheral Options (Door Phones/IMDU/PIOU/PIOUS/PEPU)-----	3-80
Program 77-2	Door Phone Busy Signal/Door Lock Assignments-----	3-81
Program 77-3	Night Ringing Over Tenant External Page Zones-----	3-82
Program 78	CO Line Special Ringing Assignments: DISA/IMDU, Night Ringing Over External Page -----	3-83
Program 79	Door Phone Ringing -----	3-84
Program 80	Digital and Electronic Telephone Ringing Tones (CO Line Calls) -----	3-85
Program 81 ~ 89	CO Line/Station Ringing Assignments-----	3-86
Program 93	CO Line Identification -----	3-89
Program 97	Printing Program Data Through SMDR-----	3-91
Program 44-1 ~ 8	Toll Restriction Class (1~8) Traveling Class Override Code Entry -----	3-93
Program 45-1	LCR/Toll Restriction Dial Plan-----	3-94
Program 45-2	Toll Restriction Disable -----	3-95
Program 45-3 ~ 6	Special Common Carrier (SPCC) Numbers and Authorization Code Digit Length -----	3-97
Program 45-8, 9	Toll Restriction Override Code-----	3-98
Program 46-2 ~ 4	Toll Restriction Allowed/Denied Area Codes Assigned by Class -----	3-99
Program 46-6 ~ 8	Toll Restriction Allowed/Denied Office Codes Assigned by Class-----	3-101
Program 46 (10 ~ 80)	Toll Restriction Class Parameters-----	3-103
Program 46 (11 ~ 81)	Toll Restriction Class (1 ~ 8) Parameters-----	3-104
Program 47	Toll Restriction Exception Office Codes Assigned by Area Code-----	3-105
Program 48	Station Toll Restriction Classification-----	3-106
	LCR CO Line Programming -----	3-109
Program 50-1	LCR Parameters-----	3-110
Program 50-2	LCR Home Area Code -----	3-111
Program 50-31 ~ 35	LCR Special Codes-----	3-111

PROGRAMMING PROCEDURES — RECORD SHEETS

SECTION 100-280-303

PROGRAM	TITLE	PAGE
Program 50-4	LCR Long Distance Information (LDI) Plan Number -----	3-112
Program 50-5	LCR Local Plan Number-----	3-112
Program 50-6	LCR Dial Zero Time-out -----	3-112
Program 51	LCR Area Codes (Plans 1 ~ 4) -----	3-113
Program 51	LCR Area Codes (Plans 5 ~ 8) -----	3-114
Program 51	LCR Area Codes (Plans 9 ~ 16 RCTU C/D Only)-----	3-115
Program 52	LCR Office Code Exceptions for Specified Area Codes (1 ~ 4) -----	3-116
Program 52	LCR Office Code Exceptions for Specified Area Codes (5 ~ 8) -----	3-117
Program 52	LCR Office Code Exceptions for Specified Area Codes (9 ~ 12 RCTU C/D Only) -----	3-118
Program 52	LCR Office Code Exceptions for Specified Area Codes (13 ~ 16, RCTU C/D Only)-----	3-119
Program 53	LCR Schedule Assignments for LCR Plan No. 1 and 2 -----	3-120
Program 53	LCR Schedule Assignments for LCR Plan No. 3 and 4 -----	3-121
Program 53	LCR Schedule Assignments for LCR Plan No. 5 and 6 -----	3-122
Program 53	LCR Schedule Assignments for LCR Plan No. 7 and 8 -----	3-123
Program 53	LCR Schedule Assignments for LCR Plan No. 9 and 10 (RCTU C/D Only) -----	3-124
Program 53	LCR Schedule Assignments for LCR Plan No. 11 and 12 (RCTU C/D Only)-----	3-125
Program 53	LCR Schedule Assignments for LCR Plan No. 13 and 14 (RCTU C/D Only)-----	3-126
Program 53	LCR Schedule Assignments for LCR Plan No. 15 and 16 (RCTU C/D Only)-----	3-127
Program 54	LCR Route Definition Tables -----	3-128
Program 55-0	LCR Modified Digits Tables (Delete From Front) -----	3-130
Program 55-1, -2	LCR Modified Digits Table (Add) -----	3-130
Program 56	LCR Station Group Assignments-----	3-131
Table 2-B	Account Code Program Option Matrix -----	3-133
Table 2-C	Override Option Matrix -----	3-133

PROGRAM NUMBER INDEX

FEATURE OR TOPIC	PROGRAM NO.	FEATURE OR TOPIC	PROGRAM NO.
Account Codes	15, 70, 39, 69, 30, 60	Direct Inward Dialing (DID)	*09, 17, *17
ACD (See ACD I&M Manual)		Direct Inward System Access (DISA)	15, 10-1, 60, 78
Add-on Module	*29	Direct Station Selection Buttons	29-1 ~ 29-8, 39
ADMIN (280)	77-1	DISA Code Revision	30
Alarm Sensor	39	Distinctive Station Ringing	10-2, 80
All Call Voice Page	05, 10-2, 31, 39	Do Not Disturb	05, 39
Alternate Point Answer	10-1	Do Not Disturb Override	05, 30
Amplified Conference (External)	10-2, 10-3	Door Lock Control	39, 77-1, 77-2
Attendant Console	03, 58-1, 58-2, 58-4, 58-5, 59	Door Phones	05, 77-1, 77-2, 79
Auto Attendant (Built-in)	09, 10-3, 23 ~ 26, 78, 81 ~ 89	DSS Console Features	03, 28, 29-1 ~ 29-8, 10-2
Automatic Busy Redial (ABR)	10-1, 16, 30, 39	DSS DKT/EKT	28
Automatic Callback	05, 39, 10-2	DTMF and Dial Pulse Assignments	10-1, 15, 30, 39
Automatic Hold	35	DTMF Receiver (RRCS) Operation	03, 12, 15
Automatic Hold Recall	34	DTMF Signal Time, CO lines (80/160 ms)	10-1
Automatic PCB Recognition	91	DTMF Signal Time, VM Ports (80/160 ms)	10-2
Automatic Preference	32	DTMF Tone/No Tone/Single Tone Return	10-2
Automatic Release Hold/VM Port	15	DTMF Continuous Tone (2000-series DKT)	35
Background Music	05, 10-2, 19, 39	Emergency Numbers	44-91 ~ 93
Busy Override	05	Exclusive Hold	10-1
Busy Station Transfer/Ringing	35	Executive Override	05, 10-2, 30
Busy Tone Cadence Change	10-2	External Page Interface	10-2, 77-1, 78
Call Blocking (VM Ports)	31	External Zone Paging	05, 77-1
Call Forward External	12, 60-8	Fixed Call Forwarding	36, 39
Call Forwarding (all types)	10-2, 36, 39	Flash Timing	12
Call Forward Blocking with Handsfree	35	Flexible Access Code Numbering	05
Call Pickup	10-1, 15, 39	Flexible Button Assignments	38, 39
Call Transfer with Camp-on	10-1	Flexible Intercom Numbering	04, 05, 39
Camp-on	10-2, 37	Flexible Line Ringing Assignment	81 ~ 89
Centrex/PBX Compatible	42-0, 42-1 ~ 8	Flexible PCB Slot Configuration	91-9, 91-1, 03
Centrex Ringing Repeat	10-1	Forced and Voluntary Account Codes	15, 30, 60, 39
CO/Centrex/PBX Feature Buttons	39, 42-0, 42-1 ~ 8	Group Paging	05, *30
CO Line Access	39, 40, 41	Group Pickup	*31
CO Line Alpha Identification	93	Handsfree Answerback	17, 31
CO Line Groups	16	Hold/Park Recall Timing	34
CO Line Reseize Guard Time	10-1, 42-0	Hunting	10-2, 22, 33
CO Line Queuing	05, 16	Immediate Transfer with Soft Key	10-2
CO Line Ringing	78, 81 ~ 89	Initialization (system programs)	91-9, 91-1, 90
Conferencing	10-1, 10-2, 15	Initialization (system/personal memory)	91-9, 92
Credit Card Calls (0 + dialing)	43, 60-7	Intercom Access	39
Data Port/DIU Configuration	20, 21, 22, 39	Intercom Volume	10-1
DAY/NIGHT Mode	10-2, 78, 81 ~ 89	Keystrips	38
Delayed Ringing	82, 83, 85, 86, 88, 89	Least Cost Routing	50 ~ 56
Digital Telephone	03, 27, 30, 38, 80, 92-5	Liquid Crystal Display Features	10-2, 35, 39

PROGRAM NUMBER INDEX (continued)

FEATURE OR TOPIC	PROGRAM NO.	FEATURE OR TOPIC	PROGRAM NO.
Logical Port Display/Change	01	Saved Number Redial	39
Message Center	13	Security Code (CF-EXT.)	60-8
Message Waiting/Flash	10-2, 12, 35, 39	Security Code (DISA)	30, 60
Microphone Control	30, 39	Security Code (R. Maintenance)	00
Modem Pool Port Assignment	21	Slot Assignment	03
Music-on-Hold	77-1	Software Version	00
Night Pickup Code	05	Speakerphone Assignment	30
Night Ringing over External Page	15, 77-1, 78	Speed Dial	10-1, 30, 39
Night Transfer	29, 39, 77-1, 78	Speed Dial Clear	92
Off-hook Call Announce	03, 30, 31	Speed Dial Entry Timeout	10-3
On-hook Dialing	32	Standard Telephone Ringing Options	10-2
Outgoing Call Restriction	41	Station Class of Service	30, 31, 35
Paging-DKT/EKT	31, 39	Station Hunting (Data Calls)	22
Passwords-Remote Programming	00	Station Hunting (Voice Calls)	33
Pause Timing	12, 39	Station Message Detail Recording	60-2~7, 97
PBX Access Code	42-1 ~ 42-8	SMDI VM Interface	03, 10-2, *32
PBX Backup	42-0	T1 Assignments	*41, *42
Physical Port Display/Change	02	Tandem CO Line Connections	10-1, 15
Pooled CO Lines	16, 39	Tenant Service	*15, 39, 77-3
Pooled Line Buttons	16, 39	TIE Lines	03, 17, 37
Pooled Line LED - No Flash	31	Toll Restriction	10-1, 30, 41 ~ 48
Port/Station Number Assignment	04, 91-9	Toll Restriction Override	10-1, 30, 39
Privacy/Non-Privacy	31, 30, 39	Toll Restriction Override Code Revision	30
Privacy Override	10-2, 30, 31	Toshiba Proprietary VM Interface	03, 10-2, *32
Private CO Lines	39	Transfer Privacy	10-1
Redial Last Number	39	Traveling Class	44-1 ~ 8
Relay Service	77-1	Traveling Class Code Revision	30
Remote Administration		Verifiable Account Codes	15, 30, 60, 69, 70
and Maintenance	00, 77-1, 78	Verifiable Account Codes Revision	30
Repeat Last Number Dialed	30, 39	Voice Mail Interface	10-2, 31, 39
Ring Transfer	10-1, 37	Voice or Tone Signaling	05, 10-1, 10-2
Ringing Repeat	10-1	Volume Reset (Digital Telephones)	92-5
Ring Tones	80	Volume Set (Digital Telephones)	72
Ring Assignments	81 ~ 89	Voluntary Account Codes	39
Ringing Line Preference	32, 81 ~ 89		

PROGRAMMING PROCEDURES

SECTION 100-280-303

Table 3-A — PROGRAM LISTING
(IN NUMERICAL ORDER WITH SECTIONS CROSS-REFERENCED)

Program Number	Title (Applicable Sections)	Program Number	Title (Applicable Sections)
00	Software Check/Remote Maintenance Security Code Assignments (Basic System)	*15	CO Line Tenant Assignments (Basic System)
01	Logical Station Port Display and Change (Basic System)	16	Assigning CO Line Groups (Dial 9 or 801 ~ 816) (Basic System)
02	Physical Station Port Display and Change (Basic System)	17	DID/TIE Line Options (Basic System)
03	Flexible PCB Slot Assignments (Basic System)	*17	DID Intercept Port Number (Basic System)
04	Port/Station Intercom Number Assignment (Basic System)	18	ACD – See ACD I/M Manual (Basic System)
05	Flexible Access Code Numbering Assignments (Basic System)	19	Alternate Background Music (BGM) Slot Identification (Basic System)
09	(Built-in) Auto Attendant Prompt/Station Assignments (Basic System)	20	Digital Data Port Configuration (Basic System)
*09	DID Digit Translation (Basic System)	21	Modem Pool Port Assignments (Basic System)
10-1	System Assignments, Part 1 of 3 (Basic System)	22	Data Interface Unit Station Hunting (Data Calls) (Basic System)
10-2	System Assignments, Part 2 of 3 (Basic System)	23	Primary (Built-in) Auto Attendant Announcement Device Assignments (Basic System)
10-3	System Assignments, Part 3 of 3 (Basic System)	24	Secondary (Built-in) Auto Attendant Announcement Device Assignments (Basic System)
10-4	ACD – See ACD I/M Manual (Basic System)	25-1	Incoming Auto Attendant Call Overflow Time (Basic System)
11	ACD – See ACD I/M Manual (Basic System)	26	Built-in Auto Attendant Camp-on-Busy Time (Basic System)
12	System Assignments – Basic Timing (Basic System)	27	Digital Telephone Handset Receiver Volume Level (Basic System)
13	Defining the Message Center (In band/RS-232) (Basic System)	28	DSS Console/Attendant Telephone Assignments (Basic System)
14	ACD – See ACD I/M Manual (Basic System)	29	DSS Console Button Assignments (Basic System)
*14	ACD – See ACD I/M Manual (Basic System)		
15	Assigning DP/DTMF, Tenant Service to Individual CO Lines (Basic System)		

Table 3-A — PROGRAM LISTING
(IN NUMERICAL ORDER WITH SECTIONS CROSS-REFERENCED)(continued)

*29	Add-on Module (ADM) Button Assignments <i>(Basic System)</i>	*41-4	T1 Span Receive Level Pad Assignments <i>(Basic System)</i>
30	Station Class of Service <i>(Basic System)</i>	42-0	CO Line to PB3X/Centrex Connection <i>(Basic System)</i>
*30	Group Page Assignments <i>(Basic System)</i>	42-1~8	PBX/Centrex Access Code <i>(Basic System)</i>
31	Station Class of Service <i>(Basic System)</i>	*42-1	T1 Span Primary and Secondary Clock Source Reference Assignments <i>(Basic System)</i>
*31	Group Pickup Assignments <i>(Basic System)</i>	*42-2	T1 Secondary Timing (Backup) Reference Assignments <i>(Basic System)</i>
32	Automatic Preference <i>(Basic System)</i>	43	Station/CO Line Credit Card Call Allowed <i>(Basic System)</i>
*32	RS-232 VM Interface Message Center <i>(Basic System)</i>	44-91~93	Emergency Bypass of Forced/Verified Account Codes <i>(Basic System)</i>
33	Station Hunting (Voice Calls Only) <i>(Basic System)</i>	44-1~8	Toll Restriction Traveling Class Override Codes <i>(Toll Restriction)</i>
34	Hold/Park Recall Timing <i>(Basic System)</i>	45-1	LCR/Toll Restriction Dial Plan <i>(Toll Restriction)</i>
35	Station Class of Service <i>(Basic System)</i>	45-2	Toll Restriction Disable <i>(Toll Restriction)</i>
36	Fixed Call Forward <i>(Basic System)</i>	45-3~6	Special Common Carrier Numbers and Authorization Code Digit Length <i>(Toll Restriction)</i>
37	CO and TIE Line Ring Transfer (Camp-on) Recall Time <i>(Basic System)</i>	45-8~9	Toll Restriction Override Code <i>(Toll Restriction)</i>
38	Digital and Electronic Telephone Buttonstrip Type <i>(Basic System)</i>	46-2~4	Toll Restriction Allowed/Denied Area Codes Assigned by Class <i>(Toll Restriction)</i>
39	Flexible Key Assignment Reference Guide <i>(Basic System)</i>	46-6~8	Toll Restriction Allowed/Denied Office Codes Assigned by Class <i>(Toll Restriction)</i>
40	Station CO Line Access <i>(Basic System)</i>	46-10 ~ 80	Toll Restriction Class Parameters <i>(Toll Restriction)</i>
41	Station Outgoing Call Restriction <i>(Basic System)</i>	46-11 ~ 81	Toll Restriction Class Parameters <i>(Toll Restriction)</i>
*41-1	T1 Span Frame and Coding Assignments <i>(Basic System)</i>	46-21, -31, -41, -51, -61, -71, -81	Toll Restriction Classes 2 ~ 8 <i>(Toll Restriction)</i>
*41-2	T1 Channel Assignments <i>(Basic System)</i>		
*41-3	T1 Span Transmit Level Pad Assignments <i>(Basic System)</i>		

PROGRAMMING PROCEDURES

SECTION 100-280-303

Table 3-A — PROGRAM LISTING
(IN NUMERICAL ORDER WITH SECTIONS CROSS-REFERENCED)(continued)

47	Toll Restriction Exception Office Codes by Area Codes <i>(Toll Restriction)</i>	58-4	Attendant Console Answer Key Priority Assignments <i>(Attendant Console)</i>
48	Station Toll Restriction Classification <i>(Toll Restriction)</i>	58-5	Attendant Console Overflow Destination Assignment <i>(Attendant Console)</i>
50-1	Least Cost Routing Parameters <i>(Least Cost Routing)</i>	59	Attendant Console Flexible Button Codes <i>(Attendant Console)</i>
50-2	Least Cost Routing Home Area Code <i>(Least Cost Routing)</i>	60	Station Message Detail Recording Output/Account Code Digit Length <i>(Basic System)</i>
50-31~35	Least Cost Routing Special Codes <i>(Least Cost Routing)</i>	60-8	Call Forward External (Remote Change, Security) ID Code <i>(Basic System)</i>
50-4	Least Cost Routing Long Distance Information Route Plan Number <i>(Least Cost Routing)</i>	69	Verified Account Codes <i>(Basic System)</i>
50-5	Least Cost Routing Local Call Plan Number <i>(Least Cost Routing)</i>	70	Verified Account Code Toll Restriction Assignments <i>(Basic System)</i>
50-6	Least Cost Routing Dial Zero Timeout <i>(Least Cost Routing)</i>	77-1	Peripheral Options 280 ADMIN <i>(Basic System)</i>
51	Least Cost Routing Area Codes <i>(Least Cost Routing)</i>	77-2	Door Phone Busy Signal/Door Lock Assignments <i>(Basic System)</i>
52	Least Cost Routing Office Code Exceptions for Specified Area Code <i>(Least Cost Routing)</i>	77-3	Night Ringing Over Tenant External Page Zones <i>(Basic System)</i>
53	Least Cost Routing Schedule Assignments <i>(Least Cost Routing)</i>	78	CO Line Special Ringing DISA IMDU/Night Ringing Over External Page Assignments <i>(Basic System)</i>
54	Least Cost Routing Route Definition Tables <i>(Least Cost Routing)</i>	79	Door Phone Ringing <i>(Basic System)</i>
55-0	Least Cost Routing Modified Digits Table (Delete) <i>(Least Cost Routing)</i>	80	Digital and Electronic Telephone Ringing Tones <i>(Basic System)</i>
55-1~2	Least Cost Routing Modified Digits Table (Add) <i>(Least Cost Routing)</i>	81 ~ 89	CO Line Station Ringing Assignments <i>(Basic System)</i>
56	Least Cost Routing Station Group Assignments <i>(Least Cost Routing)</i>	90	Initializing Program 00 ~ *99 <i>(Basic System)</i>
58-1	Attendant Console Overflow Timer <i>(Attendant Console)</i>	91	Automatic PCB Recognition/Port Renumber and Total Initialization <i>(Basic System)</i>
58-2	Attendant Console Display Type (EL/EGA) ANSWER FIFO, and Call Waiting Tone <i>(Attendant Console)</i>		

Table 3-A — PROGRAM LISTING
(IN NUMERICAL ORDER WITH SECTIONS CROSS-REFERENCED)(continued)

- | | |
|-----------|--|
| 92 | Initializing Speed Dial Numbers, VM ID Codes, Character Message Memory, Timed Reminder, Digital Telephone Volume Levels, and CO Line Identifications
<i>(Basic System)</i> |
| 93 | CO Line Identification
<i>(Basic System)</i> |
| 97 | Program Printing Through SMDR
<i>(Basic System)</i> |

CHAPTER 3

RECORD SHEETS

INITIALIZATION PROGRAM 91-9 — SYSTEM INITIALIZATION

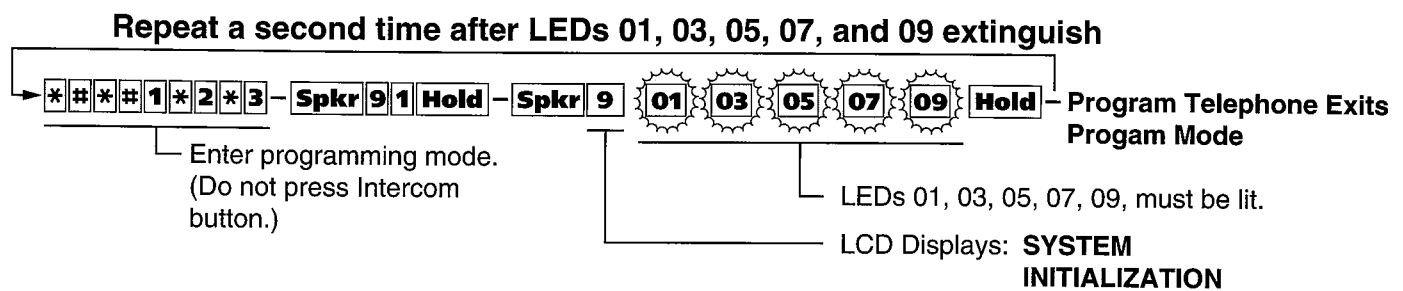

NOTES:

1. Run this program for all new installations — but not while system is in service.
2. This program will run **Program 03** and assigns codes to all PCBs (except options) installed. This program will erase all **Program 03** option codes for piggyback PCBs, DSS consoles, RRCS, etc, except the RCOS PCB Code (17). **Program 03** should be run (after **Program 91-9** is run) for PCBs which have options, such as Dual-tone Multi-frequency Receivers (RRCS), DSS consoles, etc.
3. **Program 91-9** can also be run to bring back logical and physical ports to their initialized settings.
4. If entering a customer database into RCTU memory before other system PCBs (stations, lines, options) are installed, it will be necessary to run **Program 03** after **Program 91-9** to identify which PCBs are installed in each cabinet slot.

WARNING!

This Program **INITIALIZES** all Programs (00 * ~ *99) including 01, 02, 03, 90, 91-1, 92. All calls will be dropped if this Program is run while the system is in service.

INITIALIZATION PROGRAM 91-1 — AUTOMATIC PCB RECOGNITION/PORT RENUMBER

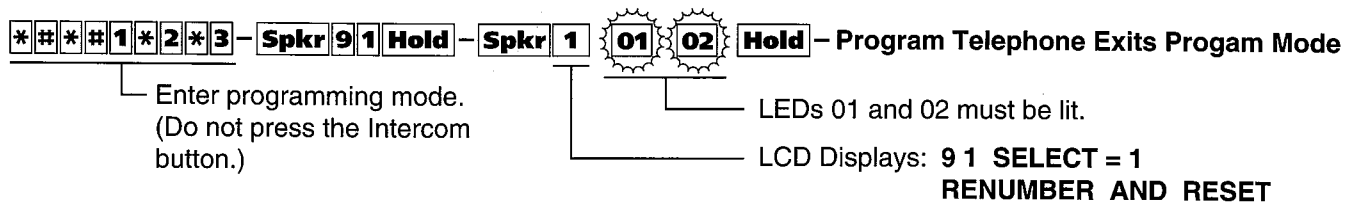

NOTES:

1. Running **Program 91-9** will run **Program 91-1**.
- Important** 2. On new installations, run this program after PCBs have been installed, but not while system is in service; then run **Program 90** to initialize **Program 38**.
3. This program should be run before **Program 03**. **Program 91** will automatically assign PCBs with no options to the cabinets and slots in which they reside. **Program 03** must be run for PCBs which have options (except for RCOS), such as Dual-tone Multi-frequency Receivers (RRCSs), DSS consoles, etc.
4. Run **Program 91** to bring back logical and physical ports to their (**Programs 01 and 02**) initialized settings, but not while system is in service.
5. This Program does not change Intercom numbers set in **Program 04**.

WARNING!

Running this Program (91-1) will drop all calls. This Program **INITIALIZES** Programs 01, 02 but not Program 04. This Program does not erase Program 03 option PCB codes. (Examples: If Slot 00 is assigned code 92, the code will not be erased when Program 91-1 is run. Also, if a RCTU PCB has a RRCS piggyback installed, Program 90-1 will not change a code from 91 to 92 or 93, etc.)

INITIALIZATION PROGRAM 90 — INITIALIZING PROGRAMS 00 ~ *99

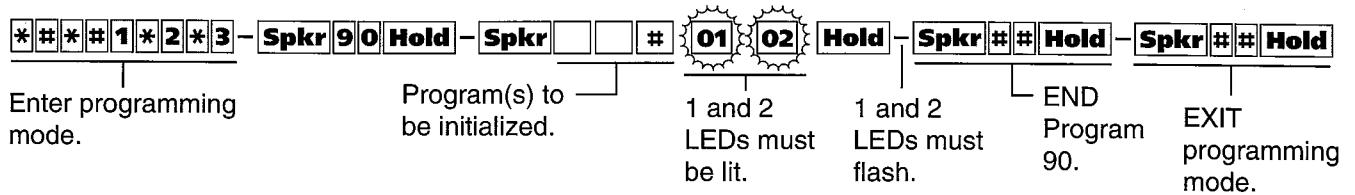

IMPORTANT

This Program is primarily used to initialize individual Programs in DK280 software. To initialize one program at a time, just enter the individual program number, then #, then Key 01 and 02 plus Hold.

*Initialize Programs 00 ~ *99 every time¹:*

- A new system is installed
- To bring a system's programming back to the default setting.

Specify the range as follows: [0][0][*][*][9][9] (see WARNING! note)



NOTES:

1. Running **Program 91-9** will run this Program to initialize **Programs 00 * *99**.
2. Always complete **Program 90** at new system installs, before programming anything else. Skipping this step may cause erratic system behavior.
3. Follow instructions in **Table 1-E (Section 100-280-301)** to clear this data.
4. To initialize all Programs, a ****** must be entered between **00** and **99**.
5. Each ***** program record sheet immediately follows the program record sheet having the same number (Example ***31** follows **31** record sheet). However in system memory, all ***** programs follow **Program 99**. Therefore, when initializing star ***** program ranges, they must be initialized separately from non-star Programs unless initializing all system Programs (**00* *99**). Example, to initialize **Programs 30, *30, 31, *31, and 32**, initialize the range (**30 * 32**), **Programs 30, 31, 32**; and the range (***30 * *31**), **Programs *30 and *31**.

WARNING!

Running this program will erase customer data. If Program 01, 02, or 91 is initialized by running Program 90, calls will be dropped.

INITIALIZATION PROGRAM 92— INITIALIZING SPEED DIAL NUMBERS, ID CODES CHARACTER MESSAGE MEMORY, TIMED REMINDERS, DIGITAL TELEPHONE VOLUME, AND CALL FORWARD BACKUP RAM

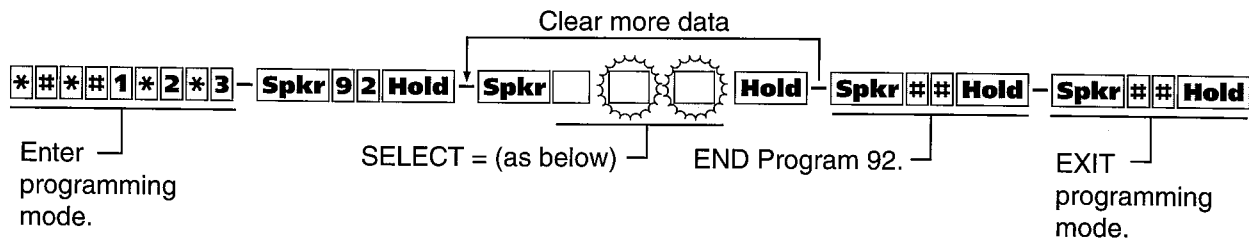

- | | | | | | |
|---|--|----|--|---|--|
| 1 | 01 | 03 | Clears Station Speed Dial, Voice Mail ID Codes, and LCD memos assigned to Station Speed Dial numbers. | | |
| 2 | 01 | 04 | Clears System Speed Dial and LCD memos assigned to System Speed Dial numbers. | | |
| 3 | 02 | 03 | Clears Character Message Memory (Station and System) and User Name/Number Display. | | |
| 4 | 02 | 04 | Clears Timed Reminders. | | |
| 5 | 01 | 05 | Resets digital telephone volume levels to initialized settings, specifically, speaker volume levels for Intercom Tone/BGM, busy override (muted ring), and ringing volume to approximately mid-range on all DKTs. ⁵ | | |
| 9 | 03 | 04 | <table border="1" style="display: inline-table; vertical-align: middle;"> <tr> <td style="text-align: center;">H</td> <td>Power OFF
5 seconds;
then Power ON</td> </tr> </table> ⁴ Clears Call Forward Memory (all stations). | H | Power OFF
5 seconds;
then Power ON |
| H | Power OFF
5 seconds;
then Power ON | | | | |

NOTES:

1. Running **Program 91-9** will run all of **Program 92** (1 ~ 9) options.
2. **IMPORTANT:** It is mandatory to complete all parts of **Program 92** at every new system install. If **Program 92** is not completed certain feature operations may cause erratic system behavior.
3. Use the instructions in **Table 1-F (Section 100-280-301)** to clear this data.
4. **Program 92-9** does not affect Call Forward External or Fixed Call Forward settings.
5. **Program 92-5** does not affect digital telephone handset receiver volume levels. Use **Program 27** to set off-hook handset receiver volume levels for digital telephones.
6. Power OFF and ON is required to clear telephone LCD Call Forward Displays and Call Forward button LEDs. Call Forward memory is cleared when **Program 92-9** is run, even if system power is not cycled.

WARNING!

Running this program will ERASE customer data.

PROGRAM 03 — FLEXIBLE PCB CABINET AND SLOT ASSIGNMENTS

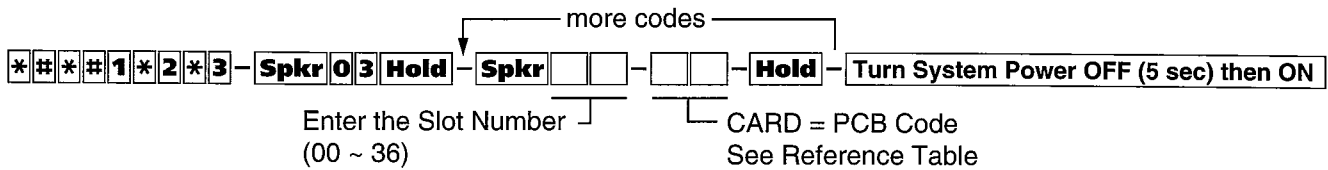

BASE CABINET (CABINET 1)

SLOT NUMBER	R11	RCTU	S11 ⁹	S12	S13	S14	S15 ¹¹	S16 ¹¹
PCB CODE		91	61	61	17	11		
PCB TYPE								
OPTIONS								
STATION/TIE/DID PORT NUMBERS								
CO/TIE/DID LINE NUMBERS								

EXPANSION CABINET (CABINET 2)

SLOT NUMBER	S21	S22	S23	S24	S25	S26	S27 ⁵	S28 ⁵
PCB CODE								
PCB TYPE								
OPTIONS								
STATION/TIE/DID PORT NUMBERS								
CO/TIE/DID LINE NUMBERS								

EXPANSION CABINET (CABINET 3)

SLOT NUMBER	S31	S32	S33	S34	S35	S36	S37 ⁵	S38 ⁵
PCB CODE								
PCB TYPE								
OPTIONS								
STATION/TIE/DID PORT NUMBERS								
CO/TIE/DID LINE NUMBERS								

REFERENCE TABLE

PCB	CODE	PORTS/TYPE
RCOU, RGLU, PCOU	11 ⁹	4 GRND/LOOP LINES
RCOU/RCOS	17 ⁹	8 LOOP CO LINES
RDDU ⁷	16 ⁹	4 DID LINES
PEMU/REMU ⁷	13 ⁹	4 TIE LINES
PEKU	21 ⁹	8 STATIONS
PEKU (EOCU)	22	8 STATIONS
PEKU w/DSS	23	8 STATIONS
PEKU (DSS, EOCU)	24	8 STATIONS
PESU	25 ⁹	6 STATIONS
PESU (OCA)	26	6 STATIONS
RDSU	27 ⁹	8 STATIONS
RDSU (OCA, DIU)	28	8 STATIONS
PSTU/RSTU	31 ⁹	8 STATIONS
PIOU, PIOUS/RSSU ⁶ , PEPU ⁵	41 ⁹	REMOTE MAINTENANCE (TTY)
PIOU/PIOUS/RSSU ⁶	42	MIS FOR ACD (TTY) ¹²
PIOU/PIOUS/RSSU ⁶	43	RS-232 VM INTERFACE (TTY) ¹²
PDKU	61 ⁹	8 STATIONS
PDKU (OCA, DIU)	62	8 STATIONS
PDKU (DSS, OCA, DIU)	64	8 STATIONS
RDTU ⁷	71 ⁹	8 T1 CHANNELS
RDTU ⁷	72	16 T1 CHANNELS
RDTU ⁷	73	24 T1 CHANNELS
RCTU	91 ⁹	NONE
RCTU ² (4-CKT RRCS)	92	NONE
RCTU ² (8-CKT RRCS)	93	NONE
RCTU ² (12-CKT RRCS)	94	NONE
NONE	00 ⁹	00
RATU ⁷ (RELEASE 2 AND ABOVE)	51 ⁹	ATTENDANT CONSOLE PCB ¹²

See notes following Program 03 record sheets.

PROGRAM 03 — FLEXIBLE PCB CABINET AND SLOT ASSIGNMENTS (continued)

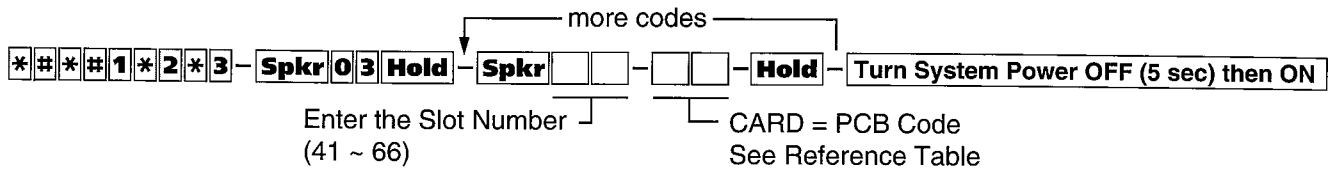

EXPANSION CABINET (CABINET 4)

SLOT NUMBER	S41	S42	S43	S44	S45	S46	S47 ⁸	S48 ⁸
PCB CODE								
PCB TYPE								
OPTIONS								
STATION/TIE/DID PORT NUMBERS								
CO/TIE/DID LINE NUMBERS								

EXPANSION CABINET (CABINET 5)

SLOT NUMBER	S51	S52	S53	S54	S55	S56	S57 ⁸	S58 ⁸
PCB CODE								
PCB TYPE								
OPTIONS								
STATION/TIE/DID PORT NUMBERS								
CO/TIE/DID LINE NUMBERS								

EXPANSION CABINET (CABINET 6)

SLOT NUMBER	S61	S62	S63	S64	S65	S66	S67 ⁸	S68 ⁸
PCB CODE								
PCB TYPE								
OPTIONS								
STATION/TIE/DID PORT NUMBERS								
CO/TIE/DID LINE NUMBERS								

REFERENCE TABLE

PCB	CODE	PORTS/TYPE
RCOU, RGLU, PCOU	11 ⁹	4 GRND/LOOP LINES
RCOU/RCOS	17 ⁹	8 LOOP CO LINES
RDDU ⁷	16 ⁹	4 DID LINES
PEMU/REMU ⁷	13 ⁹	4 TIE LINES
PEKU	21 ⁹	8 STATIONS
PEKU (EOCU)	22	8 STATIONS
PEKU w/DSS	23	8 STATIONS
PEKU (DSS, EOCU)	24	8 STATIONS
PESU	25 ⁹	6 STATIONS
PESU (OCA)	26	6 STATIONS
RDSU	27 ⁹	8 STATIONS
RDSU (OCA, DIU)	28	8 STATIONS
PSTU/RSTU	31 ⁹	8 STATIONS
PIOU, PIOUS/RSSU, PEPUS ⁵	41 ⁹	REMOTE MAINTENANCE (TTY)
PIOU/PIOUS/RSSU ⁶	42 ¹²	MIS FOR ACD (TTY) ¹²
PIOU/PIOUS/RSSU ⁶	43 ¹²	RS-232 (VM INTERFACE) (TTY) ¹²
PDKU	61 ⁹	8 STATIONS
PDKU (OCA, DIU)	62	8 STATIONS
PDKU (DSS, OCA, DIU)	64	8 STATIONS
RDTU ⁷	71 ⁹	8 T1 CHANNELS
RDTU ⁷	72	16 T1 CHANNELS
RDTU ⁷	73	24 T1 CHANNELS
RCTU	91 ⁹	NONE
RCTU ² (4-CKT RRCS)	92	NONE
RCTU ² (8-CKT RRCS)	93	NONE
RCTU ² (12-CKT RRCS)	94	NONE
NONE	00 ⁹	00
RATU ⁷ (RELEASE 2 AND ABOVE)	51 ⁹	ATTENDANT CONSOLE PCB ¹²

See notes following Program 03 record sheets.

PROGRAM 03 — FLEXIBLE PCB CABINET AND SLOT ASSIGNMENTS (continued)

NOTES:

1. See **Table 1-G** in Section 100-280-301 and notes on this page for more details when entering **Program 03** Data.
2. The RCTUA, RCTUB, or RCTUD PCB must be installed into the RCTU slot in cabinet 1. Enter slot 00 to assign PCB code 91 ~ 94 to RCTUA or RCTUB installed in RCTU slot; enter slot 01 to assign code 91 ~ 94 to RCTUD installed in the RCTU slot. The RCTUC PCB must be installed in slot R11 in cabinet 1, enter slot number 00 to assign a PCB code 91 ~ 94 to the RCTUC PCB installed in the R11.
3. The programming station (205) must be connected to circuit 6 in slot 11. The station must be a 20-button digital or electronic telephone with an LCD. A PDKU or PEKU should be installed in slot 11.
4. System power must always be cycled after running Program 03.
5. Do not install PCBs in slots S27, S28, S37, and S38, they are for future use.
6. Code 41, 42, and 43 assigns PIOUS/PIOUS RRSS TTY port as Remote Maintenance, MIS for ACD, and SMDI respectively; SMDR, Paging, Relay control, and other miscellaneous options will be active on the PIOUS or PIOUS that has the lowest number code (41, 42 or 43) in the system.
7. Install RATU and all TIE/DID line PCBs in higher numbered slots than station PCB slots (see Worksheet 2, Section 100-280-202).
8. Do not install PCBs in slots S47, S48, S57, S58, S67, and S68, they are for future use.
9. **Program 91-1** and **91-9** will automatically assign PCB codes (marked by footnote "9") if the appropriate Host PCB is installed when **Program 91** is run; **Program 91** does not assign option codes; **Program 03** must be run to assign codes for all options except RCOS (codes not marked with "9"). **Program 91-9** will erase option codes assigned with **Program 03**, **Program 91-1** does not erase option codes.
10. Program 03 should be run when adding PCBs to an existing system.
11. When using RCTUA, Slot 15 and 16 does not support OCA or DIU.
12. ACD, ACD/MIS, RS-232 Voice Mail Integration (SMDI or Toshiba Proprietary), and Attendant Console is for use with RCTUB2 or RCTUC/RCTUD2 Release 2 and above only. RCTUA does not support these features.

PROGRAM 00 — SOFTWARE CHECK/REMOTE MAINTENANCE SECURITY CODE ASSIGNMENTS

##1*2*3 - Spkr 00 Hold - Spkr [] - [] [] [] - Hold - Spkr ## Hold - Spkr ## Hold

SELECT = Select Code []
 Enter 0 to check software version.
 Enter 1 to change 1st level password.
 Enter 2 to change 2nd level password.
 Enter 8 to check software sum.
 Enter 9 to check counter.

Password Codes [] [] [] []
 Enter the 4-digit password.
 See Note 3.

Select Code	Item	Password or S/W Check Codes
0	ROM Version	= [] [] [] [] [] See Note 4.
1	1st Level Password	= [] [] [] []
2	2nd Level Password	= [] [] [] []
8	Software RAM Checksum	= [] [] [] [] [] [] [] [] See Note 6.
9	Power Cycle Counter	= [] [] [] [] [] See Note 6.

NOTES:

- See instructions in **Chapter 1, Table 1-H** to program the system with this information.
- Initialized passwords are 0000.
- The LCD responds as follows, when a selection is made:
 0 Version =
 1 Password =
 2 Password =
 8 Sum =
 9 Counter =
- This selection is not programmable. It identifies the system's software version as follows:

R [] AX [] [] - KEY X⁵
 (X = 1, 2, or 3)

Indicates RCTU Type []
 ROM Version []

Program DKT LCD DISPLAY	RCTU Type
R [A] AX	RCTUA
R [B] AX	RCTUB
R [C] AX	RCTU C/D

KEY 1 = AA: Indicates built-in Auto Attendant software.
 KEY 2 = ACD: Indicates Automatic Call Distribution software.
 KEY 3 = ACD/MIS: Indicates Automatic Call Distribution with Management Information System Software.

- RKYS feature key must be installed on RCTU PCB to allow AA, ACD, and ACD/MIS software to be operational; no special Program is necessary to activate the RKYS feature key.
- These selections are not programmable. They are for factory test purposes only. The Checksum and Counter vary as customer data is entered.

PROGRAM 01 — LOGICAL STATION PORT DISPLAY OR CHANGE

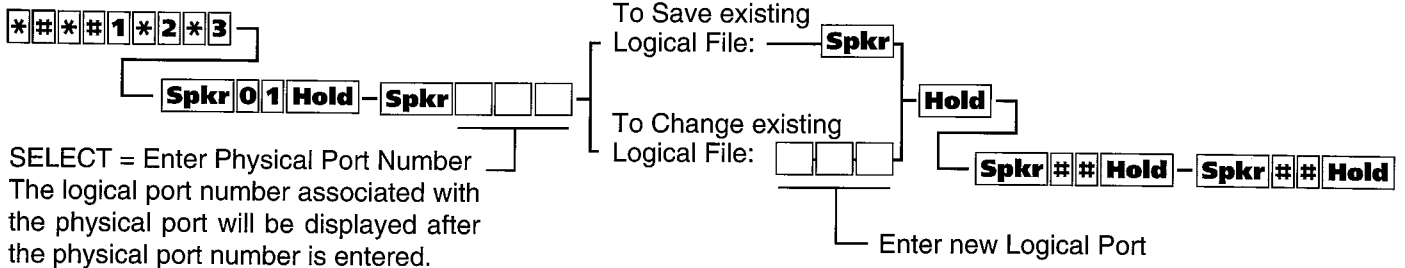

SELECT = Enter Physical Port Number
 The logical port number associated with the physical port will be displayed after the physical port number is entered.

PROGRAM 02 — PHYSICAL STATION PORT DISPLAY OR CHANGE

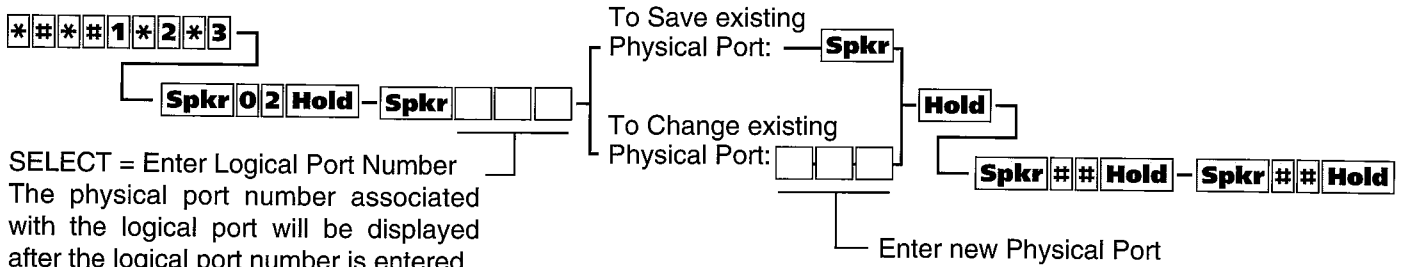

SELECT = Enter Logical Port Number
 The physical port number associated with the logical port will be displayed after the logical port number is entered.

NOTES:

1. For more information, see the instructions preceding the record sheets.
2. Record port locations on **Program 04** System Record Sheet.
3. Initialized data for **Program 01** and **02** is logical port number = physical port number. (**Program 90, 91-1, or 91-9** will initialize **Program 01** and **02.**)
4. RCTU Station Ports are: RCTUA (000~031), RCTUB (000~079), and RCTUC/D (000~239).
5. The system allows only like ports to be reassigned (see below).

Allowed:

- Digital-to-Digital Ports (PDKU-PDKU-RDSU Ports)
- Electronic-to-Electronic Ports (PEKU-PEKU-PESU Ports)
- Standard Tel to Standard Tel Ports (PSTU-RSTU-PESU-RDSU/RSTS)

Not Allowed:

- Attendant Console, DSS, BGM or Amplified Conference Ports should not be reassigned
- Door Phone Ports (004, 012, 020, 028) should not be reassigned
- TIE/DID Line Ports – should not be reassigned
- PDKU to PEKU – cannot be exchanged
- PSTU to PDKU – cannot be exchanged
- PEKU to PSTU – cannot be exchanged

PROGRAMMING PROCEDURES — RECORD SHEETS

**PROGRAM 04 — LOGICAL PORT INTERCOM NUMBER ASSIGNMENT
(LOGICAL PORTS 000 ~ 039)**

##1*2*3 - Spkr 0 4 Hold - Spkr # Hold - Spkr ## Hold - Spkr ## Hold

SELECT = Logical Port Number INT = Station Number (1 ~ 4 digits) or Key 01⁵

LOGICAL PORT	INTERCOM NUMBERS (INITIALIZED)	PHYSICAL PORTS	PHYSICAL RECORD MODULAR JACK LOCATION AND STATION TYPE	CABINET AND SLOT NUMBER
000	(200)	(000)	200	CABINET SLOT <u>1</u>
001	(201)	(001)	201	
002	(202)	(002)	202	
003	(203)	(003)	203	
004	(204)	(004)	204	
005	(205)	(005)	399 PROF. PORT	
006	(206)	(006)	206	
007	(207)	(007)	207	
008	(208)	(008)	208	
009	(209)	(009)	209	
010	(210)	(010)	210	
011	(211)	(011)	211	
012	(212)	(012)	212	
013	(213)	(013)	213	
014	(214)	(014)	214	
015	(215)	(015)	215	
016	(216)	(016)		
017	(217)	(017)		
018	(218)	(018)		
019	(219)	(019)		
020	(220)	(020)		
021	(221)	(021)		
022	(222)	(022)		
023	(223)	(023)		
024	(224)	(024)		
025	(225)	(025)		
026	(226)	(026)		
027	(227)	(027)		
028	(228)	(028)		
029	(229)	(029)		
030	(230)	(030)		
031 ¹	(231)	(031)		
032	(232)	(032)		
033	(233)	(033)		
034	(234)	(034)		
035	(235)	(035)		
036	(236)	(036)		
037	(237)	(037)		
038	(238)	(038)		
039	(239)	(039)		

1. RCTUA provides Station Ports 000-031; Ports 032-039 are reserved for special functions with RCTUA.
2. RCTUB provides Station Ports 000-079; Ports 080-089 are reserved for special functions with RCTUB.
3. RCTUC/D provides Station Ports 000-239, Ports 240-249 are reserved for special functions with RCTUC/D.
4. When users relocate telephones, logical Port numbers will move from the assigned physical port to another physical port.
5. Use KEY01 to erase Intercom numbers. Range programming 000 * 000 is OK to erase existing Intercom numbers but not to add a range of new numbers.

Low Port High Port

PROGRAMMING PROCEDURES — RECORD SHEETS

PROGRAM 04 — LOGICAL PORT INTERCOM NUMBER ASSIGNMENT
 (LOGICAL PORTS 040 ~ 079, RCTUB AND RCTU C/D ONLY) (continued)

##1*2*3 - Spkr 04 Hold - Spkr [] [] [] # [] [] [] [] Hold - Spkr ## Hold - Spkr ## Hold

SELECT = Logical Port Number

INT = Station Number (1 ~ 4 digits)

LOGICAL PORT	INTERCOM NUMBERS (INITIALIZED)	PHYSICAL PORTS	PHYSICAL RECORD MODULAR JACK LOCATION AND STATION TYPE	CABINET AND SLOT NUMBER
040	(240)	(040)		CABINET ____ SLOT ____
041	(241)	(041)		
042	(242)	(042)		
043	(243)	(043)		
044	(244)	(044)		
045	(245)	(045)		
046	(246)	(046)		
047	(247)	(047)		
048	(248)	(048)		CABINET ____ SLOT ____
049	(249)	(049)		
050	(250)	(050)		
051	(251)	(051)		
052	(252)	(052)		
053	(253)	(053)		
054	(254)	(054)		
055	(255)	(055)		
056	(256)	(056)		CABINET ____ SLOT ____
057	(257)	(057)		
058	(258)	(058)		
059	(259)	(059)		
060	(260)	(060)		
061	(261)	(061)		
062	(262)	(062)		
063	(263)	(063)		
064	(264)	(064)		CABINET ____ SLOT ____
065	(265)	(065)		
066	(266)	(066)		
067	(267)	(067)		
068	(268)	(068)		
069	(269)	(069)		
070	(270)	(070)		
071	(271)	(071)		
072	(272)	(072)		CABINET ____ SLOT ____
073	(273)	(073)		
074	(274)	(074)		
075	(275)	(075)		
076	(276)	(076)		
077	(277)	(077)		
078	(278)	(078)		
079 ²	(279)	(079)		

See notes on first page of Program 04.

PROGRAMMING PROCEDURES — RECORD SHEETS

SECTION 100-280-303

PROGRAM 04 — LOGICAL PORT INTERCOM NUMBER ASSIGNMENT
 (LOGICAL PORTS 080 ~ 119, RCTU C/D ONLY) (continued)

##*#1*2*3 - Spkr 04 Hold - Spkr [][] # [][][] Hold - Spkr ## Hold - Spkr ## Hold

SELECT = Logical Port Number

INT = Station Number (1 ~ 4 digits)

LOGICAL PORT	INTERCOM NUMBERS (INITIALIZED)	PHYSICAL PORTS	PHYSICAL RECORD MODULAR JACK LOCATION AND STATION TYPE	CABINET AND SLOT NUMBER
080	(280)	(080)		CABINET ____ SLOT ____
081	(281)	(081)		
082	(282)	(082)		
083	(283)	(083)		
084	(284)	(084)		
085	(285)	(085)		
086	(286)	(086)		
087	(287)	(087)		
088	(288)	(088)		CABINET ____ SLOT ____
089	(289)	(089)		
090	(290)	(090)		
091	(291)	(091)		
092	(292)	(092)		
093	(293)	(093)		
094	(294)	(094)		
095	(295)	(095)		
096	(296)	(096)		CABINET ____ SLOT ____
097	(297)	(097)		
098	(298)	(098)		
099	(299)	(099)		
100	(300)	(100)		
101	(301)	(101)		
102	(302)	(102)		
103	(303)	(103)		
104	(304)	(104)		CABINET ____ SLOT ____
105	(305)	(105)		
106	(306)	(106)		
107	(307)	(107)		
108	(308)	(108)		
109	(309)	(109)		
110	(310)	(110)		
111	(311)	(111)		
112	(312)	(112)		CABINET ____ SLOT ____
113	(313)	(113)		
114	(314)	(114)		
115	(315)	(115)		
116	(316)	(116)		
117	(317)	(117)		
118	(318)	(118)		
119	(319)	(119)		

See notes on first page of Program 04.

PROGRAMMING PROCEDURES — RECORD SHEETS

PROGRAM 04 — LOGICAL PORT INTERCOM NUMBER ASSIGNMENT
 (LOGICAL PORTS 120 ~ 159, RCTU C/D ONLY) (continued)

##1*2*3 - Spkr 04 Hold - Spkr [] [] [] # [] [] [] [] Hold - Spkr ## Hold - Spkr ## Hold

SELECT = Logical Port Number [] [] [] [] INT = Station Number (1 ~ 4 digits)

LOGICAL PORT	INTERCOM NUMBERS (INITIALIZED)	PHYSICAL PORTS	PHYSICAL RECORD MODULAR JACK LOCATION AND STATION TYPE	CABINET AND SLOT NUMBER
120	(320)	(120)		CABINET ____ SLOT ____
121	(321)	(121)		
122	(322)	(122)		
123	(323)	(123)		
124	(324)	(124)		
125	(325)	(125)		
126	(326)	(126)		
127	(327)	(127)		CABINET ____ SLOT ____
128	(328)	(128)		
129	(329)	(129)		
130	(330)	(130)		
131	(331)	(131)		
132	(332)	(132)		
133	(333)	(133)		
134	(334)	(134)		CABINET ____ SLOT ____
135	(335)	(135)		
136	(336)	(136)		
137	(337)	(137)		
138	(338)	(138)		
139	(339)	(139)		
140	(340)	(140)		
141	(341)	(141)		CABINET ____ SLOT ____
142	(342)	(142)		
143	(343)	(143)		
144	(344)	(144)		
145	(345)	(145)		
146	(346)	(146)		
147	(347)	(147)		
148	(348)	(148)		CABINET ____ SLOT ____
149	(349)	(149)		
150	(350)	(150)		
151	(351)	(151)		
152	(352)	(152)		
153	(353)	(153)		
154	(354)	(154)		
155	(355)	(155)		CABINET ____ SLOT ____
156	(356)	(156)		
157	(357)	(157)		
158	(358)	(158)		
159	(359)	(159)		

See notes on first page of Program 04.

PROGRAMMING PROCEDURES — RECORD SHEETS

PROGRAM 04 — LOGICAL PORT INTERCOM NUMBER ASSIGNMENT
 (LOGICAL PORTS 160 ~ 199, RCTU C/D ONLY) (continued)

##1*2*3 - Spkr 04 Hold - Spkr # # # # # Hold - Spkr # # # # # Hold - Spkr # # # # # Hold

SELECT = Logical Port Number

INT = Station Number (1 ~ 4 digits)

LOGICAL PORT	INTERCOM NUMBERS (INITIALIZED)	PHYSICAL PORTS	PHYSICAL RECORD MODULAR JACK LOCATION AND STATION TYPE	CABINET AND SLOT NUMBER
160	(360)	(160)		CABINET ____ SLOT ____
161	(361)	(161)		
162	(362)	(162)		
163	(363)	(163)		
164	(364)	(164)		
165	(365)	(165)		
166	(366)	(166)		
167	(367)	(167)		
168	(368)	(168)		CABINET ____ SLOT ____
169	(369)	(169)		
170	(370)	(170)		
171	(371)	(171)		
172	(372)	(172)		
173	(373)	(173)		
174	(374)	(174)		
175	(375)	(175)		
176	(376)	(176)		CABINET ____ SLOT ____
177	(377)	(177)		
178	(378)	(178)		
179	(379)	(179)		
180	(380)	(180)		
181	(381)	(181)		
182	(382)	(182)		
183	(383)	(183)		
184	(384)	(184)		CABINET ____ SLOT ____
185	(385)	(185)		
186	(386)	(186)		
187	(387)	(187)		
188	(388)	(188)		
189	(389)	(189)		
190	(390)	(190)		
191	(391)	(191)		
192	(392)	(192)		CABINET ____ SLOT ____
193	(393)	(193)		
194	(394)	(194)		
195	(395)	(195)		
196	(396)	(196)		
197	(397)	(197)		
198	(398)	(198)		
199	(399)	(199)		

See notes on first page of Program 04.

PROGRAMMING PROCEDURES — RECORD SHEETS

SECTION 100-280-303

**PROGRAM 04 — LOGICAL PORT INTERCOM NUMBER ASSIGNMENT
(LOGICAL PORTS 200 ~ 239, RCTU C/D ONLY) (continued)**

##*#1*2*3 - Spkr 04 Hold - Spkr [] [] [] # [] [] [] [] Hold - Spkr ## Hold - Spkr ## Hold

SELECT = Logical Port Number

INT = Station Number (1 ~ 4 digits)

LOGICAL PORT	INTERCOM NUMBERS (INITIALIZED)	PHYSICAL PORTS	PHYSICAL RECORD MODULAR JACK LOCATION AND STATION TYPE	CABINET AND SLOT NUMBER
200	(400)	(200)		CABINET ____ SLOT ____
201	(401)	(201)		
202	(402)	(202)		
203	(403)	(203)		
204	(404)	(204)		
205	(405)	(205)		
206	(406)	(206)		
207	(407)	(207)		
208	(408)	(208)		CABINET ____ SLOT ____
209	(409)	(209)		
210	(410)	(210)		
211	(411)	(211)		
212	(412)	(212)		
213	(413)	(213)		
214	(414)	(214)		
215	(415)	(215)		
216	(416)	(216)		CABINET ____ SLOT ____
217	(417)	(217)		
218	(418)	(218)		
219	(419)	(219)		
220	(420)	(220)		
221	(421)	(221)		
222	(422)	(222)		
223	(423)	(223)		
224	(424)	(224)		CABINET ____ SLOT ____
225	(425)	(225)		
226	(426)	(226)		
227	(427)	(227)		
228	(428)	(228)		
229	(429)	(229)		
230	(430)	(230)		
231	(431)	(231)		
232	(432)	(232)		CABINET ____ SLOT ____
233	(433)	(233)		
234	(434)	(234)		
235	(435)	(235)		
236	(436)	(236)		
237	(437)	(237)		
238	(438)	(238)		
239	(439)	(239) ³		

See notes on first page of Program 04.

PROGRAMMING PROCEDURES — RECORD SHEETS

SECTION 100-280-303

PROGRAM 05 — FLEXIBLE ACCESS CODE NUMBERING

###1*2*3 - Spkr - 05 Hold - Spkr - - - Hold - Spkr## Hold - Spkr## Hold

SELECT = Access Code 1 ~ 9
from the Table Below

SPECIAL DIAL = New Access Codes
See Note 5 Below.

Access Code	Features Affected (N/A = Not Affected/Cannot Change)	New Access Codes
0	Unused	
1	Voice First/Tone First (N/A)(1) Door Phones (#151 ~ #159; #161 ~ #163) IMDU Access (#19)	Station LCD Messages N/A (10 ~ 19) Station Speed Dial Set N/A (10 ~ 49)
2	Busy Override (N/A) (2) Do Not Disturb Override (N/A) (2)	Station Numbers N/A 200 ~ 439 ⁴ Off-hook Call Announce (N/A) (2)
3	Executive Override (N/A) (3) All Call Voice Page (#30) All Call Voice Page with External Spkr (#39)	External Page Zones 1 ~ 4 (#35 ~ #38) Group Page (Internal) (#311 ~ #318)
4	Automatic Callback (N/A) (4) CO Line Queuing (N/A) (4) Station Number Display (#401) Port Number Display (#402) Hold/Park (#41) Hold/Park Pickup (#42) Automatic Busy Redial (Conf + #44) Automatic Busy Redial Cancel (Int + #44) Message Waiting Answer (#408)	Emergency Call to Attendant Console (#400) Flash (#45) Account Code Input (#46) T.R. Override/T. Class Code Input (#47) BGM Over Stations ON (#481) BGM Over Stations OFF (#480) BGM Over External Speakers ON (#491) BGM Over External Speakers OFF (#490) Cancel Message Waiting at Station (#409) Access code/Speed Dial Prefix (44 or #) ⁶
5	Voluntary Account Code: Speed Dial button + 50 Call Pickup Station (#5+Station No.), Ringing CO or DID line (#59), Pick-up Telephone Page (#5+#30) Directed Pickup of CO Line on Hold (#5+#7 <input type="checkbox"/> <input type="checkbox"/> <input type="checkbox"/> = 001 ~ 144), Pick-up External Page (#5+#30 or for Zone Page #5+#35 ~ #38) Selected Group Pickup (#5+#320 ~ #339) Own Group(s) Pickup (#5+#34)	
6	Call Forward (#601, #602, #603, #604) Timed Reminder (#605 ~ #609) M/W for Voice Mail ON (#63+Station No.) M/W for Voice Mail OFF (#64+Station No.) Voice Mail ID Code Set (Call Fwd, #656) Voice Mail ID Code Set (Ans. MW, #657) LCD Message Set (#68) DKT Mute Ring Adjust (#6101) DKT Ring Level Adjust (#6102) Port Swap/Station Relocation OFF (#6281) Station Relocation ON (#6282) Logical Port Swap ON (#6283) Call Forward Ext Set or Remote Change Code (#670) Date Set (#651)	Time Set (#652) Weekday Set (#653) T.R. Override Code Change (#654, #655) System Speed Dial (N/A 600 ~ 699 RCTUB & RCTU C/D) System Speed Dial Set (N/A 60 ~ 99 - RCTUA only) LCD User Name (#621-Set, #620-Reset) DISA Security Code Change (#658) Verified Account Code Change (#659) Set LCD Messages (#68) System LCD Messages (N/A 60-99) Traveling Class Code 1 ~ 8 Change (#691 ~ #698) Logical Port Swap (#627 + Destination Intercom No.) Physical Port Calling (#629 + Physical Port No.)
7	CO Line Outgoing Calls (#7001 ~ #7144) ⁶	Message Waiting Set/Cancel (N/A) (7)/(77)
8	CO Group Outgoing Calls (801 ~ 816)	
9	Least Cost Routing or CO Group (9)	

NOTES:

1. Be sure access code changes do not conflict with existing access code or station numbering schemes. Refer to **Program 04** – Port/Station Number Assignment.
2. To insert a blank, press programming LED/Button 01.
3. If access codes are being changed to a number that is currently assigned, change the currently assigned code to an unused code first. In the initialized state, the only unused code is zero (0).
4. The initialized station number sequence of 200 ~ 439 may not be globally changed through Program 05. Make changes through **Program 04**.
5. The first digit of Access codes can be replaced by 2 digits. Standard Access codes are shown above for reference.
6. To store a CO line or feature access code in Speed Dial memory from telephones without the **Speed Dial (SDS)** and **Redial (RDL)** buttons, enter 44+7XXX instead of #+7XXX.

PROGRAM 09 — AUTO ATTENDANT PROMPT/STATION ASSIGNMENTS

##1*2*3 - Spkr - 09 Hold - Spkr - - - - Hold - Spkr## Hold - Spkr## Hold

SELECT = PROMPT
 Select prompt offered to caller.
 First or second digit.
 (See Notes 1 and 2).

AUTO ATT DIAL = (1 ~ 4 DIGITS)
 Select the station intercom numbers which
 will receive Auto Attendant calls.
 Could be * if establishing the first digit.
 (See Notes 1, 2 and 6).

Dialed Digit (Menu Prompts)	Station (Intercom) Number	Department, Division, Etc.
0		
1		
2 (Note 5)		
3 (Note 5)		
4 (Note 5)		
5		
6		
7		
8		
9		

NOTES:

1. To enter one-digit dialing prompts along with their destination station numbers:
 - 1) Enter **Program 09**, and then see "SELECT" on the LCD.
 - 2) Press the desired digit (prompt), and then see "AUTO ATT DIAL" on the LCD.
 - 3) Enter the destination station Intercom (not Port number) number or ACD group (per Note 6) associated with the prompts and then the **Hold (HOLD)** button.
 - 4) Press **Spkr** and repeat Steps 2 and 3 for more prompt-station entries.
2. To enter two digit dialing prompts along with their destination station numbers:
 - 1) Enter **Program 09**, and then see "SELECT" on the LCD.
 - 2) Press the desired leading digit, and then see "AUTO ATT DIAL" on the LCD.
 - 3) Press * and then the **Hold (HOLD)** button. The first digit will now be set, and "DATA PROGRAMED" will again appear on the LCD.
 - 4) Press **Spkr** and press a second digit, and then see "AUTO ATT DIAL" on the LCD.
 - 5) Enter the destination station Intercom number assigned to the two-digit prompt and then the **Hold (HOLD)** button.
 - 6) To complete more prompt-station entries, repeat Steps 4 and 5.
3. When transmission and DTMF levels are lower than normal or when the digital announcement voice frequencies match DTMF digital frequencies (talk-off), Auto Attendant efficiency may be improved with two-digit dialing options, instead of one-digit dialing options.
4. Press key LED 01 to delete data.
5. Don't use digits 2, 3, and 4, because these numbers conflict with the default station (intercom) numbers of the system.
6. To assign a Digit (Menu prompt) to an ACD Group, enter # 4 X X in place of the Station (Intercom) Number at "AUTO ATT DIAL" LCD programming prompt, where XX is the ACD Group number 01~16.

PROGRAMMING PROCEDURES — RECORD SHEETS

SECTION 100-280-303

PROGRAM *09 — DID DIGIT TRANSLATION (LOGICAL PORTS 000 ~ 119)

###1*2*3 - Spkr * 0 9 Hold - Spkr [] [] [] # [] [] [] Hold - Spkr ## Hold - Spkr ## Hold

SELECT = Logical Port Number³ []

DIAL = DID Extension Number (1 ~ 4 Digits)

LOGICAL PORT	DID EXTENSION NUMBER (1 ~ 4 DIGITS) INITIALIZED
000	(200)
001	(201)
002	(202)
003	(203)
004	(204)
005	(205)
006	(206)
007	(207)
008	(208)
009	(209)
010	(210)
011	(211)
012	(212)
013	(213)
014	(214)
015	(215)
016	(216)
017	(217)
018	(218)
019	(219)
020	(220)
021	(221)
022	(222)
023	(223)
024	(224)
025	(225)
026	(226)
027	(227)
028	(228)
029	(229)
030	(230)
031	(231)
032	(232)
033	(233)
034	(234)
035	(235)
036	(236)
037	(237)
038	(238)
039	(239)

LOGICAL PORT	DID EXTENSION NUMBER (1 ~ 4 DIGITS) INITIALIZED
040	(240)
041	(241)
042	(242)
043	(243)
044	(244)
045	(245)
046	(246)
047	(247)
048	(248)
049	(249)
050	(250)
051	(251)
052	(252)
053	(253)
054	(254)
055	(255)
056	(256)
057	(257)
058	(258)
059	(259)
060	(260)
061	(261)
062	(262)
063	(263)
064	(264)
065	(265)
066	(266)
067	(267)
068	(268)
069	(269)
070	(270)
071	(271)
072	(272)
073	(273)
074	(274)
075	(275)
076	(276)
077	(277)
078	(278)
079	(279)

LOGICAL PORT	DID EXTENSION NUMBER (1 ~ 4 DIGITS) INITIALIZED
080	(280)
081	(281)
082	(282)
083	(283)
084	(284)
085	(285)
086	(286)
087	(287)
088	(288)
089	(289)
090	(290)
091	(291)
092	(292)
093	(293)
094	(294)
095	(295)
096	(296)
097	(297)
098	(298)
099	(299)
100	(300)
101	(301)
102	(302)
103	(303)
104	(304)
105	(305)
106	(306)
107	(307)
108	(308)
109	(309)
110	(310)
111	(311)
112	(312)
113	(313)
114	(314)
115	(315)
116	(316)
117	(317)
118	(318)
119	(319)

NOTE:

1. IMDU modem DID extension numbers are assigned to Port 035 (RCTUA), Port 085 (RCTUB), and Port 245 (RCTUC/D)
2. Initialized Data is Port 000=200, Port 001=201....Port 239=439.
3. To range program: Enter port range X X X * Y Y Y, then set DIAL to the first extension number in the range and press Hold. The extension numbers will automatically be numbered in successive order (XXX = low port, YYY = high port). Do not press **##** after entering a port range.
4. Press Key 01, to enter Blank/erase Extension numbers.

PROGRAMMING PROCEDURES — RECORD SHEETS

##1*2*3 - Spkr * 0 9 Hold - Spkr [] [] [] # [] [] [] [] Hold - Spkr ## Hold - Spkr ## Hold

SELECT = Logical Port Number

DIAL = DID Extension Number (1 ~ 4 Digits)

LOGICAL PORT	DID EXTENSION NUMBER (1 ~ 4 DIGITS) INITIALIZED
120	(320)
121	(321)
122	(322)
123	(323)
124	(324)
125	(325)
126	(326)
127	(327)
128	(328)
129	(329)
130	(330)
131	(331)
132	(332)
133	(333)
134	(334)
135	(335)
136	(336)
137	(337)
138	(338)
139	(339)
140	(340)
141	(341)
142	(342)
143	(343)
144	(344)
145	(345)
146	(346)
147	(347)
148	(348)
149	(349)
150	(350)
151	(351)
152	(352)
153	(353)
154	(354)
155	(355)
156	(356)
157	(357)
158	(358)
159	(359)

LOGICAL PORT	DID EXTENSION NUMBER (1 ~ 4 DIGITS) INITIALIZED
160	(360)
161	(361)
162	(362)
163	(363)
164	(364)
165	(365)
166	(366)
167	(367)
168	(368)
169	(369)
170	(370)
171	(371)
172	(372)
173	(373)
174	(374)
175	(375)
176	(376)
177	(377)
178	(378)
179	(379)
180	(380)
181	(381)
182	(382)
183	(383)
184	(384)
185	(385)
186	(386)
187	(387)
188	(388)
189	(389)
190	(390)
191	(391)
192	(392)
193	(393)
194	(394)
195	(395)
196	(396)
197	(397)
198	(398)
199	(399)

LOGICAL PORT	DID EXTENSION NUMBER (1 ~ 4 DIGITS) INITIALIZED
200	(400)
201	(401)
202	(402)
203	(403)
204	(404)
205	(405)
206	(406)
207	(407)
208	(408)
209	(409)
210	(410)
211	(411)
212	(412)
213	(413)
214	(414)
215	(415)
216	(416)
217	(417)
218	(418)
219	(419)
220	(420)
221	(421)
222	(422)
223	(423)
224	(424)
225	(425)
226	(426)
227	(427)
228	(428)
229	(429)
230	(430)
231	(431)
232	(432)
233	(433)
234	(434)
235	(435)
236	(436)
237	(437)
238	(438)
239	(439)
245	

NOTE:
See notes on previous page.

PROGRAM 10-1 — SYSTEM ASSIGNMENTS, PART 1 OF 3

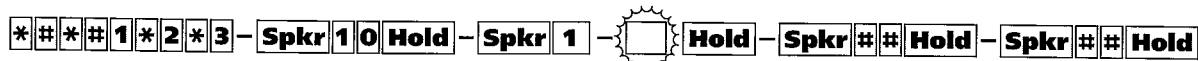

SELECT = 1

Buttons/LEDs
Light LEDs as described in
the table below

Key/LED	X	LED On	LED Off
20	X ²	Two-CO line Conference/Allowed ⁵	Not Allowed
19	X ²	Conference/Allowed	Not Allowed
18	X ²	Ring Detect Time - Normal	Ring Detect Time – Short Rings
17		Intercom Volume PAD (-8 dB)	No Intercom PAD
16		–	–
15		–	–
14		–	–
13		–	–
12		ABR Cycles/10 times	15 times
11	X	ABR Redial time/30 sec.	1 min.
10		System Speed Dial Override,Toll Restriction	Restricted
09	X ²	Exclusive Hold/Allowed	Not Allowed
08	X ²	Alternate Point Answer	Transfer Privacy
07 ⁴	X ²	Ring Transfer of CO Line Allowed	Not Allowed
06 ⁵		CO line Repeat Ringing	Standard Ring
05		Incoming Call Abandon/8 sec.	6 sec.
04 ²		CO line DTMF Signal Time/160 msec.	80 msec. ³
03		DP Make Ratio/33%	40%
02 ⁷	X	0.45 or 1.5 sec. per Program 42-0	CO line re-seize guard time 0.45
01		Tone First (from DKTs and EKTs)	Voice First (DKTs from EKTs)

NOTES:

1. For more information, see the instructions preceding the record sheets.
2. Initialized data lights LEDs 07, 08, 09, 18, 19 and 20.
3. LED 04 DTMF Signal Time applies to manual and speed dial tones sent out of the system via CO lines. This applies when dialing from any Toshiba telephone, including the 2000-series Digital Telephone. LED 04 does not apply to Call Forward or Voice Mail ID DTMF tones sent to voice mail ports. (See Program 10-2, LED 06, for tones sent to Voice Mail ports.)
4. If Ring Transfer is allowed, set Ring Transfer Recall time in Program 37; if ring transfer is not allowed (LED 07 off), the station will recall immediately if transfer is attempted.
5. Standard ring pattern is 1 sec. on, 3 sec. off.
6. Two-CO line Conference must be allowed for DISA and CF-EXT operation.
7. CO line guard time is the time interval the system requires to release a CO line and re-seize it. If LED 02 is off, all lines are set with 0.45 second guard time; if LED is on, guard time is 0.45 or 1.5 seconds per Program 42-0.

PROGRAM 10-2 — SYSTEM ASSIGNMENTS (PART 2 OF 3)

##1*2*3 - Spkr 1 0 Hold - Spkr 2  Hold - Spkr ## Hold - Spkr ## Hold

SELECT = 2

Buttons/LEDs

Light LEDs as defined by the table below.

ALL LEDs with an "X" should be lit when you finish

BUTTON/ LED	X	LED On	LED Off
20		Single Tone Return When Dialing	DTMF/No DTMF Per Prog 10-2, LED 11
19 ⁸		External Conference Amp Connected to PEKU	No External Amplifier Connected
18 ⁸		External Conference Amp Connected to PEKU	No External Amplifier Connected
17		"TRNS" Soft Key—Immediate	"TRNS" Soft Key—Normal
16	X	Executive Override Warning Tone/ON	Executive Override Warning Tone/OFF
15 ⁶	X	External Page included with All Call Page	Not Included
14	X	Privacy Override/Attendant/Supervised Loop Warning Tone/ON	Privacy/Attendant Supervised Loop Override Warning Tone/OFF
13		Send Auto Callback Camp-on Tone ²	No Callback Tone
12		CO Line 3 min Beep Tone	No Beep Tone
11		No DTMF Tone Return When Dialing ⁶	DTMF Tone Return When Dialing
10 ³		BGM connected to PESU, Circuit 8 ⁷	EKT connected to PESU, CKT 8
09 ³		BGM connected to PEKU, Circuit 3 ⁷	EKT connected to PEKU, CKT 3
08		Elapsed Time Display 1 min. After Access or Answer a CO line	Elapsed Time Display 15 sec. After Access or Answer a CO Line
07 ⁴		Standard Tel. CO Ring per Prog. 10-1, LED 06	Standard Tel. CO Ring Distinctive
06		VM ID Code DTMF Signal Time 80 ms	160 ms
05			
04 ⁹		MW cancel from VM; RS-232 or dial # 6 4 & Station No.	MW cancel from VM: Automatic When Answer
03		Ringing Modes/3	Ringing Modes/2
02	X	Hunt/C.F. override from DSS console's phone	Hunt/C.F. override from DSS console
01		Tone First (from DSS Console)	Voice First (from DSS Console)

NOTES:

1. Initialized data lights LEDs 02, 14, 15 and 16.
2. Called party receives notification tone when calling party activates ACB.
3. BGM connected to the PEKU or PESU will be sent to electronic and digital telephone speakers and external page (optional). To assign the BGM PCB slot number, see **Program 19-1**.
4. The ring pattern for standard telephone, distinctive ring on incoming trunk calls is: 0.2 sec. on/0.4 sec. off, 0.2 sec. on/3.4 sec. off; intercom ring is always 1 sec. on, 3 sec. off. This does not apply to VM Ports (**Program 31**, LED 17 on) which are always standard ring.
5. External speakers and all electronic and digital telephones are paged by dialing: **Intercom (INT) # 3 9**. The **All Call Page (AC)** button is used to page all digital and electronic telephones only; external speakers are not included when using the button.
6. Deletes DTMF tones returned to digital and electronic telephones when dialing from dialpad or speed dialing; also deletes auto dial digits from callers that are call forwarded to voice mail. This does not affect the actual DTMF tones sent out to trunks or voice mail devices.
7. PESU/PEKU can be in any universal slot assigned in **Program 19-1**.
8. **Important:** LED 18 and 19 should be OFF unless external amplifiers are used for Two-CO line/Station Conference (see **Program 10-3**). If LED 18 and 19 are ON, the station may be unbalanced and receive HUM if external amplifier with Auto-Gain-Control is not connected. It is recommended to test conference with LED 18 and 19 ON; if there is no HUM noise, Keep LED 18 and 19 ON.
9. LED 04 should be on for DTMF or RS-232 VM interation – also see **Program 31**.

PROGRAM 10-3 — SYSTEM ASSIGNMENTS (PART 3 OF 3)

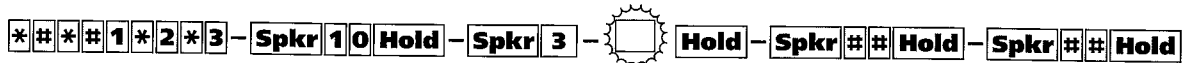

SELECT = 3

Buttons/LEDs

Light LEDs as defined by the table below.

ALL LEDs with an "X" should be lit when you finish.

Button/ LED	X	LED ON	LED OFF
20			
19	X	Speed Dial Entry Timeout—3 Minutes	Speed Dial Entry Timeout—1 Minute
18		Auto Attd: Normal Ringing Pattern After Camp-On	Auto Attd: Back to Announcement After Camp-On
17 ⁶		Auto Attd: Ring Before Disconnect Time	Auto Attd: Ring Before Disconnect Time
16 ⁶		Auto Attd: Ring Before Disconnect Time	Auto Attd: Ring Before Disconnect Time
15		Auto Attd: Sends MOH to Caller	Auto Attd: Sends RBT to Caller
14 ⁸		SMDI-Bellcore Standard VM Interface, per LED 09 below	Toshiba Proprietary – RS232 VM Interface
13 ⁷		SMDI-Station Number Digit Length (HEX-8)	SMDI-Station Number Digit Length (HEX-0)
12 ⁷		SMDI-Station Number Digit Length (HEX-4)	SMDI-Station Number Digit Length (HEX-0)
11 ⁷		SMDI-Station Number Digit Length (HEX-2)	SMDI-Station Number Digit Length (HEX-0)
10 ⁷		SMDI-Station Number Digit Length (HEX-1)	SMDI-Station Number Digit Length (HEX-0)
09 ⁸		Bellcore Standard 1985 Version (1-space)	Bellcore Standard 1991 Version (2-spaces)
08			
07			
06			
05			
04 ⁴		PESU/PEKU Ports 33, 34 — Amp. 4 Connected	Ports 33, 34 — Stations Connected
03		PESU/PEKU Ports 25, 26 — Amp. 3 Connected	Ports 25, 26 — Stations Connected
02		PESU/PEKU Ports 17, 18 — Amp. 2 Connected	Ports 17, 18 — Stations Connected
01		PESU/PEKU Ports 09, 10 — Amp. 1 Connected	Ports 09, 10 — Stations Connected

NOTES:

1. Initialized data: LEDs 11 and 13 ON, all other LEDs OFF.
2. See Section 100-280-207, for connecting up to four two-way amplifiers for use on tandem, DISA, External Call Forward, and conference telephone calls.
3. **Important:** Only enable the PEKU and PESU ports that are actually connected to amplifiers. Do not install TIE/DID lines on RATU PCB in Slots with lower slot numbers than amplified conference PEKU slots.
4. Amplifiers are switched into two-CO line calls automatically, one amplifier for each call, starting from the lowest ports enabled to the highest. Skipping ports is allowed. Two-CO line calls established after all amplifiers are in use will not be amplified. RCTUB and C/D allows up to 4 Amplifiers, RCTUA allows up to 3 Amplifiers.
5. See Program 10-2, LED 18 and 19; Program 10-1, LEDs 19 and 20; and Program 15-5 for more information regarding Two-CO line conference/tandem.
6. The time the Auto Attendant will ring stations (per Program 81, 84, 87) after a loop start line caller does not dial and/or a ringing station does not answer. Set ring disconnect time as shown above. If a call is not answered before ring disconnect time period time-out, the call will disconnect. This is to prevent loop start lines from being locked-up when there is no CPC supervision from the central office after the outside caller hangs up.
7. Set LED 10-13 ON so that their HEX values add up to the Voice Mail station digit length for SMDI VM interface. (Example: For VP100 SMDI interface, set LEDs 10, 11, and 12 on for 7 digits (1+2+4=7). LEDs 10-13 should be off for Toshiba proprietary VM interface.
8. Toshiba Proprietary and SMDI is available with RCTUB2 or RCTUC/RCTUD2 Release 2 and above only.

Ring Time	LED 16	LED 17
40 sec	OFF	OFF
120 sec	OFF	ON
240 sec	ON	OFF

PROGRAMMING PROCEDURES — RECORD SHEETS

PROGRAM 12 — SYSTEM ASSIGNMENTS — BASIC TIMING

##*#1*2*3 - Spkr 1 2 Hold - Spkr [] - [] - Hold - Spkr ## Hold - Spkr ## Hold

SELECT = 3 ~ 9
Enter program code,
3 ~ 9, from table below.

SELECT CODE = Enter required
code for the time listed in the
table below. See Note 3.

Program Code	Function	Code	Time	Required Code
3 ⁶	Pause Timing (Speed Dial)	1	1.5 sec.	
		2	3.0 sec.	
4 ⁴	Flash Timing ³	1	0.5 sec.	1
		2	2.0 sec.	
		4	0.2 sec. ⁵	
5	Pause After Flash (Voice Path Delay)	0	no pause	
		1	1.5 sec.	
		2	3 sec.	
8 ⁷	External Call Forward and DISA Disconnect Timer for Loop Start Lines	1	4 minute disconnect	
		2	10 minute disconnect	
		3	20 minute disconnect	
9	RRCS Inter-digital Release Time (Standard Phone)	1	1 sec.	
		through 9	through 9 sec.	

NOTES:

1. For more information, see the instructions preceding the record sheets.
2. Initialized data programs timing as follows: Code 3 = 1, Code 4 = 2, Code 5 = 0, Code 8 = 1, Code 9 = 4.
3. When programming Code 8 and 9, the LCD responds with LINE TIME = instead of SELECT CODE =.
4. The duration of time the RCOU/RCOS or PCOU circuit opens Tip & Ring when the **Flash (FLASH)** or **MW/FL** button is pressed, or hookflash code **Cnf/Trn (CONF/TRANS) # 4 5** is dialed.
5. This timing is not used in the United States.
6. This timing applies to voice calls originated from telephones and data calls originated by system Data Interface Units.
7. DISA or Call Forward External calls made on loop start lines will be automatically disconnected when the DISA/CF-EXT timer expires. Callers will hear a warning tone and can Dial "0" to reset this timer repeatedly. This is to prevent loop start line lock up if no CPC disconnect signal is provided by the central office when outside caller hangs up.

PROGRAM 13 — DEFINING THE MESSAGE CENTER

##1*2*3 - Spkr 1 3 Hold - Spkr 1 - Hold - Spkr ## Hold - Spkr ## Hold

SELECT = 1

PORT = Port Number
Enter the port number of the station to be defined as the Message Center.

Port Number ⁷

NOTES:

1. For more information, see the instructions preceding the record sheets.
2. Any electronic or digital telephone may receive (and store) up to 3 message waiting indications from any other electronic or digital telephone. A fourth message waiting indication may be set by the Message Center electronic or digital telephone only.
3. The Message Center is allowed to perform "Message Waiting," even if disallowed on all other stations.
4. Initialized data = no port assigned.
5. The message center feature should be assigned to the customer's main answering position: a station or the lowest port (in VM group) of the customer's voice mail device (see **Program 31** for VM group port assignment), whichever the customer specifies.
6. When using RS-232 (SMDI or Toshiba Proprietary) voice mail interface, all stations must also be assigned to the message center port in **Program *32**.
7. For RS-232 (SMDI or Toshiba Proprietary) and/or In Band (DTMF) Voice mail integration, enable the RSTU (or equivalent) port connected to the lowest VM port as the message center in **Program 13** and ***32**.

PROGRAMMING PROCEDURES — RECORD SHEETS

PROGRAM 15 — ASSIGNING DP/DTMF, TENANT SERVICE TO INDIVIDUAL CO LINES

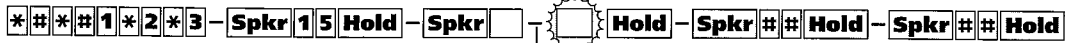

SELECT = Program Code

Buttons/LEDs = CO line

Press: **Scroll** to advance or **Page** to go back²

Specify CO line by setting LEDs as defined by the table below. All LEDs with an "X" should be lit when finished. See Note 3 to turn line ranges ON/OFF.

Copy this page for more lines.

Check off the line range covered by this table.

Range	001 ~ 020	021 ~ 040	041 ~ 060	061 ~ 080	081 ~ 100	101 ~ 120	121 ~ 140	141 ~ 144
-------	-----------	-----------	-----------	-----------	-----------	-----------	-----------	-----------

Program Code	Program	LED Status		LINE																					
		ON	OFF	01	02	03	04	05	06	07	08	09	10	11	12	13	14	15	16	17	18	19	20	LED	
0	CPC on AR VM Calls ⁴ and voice calls	Detect	Ignore																						
1	CO/DID/TIE Line Signal ⁶	DP	DTMF																						
2	CO/DID/TIE Dial Pulse Rate (Pulse per sec.)	20 PPS	10 PPS																						
3	AR Hold ^{4,7}	Detect	Ignore																						
4	AR Timing ⁴	Crossbar 95 msec.	ESS (Electronic) 450 msec.																						
5	Tandem CO Line Connection with Station Dropout	Equipped	Not Equipped	X																					
7	Forced Account Code	Equipped	Not Equipped																						
8	Operation After Flash	No RRCS after flash	RRCS after flash																						

Check off the line range covered by this table.

Range	001 ~ 020	021 ~ 040	041 ~ 060	061 ~ 080	081 ~ 100	101 ~ 120	121 ~ 140	141 ~ 144
-------	-----------	-----------	-----------	-----------	-----------	-----------	-----------	-----------

Program Code	Program	LED Status		LINE																					
		ON	OFF	01	02	03	04	05	06	07	08	09	10	11	12	13	14	15	16	17	18	19	20	LED	
0	CPC on AR VM Calls ⁴ and voice calls	Detect	Ignore																						
1	CO/DID/TIE Line Signal ⁶	DP	DTMF																						
2	CO/DID/TIE Dial Pulse Rate (Pulse per sec.)	20 PPS	10 PPS																						
3	AR Hold ^{4,7}	Detect	Ignore																						
4	AR Timing ⁴	Crossbar 95 msec.	ESS (Electronic) 450 msec.																						
5	Tandem CO Line Connection with Station Dropout	Equipped	Not Equipped																						
7	Forced Account Code	Equipped	Not Equipped																						
8	Operation After Flash	No RRCS after flash	RRCS after flash																						

NOTES:

1. Initialized data is all LEDs OFF.
2. To advance the CO line range, press the **Scroll** button beneath the LCD. Press the **Page** button for a lower range.
3. To turn all CO LEDs on or off, after the Program code is entered, press the Vol-up (all LEDs on) or Vol-down (all LEDs off). To check a particular CO line, after the Program code is entered, press Mode and enter the CO line number, then use the **Ⓜ** key to display and advance.
4. The Automatic Release (AR) signal is called Calling Party Control (CPC) or Supervised Loop Control. This signal consists of a momentary open of the loop start CO line provided by some Central Office (CO)—the duration of the open depends on the CO. If a CO line is programmed (**Programs 15-0** and **15-3**) to detect the AR signal, the DK system will drop the line when the CO sends the signal (typically 1 ~ 15 seconds after the outside party hangs up). The systems will send D Tone to voice mail (VM) ports to drop the ports when AR is detected. The STRATA DK system will disconnect a loop start CO line voice call anytime that the AR signal is detected and the CO line has **Programs 15-0** and **15-3** enabled. "CO LINE HANG UP" will display on the station's LCD when this happens.
5. (Tandem CO line) must be equipped for all CO lines that must provide 2 CO line conference, DISA, or CF-External.
6. See **Program 30**, LED 11, for TIE/DID Dial Pulse operation.
7. If loop start lines are programmed to detect the AR-Hold signal, they will not remain on the Attendant Console loop keys when the Attendant Console sets up trunk-to-trunk connection. If programmed to ignore AR-Hold, they will remain on Attendant, Hold loop keys. Enable AR-Hold detect on loop start lines only after testing that the CO sends the AR-Hold signal.

PROGRAMMING PROCEDURES — RECORD SHEETS

PROGRAM *15 — CO LINE TENANT ASSIGNMENTS

##1*2*3 - Spkr *15 Hold - Spkr [] [] [] # [] Hold - Spkr ## Hold - Spkr ## Hold

SELECT = CO Line Number (001 ~ 144)

TENANT = Assign the CO line to a tenant (1 ~ 4).

CO Line Range: [] [] [] * [] [] []

CO LINE	TENANT GROUP			
	1	2	3	4
001				
002				
003				
004				
005				
006				
007				
008				
009				
010				
011				
012				
013				
014				
015				
016				
017				
018				
019				
020				
021				
022				
023				
024				
025				
026				
027				
028				
029				
030				
031				
032				
033				
034				
035				
036				
037				
038				
039				
040				
041				
042				
043				
044				
045				
046				
047				
048				
049				
050				

CO LINE	TENANT GROUP			
	1	2	3	4
051				
052				
053				
054				
055				
056				
057				
058				
059				
060				
061				
062				
063				
064				
065				
066				
067				
068				
069				
070				
071				
072				
073				
074				
075				
076				
077				
078				
079				
080				
081				
082				
083				
084				
085				
086				
087				
088				
089				
090				
091				
092				
093				
094				
095				
096				
097				
098				
099				
100				

CO LINE	TENANT GROUP			
	1	2	3	4
101				
102				
103				
104				
105				
106				
107				
108				
109				
110				
111				
112				
113				
114				
115				
116				
117				
118				
119				
120				
121				
122				
123				
124				
125				
126				
127				
128				
129				
130				
131				
132				
133				
134				
135				
136				
137				
138				
139				
140				
141				
142				
143				
144				

NOTE:

Initialized all CO lines assigned to Tenant 1.

PROGRAMMING PROCEDURES — RECORD SHEETS

SECTION 100-280-303

PROGRAM 16 — ASSIGN CO LINE GROUPS (DIAL 9 OR 801 ~ 816)

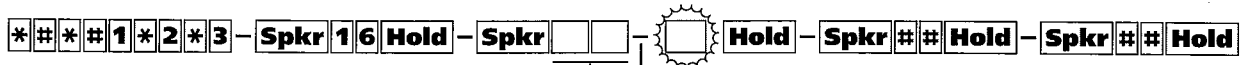

SELECT = CO Line Group _____
 Only enter the last two digits of the trunk group (01 ~ 16) to be defined, or enter 00 for Dial 9 group.

Buttons/LEDs
 Specify which trunks are assigned to the group by setting LEDs as defined by the table below. All LEDs with an "X" should be lit when finished.
 See Note 2 to turn line ranges (ON/OFF).

Press: **Scroll** to advance or **Page** to go back²

Check off the CO line range covered by this table.

Range	001 ~ 020	021 ~ 040	041 ~ 060	061 ~ 080	081 ~ 100	101 ~ 120	121 ~ 140	141 ~ 144
-------	-----------	-----------	-----------	-----------	-----------	-----------	-----------	-----------

Copy this page for more trunks

LED	Line No.	CO Line Groups																
		801	802	803	804	805	806	807	808	809	810	811	812	813	814	815	816	Dial 9(00)
20																		
19																		
18																		
17																		
16																		
15																		
14																		
13																		
12																		
11																		
10																		
09																		
08																		
07																		
06																		
05																		
04																		
03																		
02																		
01																		
20																		
19																		
18																		
17																		
16																		
15																		
14																		
13																		
12																		
11																		
10																		
09			X															
08			X															
07			X															
06			X															
05			X															
04			X															
03			X															
02			X															
01			X															

NOTES:

1. Initialized data assigns all CO lines to the Dial 9 group.
2. To turn all CO LEDs on or off, after the Line Group is entered, press the Vol-up (all LEDs on) or Vol-down (all LEDs off). To check a particular CO line, after the Line Group is entered, press and enter the CO line number, then use the **##** key to display and advance.
3. To advance the CO line range, press the Scroll button beneath the LCD. Press the Page button for a lower range.
4. RCTU C/D provides 16 CO line Groups, RCTUA and RCTUB provide 8 CO line Groups

PROGRAMMING PROCEDURES — RECORD SHEETS

SECTION 100-280-303

PROGRAM *17— DID INTERCEPT PORT NUMBER (WHEN CALLER DIALS VACANT OR WRONG NUMBER)

###1*2*3 - Spkr *17 Hold - Spkr [][] # [][] Hold - Spkr ## Hold - Spkr ## Hold

SELECT = DID-Line Number (001 ~ 144)

HUNT TO = Enter Intercept Port No.
(Press Key 01) to enter blanks

To enter DID Line Range: [][][] * [][][]

Low DID Line

High DID Line

DID LINE NUMBER	INTERCEPT PORT NUMBER
001	
002	
003	
004	
005	
006	
007	
008	
009	
010	
011	
012	
013	
014	
015	
016	
017	
018	
019	
020	
021	
022	
023	
024	
025	
026	
027	
028	
029	
030	
031	
032	
033	
034	
035	
036	
037	
038	
039	
040	
041	
042	
043	
044	
045	
046	
047	
048	

DID LINE NUMBER	INTERCEPT PORT NUMBER
049	
050	
051	
052	
053	
054	
055	
056	
057	
058	
059	
060	
061	
062	
063	
064	
065	
066	
067	
068	
069	
070	
071	
072	
073	
074	
075	
076	
077	
078	
079	
080	
081	
082	
083	
084	
085	
086	
087	
088	
089	
090	
091	
092	
093	
094	
095	
096	

DID LINE NUMBER	INTERCEPT PORT NUMBER
097	
098	
099	
100	
101	
102	
103	
104	
105	
106	
107	
108	
109	
110	
111	
112	
113	
114	
115	
116	
117	
118	
119	
120	
121	
122	
123	
124	
125	
126	
127	
128	
129	
130	
131	
132	
133	
134	
135	
136	
137	
138	
139	
140	
141	
142	
143	
144	

NOTES:

1. Initialized data = blanks (no data).
2. Use Key 01 to reset to non-intercept (re-order tone).

PROGRAM 19 — ALTERNATE BACKGROUND MUSIC SLOT IDENTIFICATION

##1*2*3 - Spkr 1 9 Hold - Spkr 1 - Hold - Turn System Power OFF (5 sec) then ON

SELECT = 1

Enter the Slot Number (11 ~ 66)

NOTES:

1. For more information, see the instructions preceding the record sheets.
 2. If PEKU, the BGM source must be wired to Circuit 3 (**Program 10-2**).
 3. If PESU, the BGM source must be wired to Circuit 8 (**Program 10-2**).
 4. If RSTU, RDSU, or PSTU, the BGM source must be wired to Circuit 2. An isolation transformer may be required if connecting the source to a RSTU, RDSU, or PSTU. See Section **100-280-207** for isolation transformer installation instructions.
 5. LED 09 (PEKU) or LED 10 (PESU) in **Program 10-2** must be ON to enable the BGM connection; **Program 10-2**, LED 09 and 10 must be OFF when connecting BGM to RSTU, RDSU or PSTU.
 6. BGM cannot be connected to the PDKU.
- Important** 7. If alternate BGM source is not connected to a station circuit, assign slot 11 as data in **Program 19-1**. This will ensure that there is not a misoperation of PSTU/RSTU/RDSU ports caused by corrupted data in RAM.

PROGRAM 20 — DIGITAL DATA PORT CONFIGURATION

##*#1*2*3 - Spkr 2 0 Hold - Spkr #  Hold - Spkr ## Hold - Spkr ## Hold

Select = PDKU/PDSU Port Number that is connected to PDIU-DS or to DKT with PDIU-DI.

LEDs 01 ~ 06 defines data port type; LEDs 17 ~ 20 assigns data port to security group.

Copy this page if more than three DIUs are installed.

PDKU/RDSU Port Number

PDKU/RDSU Port Number

PDKU/RDSU Port Number

LED	X	LED ON	LED OFF
20		Data Security Group 4	Not Included
19		Data Security Group 2	Not Included
18		Data Security Group 3	Not Included
17		Data Security Group 1	Not Included
16			
15			
14			
13			
12			
11			
10			
09			
08			
07			
06		DTR Pulse with Data Release	No DTR Pulse
05		Auto Pause ² Behind PBX	No Auto Pause
04		PDIU-DS Connected	PDIU-DI Connected
03		PDIU-DS to Modem Connection	PDIU-DS to other type DCE or DTE
02		AT Commands and Result Codes	AT Commands Only
01		DIU Connected	No DIU Connected

LED	X	LED ON	LED OFF
20		Data Security Group 4	Not Included
19		Data Security Group 2	Not Included
18		Data Security Group 3	Not Included
17		Data Security Group 1	Not Included
16			
15			
14			
13			
12			
11			
10			
09			
08			
07			
06		DTR Pulse with Data Release	No DTR Pulse
05		Auto Pause ² Behind PBX	No Auto Pause
04		DIU-DS Connected	DIU-DI Connected
03		DIU-DS to Modem Connection	DIU-DS to other type DCE or DTE
02		AT Commands and Result Codes	AT DIAL Command Only
01		DIU Connected	No DIU Connected

LED	X	LED ON	LED OFF
20		Data Security Group 4	Not Included
19		Data Security Group 2	Not Included
18		Data Security Group 3	Not Included
17		Data Security Group 1	Not Included
16			
15			
14			
13			
12			
11			
10			
09			
08			
07			
06		DTR Pulse with Data Release	No DTR Pulse
05		Auto Pause ² Behind PBX	No Auto Pause
04		DIU-DS Connected	DIU-DI Connected
03		DIU-DS to Modem Connection	DIU-DS to other type DCE or DTE
02		AT Commands and Result Codes	AT DIAL Command Only
01		DIU Connected	No DIU Connected

NOTES:

1. Initialized data: LED 17 ON, all others OFF.
2. Auto pause will be inserted after a Centrex or PBX access code is dialed by a DIU: CO line must be assigned in **Program 42-0**, and must have access code assigned in **Program 42** (1 ~ 8). Pause time is determined by **Program 12-3**. A pause will also be inserted after the CO line access code is dialed (by the DIU) in all cases if LED 05 is turned on.
3. DIUs cannot be connected to PDKU1 Circuit 8, but can be connected to all 8 PDKU2 circuits. DIUs cannot be connected to PDKU in all slots (see Section 100-280-202, Worksheet 2 PDKU slot assignment table).
4. If a PDIU-DS is connected to a modem, turn LED 06 ON to cause the modem to disconnect the line when the user presses the Data Release (DRLS) button. The modem should be sent AT command "AT & D2" so it can recognize DTR pulse, and the PDIU-DS SW1-2 switch must be OFF (in the up position). This feature is for outgoing modem calls only—DTR will not pulse on incoming modem calls. Always change your telephone DIU escape sequence from "+ + +" to some other character using the ATS2 = __command to allow the modem to be issued the ATH (Hang-up) command.
5. If a PC is connected to the DIU, the escape sequence of the DIU should be installed in the PC communication software "Modem Initialization" character sequence. This will ensure that the escape sequence is restored in case the Telephone or DIU is unplugged temporarily.

PROGRAM 21 — MODEM POOL PORT ASSIGNMENTS

##1*2*3 - Spkr 2 1 Hold - Spkr [] [] [] # [] [] - Hold - Spkr ## Hold - Spkr ## Hold

RDSU or PDKU/PDIU-DS, Port Number

RSTU, PSTU, PESU, or RDSU/RSTS
Modem Port Number

Copy this page if more than 10 modems are assigned to modem pool.

**RDSU or PDKU/PDIU-DS
Port Number**

**RSTU, PSTU, PESU, or RDSU/RSTS
Modem Port Number**

Assignment 1	<input type="text"/>	<input type="text"/>
Assignment 2	<input type="text"/>	<input type="text"/>
Assignment 3	<input type="text"/>	<input type="text"/>
Assignment 4	<input type="text"/>	<input type="text"/>
Assignment 5	<input type="text"/>	<input type="text"/>
Assignment 6	<input type="text"/>	<input type="text"/>
Assignment 7	<input type="text"/>	<input type="text"/>
Assignment 8	<input type="text"/>	<input type="text"/>
Assignment 9	<input type="text"/>	<input type="text"/>
Assignment 10	<input type="text"/>	<input type="text"/>

NOTES:

1. For more information, see the instructions preceding the record sheets.
2. Initialized data is blank.
3. DIUs can be connected to any ports associated with PDKU circuits, except for ports associated with Circuit 8 on a PDKU1. All PDKU2 circuits can support DIUs.
4. PDIU-DS must be installed on PDKUs in slots designated for DIU operation (see Section 100-280-202, Worksheet 2—PDKU slot assignment table).

PROGRAMMING PROCEDURES — RECORD SHEETS

SECTION 100-280-303

PROGRAM 22 — DATA INTERFACE UNIT (DIU) STATION HUNTING (DATA CALLS ONLY)

##1*2*3-Spkr 22 Hold-Spkr [] [] []-#-[] [] []-Hold-Spkr## Hold-Spkr## Hold

SELECT = Port Number (000 ~ 239)
 Enter the PDKU or RDSU/DIU port number of the "hunt-from" station. See Note 3 for entering a range of ports.

HUNT TO = (000 ~ 239)
 Enter the "hunt-to" PDKU or RDSU/DIU port number. See Note 4.

Port	000	001	002	003	004	005	006	007	008	009	010	011	012	013	014	015
Hunt To																
	016	017	018	019	020	021	022	023	024	025	026	027	028	029	030	031
	032	033	034	035	036	037	038	039	040	041	042	043	044	045	046	047
	048	049	050	051	052	053	054	055	056	057	058	059	060	061	062	063
	064	065	066	067	068	069	070	071	072	073	074	075	076	077	078	079
	080	081	082	083	084	085	086	087	088	089	090	091	092	093	094	095
	096	097	098	099	100	101	102	103	104	105	106	107	108	109	110	111
	112	113	114	115	116	117	118	119	120	121	122	123	124	125	126	127
	128	129	130	131	132	133	134	135	136	137	138	139	140	141	142	143
	144	145	146	147	148	149	150	151	152	153	154	155	156	157	158	159
	160	161	162	163	164	165	166	167	168	169	170	171	172	173	174	175
	176	177	178	179	180	181	182	183	184	185	186	187	188	189	190	191
	192	193	194	195	196	197	198	199	200	201	202	203	204	205	206	207
	208	209	210	211	212	213	214	215	216	217	218	219	220	221	222	223
	224	225	226	227	228	229	230	231	232	233	234	235	236	237	238	239

NOTES:

- For more information, see the instructions preceding the record sheets.
- Initialized data does not assign "hunt-to" ports to any port.
- A range of ports may be assigned by pressing the following key sequence:



Low port — High port

- Press Button/LED 01 to delete a digit from "hunt-to" port.
- Program 22** applies to PDIU-DI and PDIU-DS data stations. If programming a PDIU-DI station, use the associated digital telephone port number; the PDIU-DS is programmed using its own unique port number.

PROGRAM 23 — PRIMARY AUTO ATTENDANT ANNOUNCEMENT DEVICE ASSIGNMENTS

##1*2*3 - Spkr 23 Hold - Spkr - - Hold - Spkr ## Hold

SELECT = 1 ~ 4
Select the Auto Attendant Device (Digital Announcer).

AUTO ATT 1 NO. = Port
Enter the port number that the device will be assigned to.

Device	Port Number
1	
2	
3	
4	

PROGRAM 24 — SECONDARY AUTO ATTENDANT ANNOUNCEMENT DEVICE ASSIGNMENTS

##1*2*3 - Spkr 24 Hold - Spkr - - Hold - Spkr ## Hold

SELECT = 1 ~ 4
Select the Auto Attendant Device (Digital Announcer).

AUTO ATT 2 NO. = Port
Enter the port number that the device will be assigned to.

Device	Port Number
1	
2	
3	
4	

PROGRAM 25-1 — INCOMING AUTO ATTENDANT CALL OVERFLOW TIME

##1*2*3 - Spkr 25 Hold - Spkr 1 - - Hold - Spkr ## Hold - Spkr ## Hold

SELECT = 1

AATT TIME = Seconds Before Overflowing
Enter the number of seconds, 12 ~ 24.

NOTES:

1. For more information, see the instructions preceding the record sheets.
2. Overflow stations and delay ring operation is assigned in **Programs 81 ~ 89**.
3. Default overflow time is 20 seconds.
4. This overflow time applies to the overflow of incoming Auto Attendant calls to normal CO line ringing if either a primary announcement device or RRCS (DTMF) circuit is not available.

PROGRAM 26 — BUILT-IN AUTO ATTENDANT CAMP-ON-BUSY TIME

###1*2*3 - Spkr 2 6 Hold - Spkr [] [] [] # [] [] [] Hold - Spkr ## Hold - Spkr ## Hold

SELECT = Port Number (000~239)
 Enter the number of the called port that needs a Camp-on-Busy time assigned.
 See Note 2 for entering a range of ports.

HOLD TIME = Auto Attendant (AA) Camp-on-Busy Time
 Enter the Time (in seconds). The acceptable range is 011 ~ 999 seconds. Use three digits. See Note 3.

Port	000	001	002	003	004	005	006	007	008	009	010	011	012	013	014	015
Hold Time																
	016	017	018	019	020	021	022	023	024	025	026	027	028	029	030	031
	032	033	034	035	036	037	038	039	040	041	042	043	044	045	046	047
	048	049	050	051	052	053	054	055	056	057	058	059	060	061	062	063
	064	065	066	067	068	069	070	071	072	073	074	075	076	077	078	079
	080	081	082	083	084	085	086	087	088	089	090	091	092	093	094	095
	096	097	098	099	100	101	102	103	104	105	106	107	108	109	110	111
	112	113	114	115	116	117	118	119	120	121	122	123	124	125	126	127
	128	129	130	131	132	133	134	135	136	137	138	139	140	141	142	143
	144	145	146	147	148	149	150	151	152	153	154	155	156	157	158	159
	160	161	162	163	164	165	166	167	168	169	170	171	172	173	174	175
	176	177	178	179	180	181	182	183	184	185	186	187	188	189	190	191
	192	193	194	195	196	197	198	199	200	201	202	203	204	205	206	207
	208	209	210	211	212	213	214	215	216	217	218	219	220	221	222	223
	224	225	226	227	228	229	230	231	232	233	234	235	236	237	238	239

NOTES:

1. Initialized data assigns a AA Camp-on-Busy Time of 016 seconds to all ports.
2. To enter a range of ports, key in the sequence: [] [] [] * [] [] []

Low port ┘ High port

3. 999 seconds equals 16.65 minutes.
4. This timer sets the time that Auto Attendant calls to a busy station will camp-on before routing back to a primary announcement or to the calling CO line's normal ring pattern. (See **Program 10-3**, LED 3 for routing option after Camp-on-Busy). The time set in this program applies to the called station.
5. This program only applies to Auto Attendant (Built-in) calls; it does not apply to ring transfer camp-on time from stations or customer-supplied Auto Attendant devices; see **Program 37** Ring Transfer (Camp-on) recall time.
6. If CF-NA or CF-B/NA is set on a Telephone, the CF-N/A ring timer will have priority over this 16-sec camp-on-busy timer. Auto Attendant calls to a ring-no-answer or busy station will only forward to one destination, if the CF destination station has call forward set, the call will camp-on for 16-seconds and then route per the Auto Attendant flow diagram—the call will not forward a second time to another destination.

PROGRAM 28 — DSS CONSOLE/ATTENDANT TELEPHONE ASSIGNMENTS

###1*2*3 - Spkr 2 8 Hold - Spkr [] [] Hold - Spkr ## Hold - Spkr ## Hold

SELECT = (1 ~ 8). Enter the DSS console number. See Note 2.

DSS ATT = (1 ~ 8)
Enter the attendant digital or electronic telephone number.

DDSS PDKU/ HDSS PEKU PCBs (Lowest Slot to Highest)	DDSS/HDSS Console Number	Attendant Digital/ Electronic Telephone Number (1, 2, 3, 4, 5, 6, 7, 8)
Low Slot Number:	1	
Slot Number:	2	
Slot Number:	3	
Slot Number:	4	
Slot Number:	5	
Slot Number:	6	
Slot Number:	7	
High Slot Number:	8	

NOTES:

1. For more information, see the instructions preceding the record sheets.
2. Digital DSS consoles (DDSS console) should be assigned to digital telephones, and electronic DSS consoles (HDSS console) should be assigned to electronic telephones.
3. Refer to **Program 03, Flexible PCB Slot Assignments**, for the PCB slots of PEKUs and PDKUs configured to support consoles.
4. The system automatically assigns the console supported by the PEKU or PDKU in the lowest-number PCB slot to be Console number 1. See Note 8.
5. The system automatically assigns the telephone connected to the first station port on a console PDKU or PEKU to be attendant number 1. See Note 8.
6. If more than one console is associated with one attendant telephone, then specify the same number attendant telephone for all consoles associated with it.
7. Initialized data assigns Console #1 to Attendant Telephone #1; Console #2 to Attendant Telephone #2; Console #3 to Attendant Telephone #3 and Console #4 to Attendant Telephone #4, etc.
8. RCTUA can support 3 DSS consoles; RCTUB, 4 DSS consoles; and RCTUC/D, 8 DSS consoles.

PROGRAM 29 — INITIALIZED DSS CONSOLE BUTTON ASSIGNMENTS

Group No. 1		Group No. 2		Group No. 3	
#009	#019	#029	#039	#049	NT 1(439)
#008	#018	#028	#038	#048	AC (489)
#007	#017	#027	#037	#047	#057
#006	#016	#026	#036	#046	#056
#005	#015	#025	#035	#045	#055
#004	#014	#024	#034	#044	#054
#003	#013	#023	#033	#043	#053
#002	#012	#022	#032	#042	#052
#001	#011	#021	#031	#041	#051
#000	#010	#020	#030	#040	#050

PROGRAM *29 — ADD-ON MODULE BUTTON ASSIGNMENTS

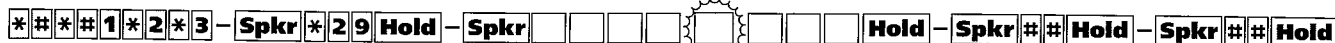

Enter the port of the telephone which will have buttons assigned to its attached Add-on Module(s).

Enter the Add-on Module which will have buttons assigned to it (0, 1, or 2). Enter 0 when removing ADMs.

Key No. 01 ~ 20

Press the LED that is in the same position as the Add-on Module button being assigned.

Code:

Assign the appropriate code. See the Code table below.

Copy this page for more ports.

CODE TABLE	
BUTTON TYPE	CODE
DSS (STATION ACCESS)	#000 ~ #239
CO LINE ACCESS	001 ~ 144
SYSTEM SPEED DIAL ⁴	*600 ~ *699 or *60 ~ *99
STATION SPEED DIAL	*10 ~ *49

Initialized Data:

ADM1:

Key 01 ~ 20 is #000 ~ #019

ADM2:

Key 01 ~ 20 is #020 ~ #039

PORT 000					
ADD-ON MODULE 1 BUTTON/CODE			ADD-ON MODULE 2 BUTTON/CODE		
10/	#010	20/	#020	10/	20/
09/	#009	19/	#019	09/	19/
08/	#008	18/	#018	08/	18/
07/	#007	17/	#017	07/	17/
06/	#006	16/	#016	06/	16/
05/	#005	15/	#015	05/	15/
04/	#004	14/	#014	04/	14/
03/	#003	13/	#013	03/	13/
02/	#002	12/	#012	02/	12/
01/	#001	11/	#011	01/	11/

PORT _____					
ADD-ON MODULE 1 BUTTON/CODE			ADD-ON MODULE 2 BUTTON/CODE		
10/		20/		10/	20/
09/		19/		09/	19/
08/		18/		08/	18/
07/		17/		07/	17/
06/		16/		06/	16/
05/		15/		05/	15/
04/		14/		04/	14/
03/		13/		03/	13/
02/		12/		02/	12/
01/		11/		01/	11/

PORT _____					
ADD-ON MODULE 1 BUTTON/CODE			ADD-ON MODULE 2 BUTTON/CODE		
10/		20/		10/	20/
09/		19/		09/	19/
08/		18/		08/	18/
07/		17/		07/	17/
06/		16/		06/	16/
05/		15/		05/	15/
04/		14/		04/	14/
03/		13/		03/	13/
02/		12/		02/	12/
01/		11/		01/	11/

PORT _____					
ADD-ON MODULE 1 BUTTON/CODE			ADD-ON MODULE 2 BUTTON/CODE		
10/		20/		10/	20/
09/		19/		09/	19/
08/		18/		08/	18/
07/		17/		07/	17/
06/		16/		06/	16/
05/		15/		05/	15/
04/		14/		04/	14/
03/		13/		03/	13/
02/		12/		02/	12/
01/		11/		01/	11/

NOTES:

- For more information, see the instructions preceding the record sheets.
- RCTUA can support 12 Add-on Modules; RCTUB, 40 Add-on Modules; and RCTUC/RCTUD, 120 Add-on Modules.
- Important note: This Program must be run for each station that has an ADM equipped or the ADM will not function. At least one ADM key must be programmed for each ADM.**
- RCTUA provides 40 system speed dial numbers (60 ~ 99), RCTU B and RCTU C/D provides 100 system speed dial numbers (600 ~ 699).

PROGRAMMING PROCEDURES — RECORD SHEETS

SECTION 100-280-303

PROGRAM *30 — GROUP PAGE ASSIGNMENTS

###1*2*3 - Spkr *30 Hold - Spkr #  Hold - Spkr ## Hold - Spkr ## Hold

Enter the port which will be assigned to a page group or groups.

Buttons/LEDs
Light LEDs for the port specified in the last step. All buttons/LEDs marked with an "X" in the table below should be lit.

Select Port Range	
000 ~ 039	120 ~ 159
040 ~ 079	160 ~ 199
080 ~ 119	200 ~ 239

Copy this page for more ports.

FEATURE	PORT →																		
	LED ↓																		
PAGE GROUP H	08																		
PAGE GROUP G	07																		
PAGE GROUP F	06																		
PAGE GROUP E	05																		
PAGE GROUP D	04																		
PAGE GROUP C	03																		
PAGE GROUP B	02																		
PAGE GROUP A	01																		

Select Port Range	
000 ~ 039	120 ~ 159
040 ~ 079	160 ~ 199
080 ~ 119	200 ~ 239

FEATURE	PORT →																		
	LED ↓																		
PAGE GROUP H	08																		
PAGE GROUP G	07																		
PAGE GROUP F	06																		
PAGE GROUP E	05																		
PAGE GROUP D	04																		
PAGE GROUP C	03																		
PAGE GROUP B	02																		
PAGE GROUP A	01																		

NOTES:

1. Initialized data reads all LEDs off.
2. RCTUA and RCTUB can support four groups, and RCTUC/RCTUD can support eight groups.
3. A maximum of 120 telephones can be assigned to a particular page group.
4. Specify a range of ports by keying in: *

Low port High port

5. Only 120 telephones can be paged simultaneously. Example: If Page Group "A" has 60 telephones, Page Group "B" has 50 telephones, and Page Group "C" has 70 telephones, then Group A + B (60 + 50 = 110) can be, Group B + C (50 + 70 = 120) can be, but Group A + C (60 + 70 = 130) can not be paged simultaneously.

PROGRAM *31 — GROUP PICKUP ASSIGNMENTS

##1*2*3 — Spkr *3 1 Hold — Spkr #  Hold — Spkr ## Hold — Spkr ## Hold

Enter the port which will be assigned to a pickup group or pickup groups.

Buttons/LEDs
Light LEDs for the port specified in the last step. All buttons/LEDs marked with an "X" in the table below should be lit.

Select Port Range			
000 ~ 039		120 ~ 159	
040 ~ 079		160 ~ 199	
080 ~ 119		200 ~ 239	

Copy this page for more ports.

PICKUP GROUP	PORT →																		
	LED ↓																		
PICKUP GROUP 20	20																		
PICKUP GROUP 19	19																		
PICKUP GROUP 18	18																		
PICKUP GROUP 17	17																		
PICKUP GROUP 16	16																		
PICKUP GROUP 15	15																		
PICKUP GROUP 14	14																		
PICKUP GROUP 13	13																		
PICKUP GROUP 12	12																		
PICKUP GROUP 11	11																		
PICKUP GROUP 10	10																		
PICKUP GROUP 9	09																		
PICKUP GROUP 8	08																		
PICKUP GROUP 7	07																		
PICKUP GROUP 6	06																		
PICKUP GROUP 5	05																		
PICKUP GROUP 4	04																		
PICKUP GROUP 3	03																		
PICKUP GROUP 2	02																		
PICKUP GROUP 1	01																		

NOTES:

1. Initialized data reads all LEDs off.

2. Specify a range of ports by keying in: *

Low port High port

PROGRAMMING PROCEDURES — RECORD SHEETS

SECTION 100-280-303

PROGRAM 32 — AUTOMATIC PREFERENCE (PORTS 000 ~ 119)

##1*2*3 - Spkr 3 2 Hold - Spkr [] [] [] # [] [] Hold - Spkr ## Hold - Spkr ## Hold

SELECT = Port Number
Enter the port number of the station having preference defined. See note below for entering a range of ports.

DATA = Ringing Code
Enter 0 to disable Ringing Line Preference.
Enter 1 to enable Ringing Line Preference.

Automatic Preference Code:
Enter 00 for no selection.
Enter 01 for intercom.
Enter 02 for lowest CO line.
Enter 11 ~ 26 for line groups 1 ~ 16⁴.

Port Number	Ringing Code (0 or 1)	Automatic Preference Code	Port Number	Ringing Code (0 or 1)	Automatic Preference Code	Port Number	Ringing Code (0 or 1)	Automatic Preference Code
000	1	01	040			080		
001			041			081		
002			042			082		
003	1		043			083		
004	1	01	044			084		
005			045			085		
006			046			086		
007			047			087		
008			048			088		
009			049			089		
010			050			090		
011			051			091		
012			052			092		
013			053			093		
014			054			094		
015			055			095		
016			056			096		
017			057			097		
018			058			098		
019			059			099		
020			060			100		
021			061			101		
022			062			102		
023			063			103		
024			064			104		
025			065			105		
026			066			106		
027			067			107		
028			068			108		
029			069			109		
030			070			110		
031			071			111		
032			072			112		
033			073			113		
034			074			114		
035			075			115		
036			076			116		
037			077			117		
038			078			118		
039			079			119		

NOTES:

- For more information, see the instructions preceding the records sheets.
- Initialized data assigns Ringing Code 1 and Automatic Off-hook (Preference) Code 00 for all ports.
- To enter a range of ports dial the following key sequence: [] [] [] * [] [] []

Low port ————— High port

- RCTUA and RCTUB provides 8 CO line groups, RCTU C/D provides 16 CO line groups.

PROGRAMMING PROCEDURES — RECORD SHEETS

SECTION 100-280-303

PROGRAM 32 — AUTOMATIC PREFERENCE (PORTS 120 ~ 239) (continued)

##*#1*2*3 - Spkr 3 2 Hold - Spkr [] [] [] # - [] [] [] Hold - Spkr ## Hold - Spkr ## Hold

SELECT = Port Number ————— Automatic Preference Code:
 Enter the port number of the station having preference defined. See note below for entering a range of ports.
 DATA = Ringing Code ————— Enter 00 for no selection.
 Enter 0 to disable Ringing Line Preference.⁵ Enter 01 for intercom.⁵
 Enter 1 to enable Ringing Line Preference.⁵ Enter 02 for lowest CO line.⁵
 Enter 11 ~ 26 for line groups 1 ~ 16^{4,5}.

Port Number	Ringing Code (0 or 1)	Automatic Preference Code	Port Number	Ringing Code (0 or 1)	Automatic Preference Code	Port Number	Ringing Code (0 or 1)	Automatic Preference Code
120			160			200		
121			161			201		
122			162			202		
123			163			203		
124			164			204		
125			165			205		
126			166			206		
127			167			207		
128			168			208		
129			169			209		
130			170			210		
131			171			211		
132			172			212		
133			173			213		
134			174			214		
135			175			215		
136			176			216		
137			177			217		
138			178			218		
139			179			219		
140			180			220		
141			181			221		
142			182			222		
143			183			223		
144			184			224		
145			185			225		
146			186			226		
147			187			227		
148			188			228		
149			189			229		
150			190			230		
151			191			231		
152			192			232		
153			193			233		
154			194			234		
155			195			235		
156			196			236		
157			197			237		
158			198			238		
159			199			239		

NOTES:

- For more information, see the instructions preceding the record sheets.
- Initialized data assigns Ringing Code 1 and Automatic Off-hook (Preference) Code 00 for all ports.
- To enter a range of ports dial the following key sequence: [] [] [] * [] [] []
 Low port ————— High port
- RCTUA and RCTUB provides 8 CO line groups, RCTU C/D provides 16 CO line groups.
- Intercom, lowest CO line, or Line Group will be selected only if the telephone is not ringing when it is taken off-hook (or press Spkr). If a telephone is ringing, Auto Preference of Intercom or outgoing CO line is canceled. In this case no selection is made if ringing line Preference is disabled or the ringing line is selected if ringing line Preference is enabled.

PROGRAMMING PROCEDURES — RECORD SHEETS

SECTION 100-280-303

PROGRAM *32 — RS-232 (SMDI OR TOSHIBA PROPRIETARY) VOICE MAIL MESSAGE CENTER PORT³

##1*2*3 - Spkr *32 Hold - Spkr [] [] [] # [] [] [] Hold - Spkr ## Hold - Spkr ## Hold

SELECT = Port Number (000 ~ 239)
Enter the port number having its
Message Center assigned. Enter all
station ports using Voice Mail.

VM PORT = Enter the Voice Mail Message
Center Port number (000 ~ 239) that should
be assigned to each station. Enter the lowest
RSTU port number that is connected to the
VM machine.

Port Seconds	000	001	002	003	004	005	006	007	008	009	010	011	012	013	014	015
	016	017	018	019	020	021	022	023	024	025	026	027	028	029	030	031
	032	033	034	035	036	037	038	039	040	041	042	043	044	045	046	047
	048	049	050	051	052	053	054	055	056	057	058	059	060	061	062	063
	064	065	066	067	068	069	070	071	072	073	074	075	076	077	078	079
	080	081	082	083	084	085	086	087	088	089	090	091	092	093	094	095
	096	097	098	099	100	101	102	103	104	105	106	107	108	109	110	111
	112	113	114	115	116	117	118	119	120	121	122	123	124	125	126	127
	128	129	130	131	132	133	134	135	136	137	138	139	140	141	142	143
	144	145	146	147	148	149	150	151	152	153	154	155	156	157	158	159
	160	161	162	163	164	165	166	167	168	169	170	171	172	173	174	175
	176	177	178	179	180	181	182	183	184	185	186	187	188	189	190	191
	192	193	194	195	196	197	198	199	200	201	202	203	204	205	206	207
	208	209	210	211	212	213	214	215	216	217	218	219	220	221	222	223
	224	225	226	227	228	229	230	231	232	233	234	235	236	237	238	239

NOTES:

- For more information, see the instructions preceding the record sheets.
- Enter a range of ports by keying in the following sequence: [] [] [] * [] [] []

Low port
High port
- The same message center port should also be assigned in **Program 13**.
- See **Program 10-3** for other RS-232 Voice Mail Interface Programs.
- SMDI and Toshiba Proprietary Voice Mail Interface are available with RCTUB2 and RCTU C/D2 Release 2 and above only.

This page intentionally left blank.

PROGRAMMING PROCEDURES — RECORD SHEETS

SECTION 100-280-303

PROGRAM 33 — STATION HUNTING (VOICE CALLS ONLY)³

##1*2*3 - Spkr 3 3 Hold - Spkr -#- - Hold - Spkr ## Hold - Spkr ## Hold

SELECT = Port Number (000 ~ 239)
Enter the port number of the
"hunt-from" station. See note below
for entering a range of ports.

HUNT TO = (000 ~ 239)
Enter the "hunt-to"
port number.
See Note 4.

Port	000	001	002	003	004	005	006	007	008	009	010	011	012	013	014	015
Hunt To																
	016	017	018	019	020	021	022	023	024	025	026	027	028	029	030	031
	032	033	034	035	036	037	038	039	040	041	042	043	044	045	046	047
	048	049	050	051	052	053	054	055	056	057	058	059	060	061	062	063
	064	065	066	067	068	069	070	071	072	073	074	075	076	077	078	079
	080	081	082	083	084	085	086	087	088	089	090	091	092	093	094	095
	096	097	098	099	100	101	102	103	104	105	106	107	108	109	110	111
	112	113	114	115	116	117	118	119	120	121	122	123	124	125	126	127
	128	129	130	131	132	133	134	135	136	137	138	139	140	141	142	143
	144	145	146	147	148	149	150	151	152	153	154	155	156	157	158	159
	160	161	162	163	164	165	166	167	168	169	170	171	172	173	174	175
	176	177	178	179	180	181	182	183	184	185	186	187	188	189	190	191
	192	193	194	195	196	197	198	199	200	201	202	203	204	205	206	207
	208	209	210	211	212	213	214	215	216	217	218	219	220	221	222	223
	224	225	226	227	228	229	230	231	232	233	234	235	236	237	238	239

NOTES:

1. For more information, see the instructions preceding the record sheets.
2. Initialized data does not assign "hunt-to" points to any port.
3. A range of ports may be assigned by pressing the following key sequence:

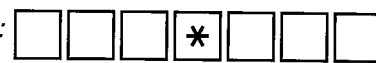

Low port ——— High port

4. Press Button LED 01 to delete a digit from the "hunt-to" port.

PROGRAMMING PROCEDURES — RECORD SHEETS

SECTION 100-280-303

PROGRAM 34 — HOLD/PARK RECALL TIMING

##1*2*3 - Spkr 3 4 Hold - Spkr # Hold - Spkr ## Hold - Spkr ## Hold

SELECT = Port Number (000 ~ 239)
 Enter the port number having its
 Hold/Park Recall Time defined. See
 Note 4 for entering a range of ports.

HOLD TIME = Seconds
 Enter the number of seconds the system will
 wait. Use three digits. Acceptable range is
 000 or 011 ~ 160. See Note 3.

Port	000	001	002	003	004	005	006	007	008	009	010	011	012	013	014	015
Seconds	060	→														
	016	017	018	019	020	021	022	023	024	025	026	027	028	029	030	031
	032	033	034	035	036	037	038	039	040	041	042	043	044	045	046	047
	048	049	050	051	052	053	054	055	056	057	058	059	060	061	062	063
	064	065	066	067	068	069	070	071	072	073	074	075	076	077	078	079
	080	081	082	083	084	085	086	087	088	089	090	091	092	093	094	095
	096	097	098	099	100	101	102	103	104	105	106	107	108	109	110	111
	112	113	114	115	116	117	118	119	120	121	122	123	124	125	126	127
	128	129	130	131	132	133	134	135	136	137	138	139	140	141	142	143
	144	145	146	147	148	149	150	151	152	153	154	155	156	157	158	159
	160	161	162	163	164	165	166	167	168	169	170	171	172	173	174	175
	176	177	178	179	180	181	182	183	184	185	186	187	188	189	190	191
	192	193	194	195	196	197	198	199	200	201	202	203	204	205	206	207
	208	209	210	211	212	213	214	215	216	217	218	219	220	221	222	223
	224	225	226	227	228	229	230	231	232	233	234	235	236	237	238	239

NOTES:

1. For more information, see the instructions preceding the record sheets.
2. Initialized data assigns a Hold/Park Recall Time of 032 seconds to all ports.
3. Enter 000 for no Hold Recall. Enter 011 ~ 160 for 11 to 160 seconds.
4. Enter a range of ports by keying in the following sequence:

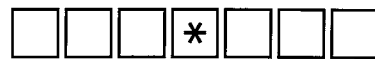

Low port — High port

PROGRAM 35 — STATION CLASS OF SERVICE

##1*2*3 - Spkr 3 5 Hold - Spkr [] [] [] # →  Hold - Spkr ## Hold - Spkr ## Hold

SELECT = Port Number (000 ~ 239) Enter the port number(s) being defined. See note 1 below for entering a range of ports.

LED – Select LEDs to light for the port specified in the last step. All LEDs marked with an "X" in the table below should be lit.

Select Port Range	
000 ~ 039	120 ~ 159
040 ~ 079	160 ~ 199
080 ~ 119	200 ~ 239

Copy this page for more ports

Feature	PORT →																		
	LED ↓																		
Busy Station Transfer	20																		
Busy Station Ringing	19																		
Automatic Hold	18																		
DKT 2000 Telephone Continuous DTMF Tones Off	17																		
No CF/NA Handsfree	16																		
	15																		
	14																		
	13																		
	12																		
	11																		
	10																		
	09																		
	08																		
	07																		
	06																		
LCD Personal Message (10-19) Allowed	05																		
Message Waiting (RCV) ⁴	04																		
	03																		
LCD Type/32-ON/12-OFF ⁴	02																		
LCD Display ⁴	01																		

Select Port Range	
000 ~ 039	120 ~ 159
040 ~ 079	160 ~ 199
080 ~ 119	200 ~ 239

Feature	PORT →																		
	LED ↓																		
Busy Station Transfer	20																		
Busy Station Ringing	19																		
Automatic Hold	18																		
DKT 2000 Telephone Continuous DTMF Tones Off	17																		
No CF/NA Handsfree	16																		
	15																		
	14																		
	13																		
	12																		
	11																		
	10																		
	09																		
	08																		
	07																		
	06																		
LCD Personal Message (10-19) Allowed	05																		
Message Waiting (RCV) ⁴	04																		
	03																		
LCD Type/32-ON/12-OFF ⁴	02																		
LCD Display ⁴	01																		

NOTES:

1. Enter a range of ports by keying in the following sequence: *
Low port High port
2. Maximum LCD Telephones with Personal Messages:
 RCTUC/D = 96, RCTUB = 32, RCTUA = 16
3. Initialized data LED 01, 02, 04, 05, 16 are ON, all other LEDs off. The lowest port numbers (96, 32, 16-note 3) are initialized with LED 05 ON (LCD messages). To enable a higher port number with LCD message (LED 05 ON) a lower port must be disabled (LED 05 OFF).
4. LEDs 01, 02, and 04 must be on to allow the Telephone's msg waiting LED to function with voice mail—even if the Telephone is not an LCD type.

PROGRAMMING PROCEDURES — RECORD SHEETS

SECTION 100-280-303

PROGRAM 36 — FIXED CALL FORWARD (VOICE CALLS ONLY)

##1*2*3 - Spkr 3 6 Hold - Spkr [] [] [] # [] [] [] Hold - Spkr ## Hold - Spkr ## Hold

SELECT = Port Number (000 ~ 239)
Enter the port number of the station that needs a Fixed Call Forward location assigned. See Note 3 for a range of ports.

FORWARD TEL = Port Number (000 ~ 239)
Enter the port number of the station or VM port that will be call forwarded to when the Fixed Call Forward button is pressed.

Port Forward Tel	000	001	002	003	004	005	006	007	008	009	010	011	012	013	014	015
	016	017	018	019	020	021	022	023	024	025	026	027	028	029	030	031
	032	033	034	035	036	037	038	039	040	041	042	043	044	045	046	047
	048	049	050	051	052	053	054	055	056	057	058	059	060	061	062	063
	064	065	066	067	068	069	070	071	072	073	074	075	076	077	078	079
	080	081	082	083	084	085	086	087	088	089	090	091	092	093	094	095
	096	097	098	099	100	101	102	103	104	105	106	107	108	109	110	111
	112	113	114	115	116	117	118	119	120	121	122	123	124	125	126	127
	128	129	130	131	132	133	134	135	136	137	138	139	140	141	142	143
	144	145	146	147	148	149	150	151	152	153	154	155	156	157	158	159
	160	161	162	163	164	165	166	167	168	169	170	171	172	173	174	175
	176	177	178	179	180	181	182	183	184	185	186	187	188	189	190	191
	192	193	194	195	196	197	198	199	200	201	202	203	204	205	206	207
	208	209	210	211	212	213	214	215	216	217	218	219	220	221	222	223
	224	225	226	227	228	229	230	231	232	233	234	235	236	237	238	239

NOTES:

1. For more information, see the instructions preceding the record sheets.
2. Initialized data does not assign a Fixed Call Forward location to any port.
3. To enter a range of ports, key in the following sequence:

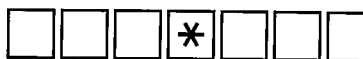

4. Press Button/LED 01 to enter blanks.

PROGRAM 37 — CO AND TIE LINE RING TRANSFER (CAMP-ON) RECALL TIME

##1*2*3 - Spkr 3 7 Hold - Spkr [] [] [] # [] [] [] Hold - Spkr # # Hold - Spkr # # # Hold

SELECT = Port Number (000 ~ 239)
 Enter the number of the port that needs a Ring Transfer Recall time assigned. See Note 3 for entering a range of ports.

HOLD TIME = Ring Transfer Recall Time
 Enter the Ring Transfer Recall Time (in seconds). The acceptable range is 011 ~ 999 seconds. Use three digits.

Port	000	001	002	003	004	005	006	007	008	009	010	011	012	013	014	015
Hold Time	032															
	016	017	018	019	020	021	022	023	024	025	026	027	028	029	030	031
	032	033	034	035	036	037	038	039	040	041	042	043	044	045	046	047
	048	049	050	051	052	053	054	055	056	057	058	059	060	061	062	063
	064	065	066	067	068	069	070	071	072	073	074	075	076	077	078	079
	080	081	082	083	084	085	086	087	088	089	090	091	092	093	094	095
	096	097	098	099	100	101	102	103	104	105	106	107	108	109	110	111
	112	113	114	115	116	117	118	119	120	121	122	123	124	125	126	127
	128	129	130	131	132	133	134	135	136	137	138	139	140	141	142	143
	144	145	146	147	148	149	150	151	152	153	154	155	156	157	158	159
	160	161	162	163	164	165	166	167	168	169	170	171	172	173	174	175
	176	177	178	179	180	181	182	183	184	185	186	187	188	189	190	191
	192	193	194	195	196	197	198	199	200	201	202	203	204	205	206	207
	208	209	210	211	212	213	214	215	216	217	218	219	220	221	222	223
	224	225	226	227	228	229	230	231	232	233	234	235	236	237	238	239

NOTES:

1. For more information, see the instructions preceding the record sheets.
2. Initialized data assigns a Ring Transfer Recall Time of 32 seconds to all ports.
3. To enter a range of ports, key in the following sequence:

[] [] [] * [] [] []

Low port

High port

PROGRAMMING PROCEDURES — RECORD SHEETS

SECTION 100-280-303

PROGRAM 38 — DIGITAL AND ELECTRONIC TELEPHONE KEYSTRIP TYPE

##1*2*3 - Spkr 3 8 Hold - Spkr # Hold - Spkr ## Hold - Spkr ## Hold

SELECT = Port Number (000 ~ 239)
Enter the port number of the station that needs a keystrip defined. See Note 4 for entering a range of ports.

KEY MENU = Code
Enter the appropriate code as follows:

Telephone Type	Code
10-button	21
20-button (A)	31
20-button (B)	32
20-button (C)	33

Port Key Menu	000	001	002	003	004	005	006	007	008	009	010	011	012	013	014	015
	016	017	018	019	020	021	022	023	024	025	026	027	028	029	030	031
	032	033	034	035	036	037	038	039	040	041	042	043	044	045	046	047
	048	049	050	051	052	053	054	055	056	057	058	059	060	061	062	063
	064	065	066	067	068	069	070	071	072	073	074	075	076	077	078	079
	080	081	082	083	084	085	086	087	088	089	090	091	092	093	094	095
	096	097	098	099	100	101	102	103	104	105	106	107	108	109	110	111
	112	113	114	115	116	117	118	119	120	121	122	123	124	125	126	127
	128	129	130	131	132	133	134	135	136	137	138	139	140	141	142	143
	144	145	146	147	148	149	150	151	152	153	154	155	156	157	158	159
	160	161	162	163	164	165	166	167	168	169	170	171	172	173	174	175
	176	177	178	179	180	181	182	183	184	185	186	187	188	189	190	191
	192	193	194	195	196	197	198	199	200	201	202	203	204	205	206	207
	208	209	210	211	212	213	214	215	216	217	218	219	220	221	222	223
	224	225	226	227	228	229	230	231	232	233	234	235	236	237	238	239

NOTES:

1. For more information, see the instructions preceding the record sheets.
2. Initialized data assigns Code 31 to all ports.
3. Always complete **Program 38** before proceeding to **Program 39**.
4. To enter a range of ports, key in the sequence:

*

Low port

High port

PROGRAM 38 — DIGITAL AND ELECTRONIC TELEPHONE KEYSTRIIP TYPE (continued)

5. Assignments for 2000-series Digital Telephone keystrips are as follows:

Speed Dial
Do Not Disturb
Line 7
Line 6
Line 5
Line 4
Line 3
Line 2
Line 1
Intercom

Code 21
10-button

Line 9	Speed Dial
Line 8	Do Not Disturb
Line 7	Line 17*
Line 6	Line 16
Line 5	Line 15
Line 4	Line 14
Line 3	Line 13
Line 2	Line 12
Line 1	Line 11
Intercom	Line 10

Code 31 (Default)
20-button (A)

Line 9	Speed Dial
Line 8	Do Not Disturb
Line 7	SD 14
Line 6	SD 13
Line 5	SD 12
Line 4	SD 11
Line 3	SD 10
Line 2	Line 12
Line 1	Line 11
Intercom	Line 10

Code 32
20-button (B)

SD 10	Flash
Line 8	Do Not Disturb
Line 7	Speed Dial
Line 6	Redial
Line 5	Spd Dial Pause
Line 4	SD 15
Line 3	SD 14
Line 2	SD 13
Line 1	SD 12
Intercom	SD 11

Code 33
20-button (C)
(Keystrip not provided, but can be assigned)

NOTE: The Speed Dial button is the same as the SDS or REP buttons in previous STRATA systems (Program 39, Code 97).

6. Assignments for 1000-series Digital Telephone keystrips are as follows:

CO15	CO16	CO17*	DND	SDS	SD12	SD13	SD14	DND	SDS	PAU	RDL	SDS	DND	FLASH
CO10	CO11	CO12	CO13	CO14	CO10	CO11	CO12	SD10	SD11	SD11	SD12	SD13	SD14	SD15
CO5	CO6	CO7	CO8	CO9	CO5	CO6	CO7	CO8	CO9	CO5	CO6	CO7	CO8	SD10
INT	CO1	CO2	CO3	CO4	INT	CO1	CO2	CO3	CO4	INT	CO1	CO2	CO3	CO4

Code 31 (Default)
20-key (A)

Code 32
20-key (B)

Code 33
20-key (C)

* This button is initialized as SD10 with RCTUA since there are only 16 CO lines.

PROGRAM 38 — DIGITAL AND ELECTRONIC TELEPHONE KEYSRIP TYPE (continued)

7. The electronic telephone keystrip code assignments are as follows:

MW/FL	CO9	MW/FL	CO9	MW/FL	SD 10	MW/FL
DND	CO8	DND	CO8	DND	CO8	DND
CO7	CO7	CO17*	CO7	SD14	CO7	SDS
CO6	CO6	CO16	CO6	SD13	CO6	RDL
CO5	CO5	CO15	CO5	SD12	CO5	PAU
CO4	CO4	CO14	CO4	SD11	CO4	SD15
CO3	CO3	CO13	CO3	SD10	CO3	SD14
CO2	CO2	CO12	CO2	CO12	CO2	SD13
CO1	CO1	CO11	CO1	CO11	CO1	SD12
INT	INT	CO10	INT	CO10	INT	SD11

Code 21
10-button

Code 31(Default)
20-button (A)

Code 32
20-button (B)

Code 33
20-button (C)

* This button is initialized as SD10 with RCTUA since there are only 16 CO lines.

8. The programming keystrips are as follows:

10 30, 50, 70 90, 110, 130	20 40, 60, 80 100, 120, 140
09 29, 49, 59 89, 109, 129	19 39, 59, 79 99, 119, 139
08 28, 48, 68 88, 108, 128	18 38, 58, 78 98, 118, 138
07 27, 47, 67 87, 107, 127	17 37, 57, 77 97, 117, 137
06 26, 46, 66 86, 106, 126	16 36, 56, 76 96, 116, 136
05 25, 45, 65 85, 105, 125	15 35, 55, 75 95, 115, 135
04 24, 44, 64 84, 104, 124, 144	14 34, 54, 74 94, 114, 134
03 23, 43, 63 83, 103, 123, 143	13 33, 53, 73 93, 113, 133
02 22, 42, 62 82, 102, 122, 142	12 32, 52, 72 92, 112, 132
01 21, 41, 61 81, 101, 121, 141	11 31, 51, 71 91, 111, 131

2000-series Digital Telephone

16, 36, 56, 76 96, 116, 136	17, 37, 57, 77 97, 117, 137	18, 38, 58, 78 98, 118, 138	19, 39, 59, 79 99, 119, 139	20, 40, 60, 80 100, 120, 140
11, 31, 51, 71 91, 111, 131	12, 32, 52, 72 92, 112, 132	13, 33, 53, 73 93, 113, 133	14, 34, 54, 74 94, 114, 134	15, 35, 55, 75 95, 115, 135
06, 26, 46, 66 86, 106, 126	07, 27, 47, 67 87, 107, 127	08, 28, 48, 68 88, 108, 128	09, 29, 49, 59 89, 109, 129	10, 30, 50, 70 90, 110, 130
01, 21, 41, 61 81, 101, 121, 141	02, 22, 42, 62 82, 102, 122, 142	03, 23, 43, 63 83, 103, 123, 143	04, 24, 44, 64 84, 104, 124, 144	05, 25, 45, 65 85, 105, 125

1000-series Digital Telephone

NOTE:

Key numbers 01 ~ 144 on Electronic Telephones (6000, 6500 series, etc) are in the same position as shown on the 2000-series Digital Telephone programming keystrip.

PROGRAM 39 — FLEXIBLE KEY ASSIGNMENT REFERENCE GUIDE

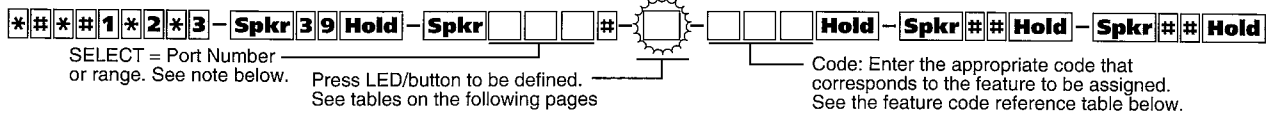

Button Function	Button Labels	Code	Notes	Button Function	Button Labels	Code	Notes
Account Code	Account Code or ACCOUNT	450	Allows a Voluntary Account Code to be entered	Door Lock 1 thru Door Lock 4 (DDCB/HDCB)	Unlock Door 1 or DRLK 1	472	Momentarily unlocks door (3 or 6 sec.) See Prog 77-1 and 77-2
Alarm	Alarm Reset or ALRM	477	Resets alarm condition system wide		Unlock Door 2 or DRLK 2	473	
All Call Voice Page	All Call Page or AC	489	Pages all idle electronic/digital telephones over speaker		Unlock Door 3 or DRLK 3	474	
Automatic Busy Redial	Auto Busy Redial or ABR	470	Sets ABR of busy outgoing number		Unlock Door 4 or DRLK 4	475	
Automatic Callback Busy	Auto Callback or ACB	494	Sets ACB for station recalled by busy line	Intercom	Intercom or INT	000	Intercom line access key
Background Music	Tel Set Music or BGM	478	Turns BGM ON or OFF through station speaker	LCD Message	MSG	481	Begins LCD message selection
Call Forward All Calls	Call Frwd All Calls or CFAC	487	All calls forward to selected station	Message Waiting and Flash	Flash or MW/FL	499	Provides message waiting LED for EKT and Flash key
Call Forward A.C. Fixed	Call Frwd to: or CFF	486	Forwards all calls to pre-defined destination. See Program 36	Microphone Cut-off	Microphn Cut-off or MCO	488	Sets microphone on/off for incoming handsfree intercom calls
Call Forward Busy	Call Frwd Busy or CFB	459	Forwards calls to selected station if station is busy	Modem	Modem or MODEM	455	Used to reserve modem in modem pool
Call Forward Busy/No Answer	Call Frwd Busy/NAns or CFB/NA	457	Forwards calls to selected station if station is busy or does not answer	Night Transfer Tenant 1	Night Transfer 1 or NT1	439	Sets Tenant 1 CO line DAY/NIGHT ringing mode
Call Forward External	CF-EXT	460	Forward calls externally	Night Transfer Tenant 2	Night Transfer 2 or NT2	440	Sets Tenant 2 CO line DAY/NIGHT ringing mode
Call Forward No Answer	Call Frwd No Answer or CFNA	458	Forwards calls to selected station if station does not answer	Night Transfer Tenant 3	Night Transfer 3 or NT3	441	Sets Tenant 3 CO line DAY/NIGHT ringing mode
Call Pickup (Directed)	Directed Pickup or PKUP	484	Picks up ringing or held intercom, trunk calls, and page	Night Transfer Tenant 4	Night Transfer 4 or NT4	442	Sets Tenant 4 CO line DAY/NIGHT ringing mode
Call Pickup 4 Tenant 4	PKUP 4	435	Picks up tenant 4's ringing CO calls	Pause	Spd Dial Pause or PAU	495	Sets pause in Speed Dial. See Program 12-3
Call Pickup 4 Tenant 3	PKUP 3	436	Picks up tenant 3's ringing CO calls	Pause (Long)	Spd Dial Lng Pause or PAU/L	493	Sets a 10-second pause in Speed Dial
Call Pickup 4 Tenant 2	PKUP 2	437	Picks up tenant 2's ringing CO calls	Pooled Line	Pooled Line Grp or PL	301 ~ 316	Multiple CO line may appear under one key
Call Pickup 4 Tenant 1	PKUP 1	438	Picks up tenant 1's ringing CO calls	Privacy	Privacy On Line or PRIVACY	453	Prevents Privacy Override (not Exc. Over.)
Call Pickup 5 (Group)	Group Pickup	480	Pick up a call to any group to which station is assigned in *31	Privacy Release	Privacy Release or PRV RLS	479	Changes station Privacy mode to Non-private for CO lines
CO Line Appearance	Line 1 ~ 144 or CO 001 ~ CO 144	000 ~ 144	CO line access of appearing calls	Redial Last Number (# Key)	RDL (EKT only)	496	Redials the last number
Data	Data Call or DATA	456	Used to place data call	Release	Release Call or RLS	476	Releases current call and makes station idle
Data Release	Data Release or DRLS	454	Releases data call	Save Last Number	Save Last Number or SAVE	485	Saves last number dialed for future speed dial
Direct Station Selection	DSS	#000 ~ #239	Assigns DSS hotline keys to port number	Speed Dial Select (* Key)	Speed Dial or SDS	497	Begins speed dial selection
Do Not Disturb	Do Not Disturb or DND	498	Prevents calls to station	Station Speed Dial Codes	SD	*10 ~ *49	Reserves key for station speed dial
Door Lock 0	Unlock Door 0 or DRLK 0	471	Momentarily unlocks door (3 or 6 sec.) PIOUS/PIOU/PEPU	System Speed Dial Codes	SD ⁶	*600 ~ *699 or *60~*99	Speed dial number set by station port 000
				Tone	Tone Dial Select or TONE	490	CO dial signals set to tone or pulse

NOTES:

1. Complete Program 38 before Program 39.
2. Initialized data assigns the keystrip pattern associated with Code 31 from Program 38.
3. Specify a range of ports by keying in: *

Low port ————— High port

4. See Program *15 for Tenant Group assignments.
5. Picks up calls to telephones in any pick up group to which the telephone is assigned in Program *31.
6. RCTUA provides 40 system speed dial numbers (60 ~ 99), RCTUB and RCTU C/D provide 100 system speed dial numbers (600 ~ 699).

PROGRAMMING PROCEDURES — RECORD SHEETS

SECTION 100-280-303

PROGRAM 39 — FLEXIBLE KEY ASSIGNMENT FOR PORTS ____ TO ____

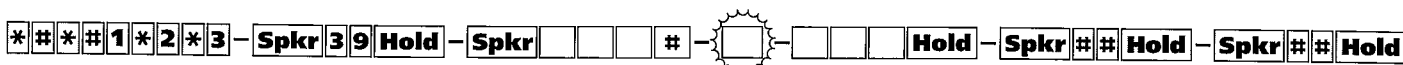

Port Number OMIT 202, 214 Code

205, + own ext.

Copy for more telephones

PORT NO. 000 <input type="checkbox"/> LCD <input type="checkbox"/>			
LOCATION: 200			
Button	Code	Button	Code
10	010	20	439
09	009	19	489
08	008	18	*99
07	007	17	497
06	006	16	470
05	005	15	494
04	004	14	*70
03	003	13	499
02	002	12	476
01	001	11	000

PORT NO. ____ <input type="checkbox"/> LCD <input type="checkbox"/>			
LOCATION: ALL			
Button	Code	Button	Code
10	#000	20	DSS
09	*99	19	
08	499	18	
07	498	17	
06	470	16	
05	497	15	
04	301	14	
03	301	13	
02	301	12	
01	000	11	DSS

PORT NO. ____ <input type="checkbox"/> LCD <input type="checkbox"/>			
LOCATION:			
Button	Code	Button	Code
10		20	
09		19	
08		18	
07		17	
06		16	
05		15	
04		14	
03		13	
02		12	
01		11	

PORT NO. ____ <input type="checkbox"/> LCD <input type="checkbox"/>			
LOCATION:			
Button	Code	Button	Code
10		20	
09		19	
08		18	
07		17	
06		16	
05		15	
04		14	
03		13	
02		12	
01		11	

PORT NO. 002 <input type="checkbox"/> LCD <input type="checkbox"/>			
LOCATION: 202 omit 20			
Button	Code	Button	Code
10	#000	20	#012
09	*99	19	#01
08	499	18	#010
07	498	17	#009
06	470	16	#008
05	497	15	#007
04	301	14	#006
03	301	13	#004
02	001	12	#003
01	000	11	#001

PORT NO. 014 <input type="checkbox"/> LCD <input type="checkbox"/>			
LOCATION: 214 omit 210			
Button	Code	Button	Code
10	#000	20	#012
09	*99	19	#011
08	499	18	#010
07	498	17	#009
06	470	16	#008
05	497	15	#007
04	301	14	#006
03	301	13	#004
02	301	12	#003
01	000	11	#001

PORT NO. ____ <input type="checkbox"/> LCD <input type="checkbox"/>			
LOCATION:			
Button	Code	Button	Code
10		20	
09		19	
08		18	
07		17	
06		16	
05		15	
04		14	
03		13	
02		12	
01		11	

PORT NO. ____ <input type="checkbox"/> LCD <input type="checkbox"/>			
LOCATION:			
Button	Code	Button	Code
10		20	
09		19	
08		18	
07		17	
06		16	
05		15	
04		14	
03		13	
02		12	
01		11	

PORT NO. ____ <input type="checkbox"/> LCD <input type="checkbox"/>			
LOCATION:			
Button	Code	Button	Code
10		20	
09		19	
08		18	
07		17	
06		16	
05		15	
04		14	
03		13	
02		12	
01		11	

PORT NO. ____ <input type="checkbox"/> LCD <input type="checkbox"/>			
LOCATION:			
Button	Code	Button	Code
10		20	
09		19	
08		18	
07		17	
06		16	
05		15	
04		14	
03		13	
02		12	
01		11	

PORT NO. ____ <input type="checkbox"/> LCD <input type="checkbox"/>			
LOCATION:			
Button	Code	Button	Code
10		20	
09		19	
08		18	
07		17	
06		16	
05		15	
04		14	
03		13	
02		12	
01		11	

PORT NO. ____ <input type="checkbox"/> LCD <input type="checkbox"/>			
LOCATION:			
Button	Code	Button	Code
10		20	
09		19	
08		18	
07		17	
06		16	
05		15	
04		14	
03		13	
02		12	
01		11	

PROGRAMMING PROCEDURES — RECORD SHEETS

SECTION 100-280-303

PROGRAM 40 — STATION CO LINE ACCESS

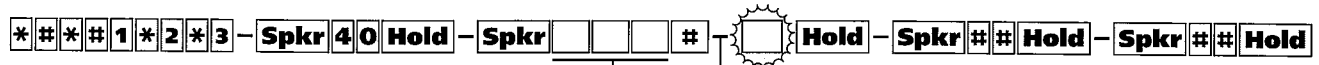

SELECT = Port Numbers

Buttons/LEDs = CO Lines
Light LEDs for the port(s) specified.
See Note 5 LEDs ON/OFF line.

Press: **Scroll** to advance or **Page** to go back⁴

Check Off the Trunk and Port Range Covered by this Record Sheet

CO Line Range	001 ~ 040	041 ~ 080	081 ~ 120	121 ~ 144		
Port Range	000 ~ 039	040 ~ 079	080 ~ 119	120 ~ 159	160 ~ 199	200 ~ 239

Copy this page for more CO lines and ports.

PORTS →	CO Line	LED ↓																		
	20																			
	19																			
	18																			
	17																			
	16																			
	15																			
	14																			
	13																			
	12																			
	11																			
	10																			
	09																			
	08																			
	07																			
	06																			
	05																			
	04																			
	03																			
	02																			
	01																			
	20																			
	19																			
	18																			
	17																			
	16																			
	15																			
	14																			
	13																			
	12																			
	11																			
	10																			
	09																			
	08																			
	07																			
	06																			
	05																			
	04																			
	03																			
	02																			
	01																			

NOTES:

1. Initialized data reads all LEDs ON for all CO lines. Complete CO line access is allowed on all ports.
2. A range of ports may be entered by keying in: *
 Low port in range — High port in range
3. To advance the CO line range, press the **Scroll** button beneath the LCD. Press the **Page** button for a lower range.
4. To turn all CO LEDs on or off, after the port number and **#** is entered, press the **Vol-up** (all LEDs on) or **Vol-down** (all LEDs off). To check a particular CO line, after the port number is entered, press **Mode** and enter the CO line number, then use the **#** button to display and advance.

PROGRAMMING PROCEDURES — RECORD SHEETS

PROGRAM *41-2 — T1 CHANNEL ASSIGNMENTS

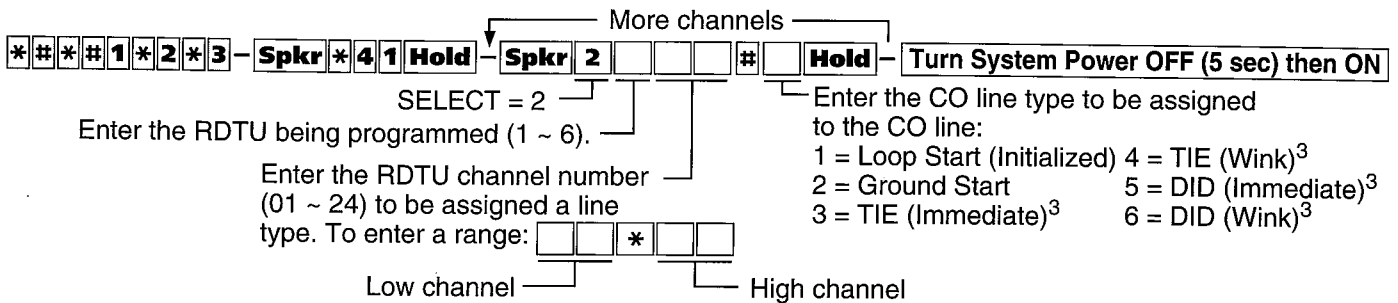

Copy this page for more RDTU assignments.

RDTU (1 ~ 6) _____	
RDTU CHANNEL NO.	LINE TYPE
01	
02	
03	
04	
05	
06	
07	
08	
09	
10	
11	
12	
13	
14	
15	
16	
17	
18	
19	
20	
21	
22	
23	
24	

RDTU (1 ~ 6) _____	
RDTU CHANNEL NO.	LINE TYPE
01	
02	
03	
04	
05	
06	
07	
08	
09	
10	
11	
12	
13	
14	
15	
16	
17	
18	
19	
20	
21	
22	
23	
24	

RDTU (1 ~ 6) _____	
RDTU CHANNEL NO.	LINE TYPE
01	
02	
03	
04	
05	
06	
07	
08	
09	
10	
11	
12	
13	
14	
15	
16	
17	
18	
19	
20	
21	
22	
23	
24	

IMPORTANT NOTES:

1. Turn system power off (5 seconds) and on after running **Program *41-2**.
2. Always install RDTU PCBs that have TIE or DID channels in slot numbers that are higher than station and Attendant Console PCB slot numbers. Each TIE or DID line installed will use a station port in software (see Section 100-280-202, Worksheet 2 for TIE/DID configuration).
3. See Program 17 for other TIE/DID assignments; see Program *17 and *09 for other DID assignments.

PROGRAMMING — RECORD SHEETS

SECTION 100-280-303

PROGRAM *41-3 — T1 SPAN TRANSMIT (SEND) LEVEL PAD ASSIGNMENTS

###1*2*3 - Spkr*41 Hold - Spkr 3 Hold - Spkr## Hold - Spkr## Hold

SELECT = 3
Enter the RDTU being programmed (1 ~ 6).

Enter one of the following pads codes for the transmission path:
 1 = +6 decibel (dB) pad
 2 = +3 dB pad
 3 = 0 dB pad
 4 = -3 dB pad
 5 = -6 dB pad (Initialized: PAD_ S = 5)
 6 = -9 dB pad
 7 = -12 dB pad
 8 = -15 dB pad
 PAD Code

RDTU No.	1	2	3	4	5	6
PAD Code						

PROGRAM *41-4 — T1 SPAN RECEIVE LEVEL PAD ASSIGNMENTS

###1*2*3 - Spkr*41 Hold - Spkr 4 Hold - Spkr## Hold - Spkr## Hold

SELECT = 4
Enter the RDTU being programmed (1 ~ 6).

Enter one of the following pads for the reception path:
 1 = +6 decibel (dB) pad
 2 = +3 dB pad
 3 = 0 dB pad
 4 = -3 dB pad (Initialized: PAD_ R = 4)
 5 = -6 dB pad
 6 = -9 dB pad
 7 = -12 dB pad
 8 = -15 dB pad
 PAD Code

RDTU No.	1	2	3	4	5	6
PAD Code						

PROGRAMMING — RECORD SHEETS

SECTION 100-280-303

PROGRAM 42-0 — CO LINE TO PBX/CENTREX CONNECTION (LINES 1 ~ 80)

##*1*2*3 - Spkr 4 2 Hold - Spkr 0  Hold - Spkr ## Hold - Spkr ## Hold

SELECT = 0

Specify CO lines by setting Button/LEDs as defined by the table below. See Note 3 to change a CO line range.

Press: **Scroll** to advance or **Page** to go back²

Button LED	Line	Set Button LEDs		Button LED	Line	Set Button LEDs	
		CENTREX/PBX Connection (LED ON)	Normal (LED OFF)			CENTREX/PBX Connection (LED ON)	Normal (LED OFF)
20	040			20	080		
19	039			19	079		
18	038			18	078		
17	037			17	077		
16	036			16	076		
15	035			15	075		
14	034			14	074		
13	033			13	073		
12	032			12	072		
11	031			11	071		
10	030			10	070		
09	029			09	069		
08	028			08	068		
07	027			07	067		
06	026			06	066		
05	025			05	065		
04	024			04	064		
03	023			03	063		
02	022			02	062		
01	021			01	061		
20	020			20	060		
19	019			19	059		
18	018			18	058		
17	017			17	057		
16	016			16	056		
15	015			15	055		
14	014			14	054		
13	013			13	053		
12	012			12	052		
11	011			11	051		
10	010			10	050		
09	009			09	049		
08	008			08	048		
07	007			07	047		
06	006			06	046		
05	005			05	045		
04	004			04	044		
03	003			03	043		
02	002			02	042		
01	001			01	041		



NOTES:

1. Initialized data reads all LEDs OFF for all CO lines.
2. To advance the CO line range, press the **Scroll** button beneath the LCD, press the **Page** button for a lower range.
3. To turn all CO LEDs on or off, after the port number code is entered, press the Vol-up (all LEDs on) or Vol-down (all LEDs off). To check a particular CO line, after the port number is entered, press Mode and enter the CO line number, then use the **#** button to display and advance.
4. This program must be utilized to allow CENTREX/PBX (after flash) features to operate.
5. If CO line is programmed for behind CENTREX/PBX (LED ON), reseed guard time is 1.5 seconds. If CO line is programmed for normal operation guard time is 0.45 seconds. See **Program 10-1, Button/LED 02**.

PROGRAMMING — RECORD SHEETS

SECTION 100-280-303

PROGRAM 42-0 — CO LINE TO PBX/CENTREX CONNECTION (LINES 81 ~ 144)

##1*2*3 - Spkr 4 2 Hold - Spkr 0  Hold - Spkr ## Hold - Spkr ## Hold

SELECT = 0

Specify CO lines by setting Button/LEDs as defined by the table below. See Note 3 to change a CO line range.

Press: **Scroll** to advance or **Page** to go back²

Button LED	Line	Set Button LEDs	
		CENTREX/PBX Connection (LED ON)	Normal (LED OFF)
20	120		
19	119		
18	118		
17	117		
16	116		
15	115		
14	114		
13	113		
12	112		
11	111		
10	110		
09	109		
08	108		
07	107		
06	106		
05	105		
04	104		
03	103		
02	102		
01	101		
20	100		
19	099		
18	098		
17	097		
16	096		
15	095		
14	094		
13	093		
12	092		
11	091		
10	090		
09	089		
08	088		
07	087		
06	086		
05	085		
04	084		
03	083		
02	082		
01	081		

Button LED	Line	Set Button LEDs	
		CENTREX/PBX Connection (LED ON)	Normal (LED OFF)
20	140		
19	139		
18	138		
17	137		
16	136		
15	135		
14	134		
13	133		
12	132		
11	131		
10	130		
09	129		
08	128		
07	127		
06	126		
05	125		
04	124		
03	123		
02	122		
01	121		

Button LED	Trunk	Set Button LEDs	
		CENTREX/PBX Connection (LED ON)	Normal (LED OFF)
04	144		
03	143		
02	142		
01	141		

NOTES:

1. Initialized data reads all LEDs OFF for all CO lines.
2. To advance the CO line range, press the **Scroll** button beneath the LCD, press the **Page** button for a lower range.
3. To turn all CO LEDs on or off, after the port number code is entered, press the Vol-up (all LEDs on) or Vol-down (all LEDs off). To check a particular CO line, after the port number is entered, press Mode and enter the CO line number, then use the  button to display and advance.
4. This program must be utilized to allow CENTREX/PBX (after flash) features to operate.
5. If CO line is programmed for behind CENTREX/PBX (LED ON), reseize guard time is 1.5 seconds. If CO line is programmed for normal operation guard time is 0.45 seconds. See **Program 10-1, Button/LED 02**.

PROGRAMMING — RECORD SHEETS

SECTION 100-280-303

PROGRAM 42-1 ~ 8 — PBX/CENTREX ACCESS CODES

##1*2*3 - Spkr 4 2 Hold - Spkr - - Hold - Spkr ## Hold - Spkr ## Hold

SELECT = 1 ~ 8 PBX Access Code Group
Enter the PBX Group Number 1 ~ 8 that needs an access code assigned.

ACCESS CODE = Enter a 2-digit access code for the group, as defined by the table below. See Note 3.

PBX/CENTREX Access Code Number	PBX/CENTREX Outgoing CO Line Access Code(s)	
	1st digit	2nd digit
1	9	
2		
3		
4		
5		
6		
7		
8		

NOTES:

1. For more information, see the instructions preceding the record sheets.
2. Initialized data assigns no access codes to PBX groups.
3. • If access code is single digit, enter the first digit and press Button/LED 01 as second digit.
 - Press Button/LED 01 to delete a digit.
 - Press Button/LED 02 for don't care. For example, pressing **8** + Button/LED 02 allows 80 ~ 89.
4. This program must be utilized to allow correct Toll Restriction and CENTREX/PBX transfer operation.

PROGRAM *42-1 — T1 SPAN PRIMARY REFERENCE ASSIGNMENTS

• Primary Clock Reference T1 PCB assignment

##1*2*3 - Spkr *42 Hold - Spkr 1 - Hold - Spkr ## Hold - Spkr ## Hold

Primary T1 (1 ~ 6)
 Initialized Data = 1

Enter the RDTU PCB number (1 ~ 6)¹ that is connected to the primary reference T1 (span line) clock source². Press key 01 (Blank) if the DK280 T1 is the master (free run) clock source³

PROGRAM *42-2 — T1 SPAN AND SECONDARY CLOCK SOURCE REFERENCE ASSIGNMENTS

• Secondary (Back-up) Reference T1 PCB assignment

##1*2*3 - Spkr *42 Hold - Spkr 2 - Hold - Spkr ## Hold - Spkr ## Hold

Secondary T1 (1 ~ 6)
 Initialized Data = 2

Enter the RDTU PCB number (1 ~ 6)¹ that is connected to the back-up reference T1 (span line) clock source². Press key 01 (Blank) if the DK280 T1 is the master (free run) clock source³

NOTES:

1. RDTU No.1 is the RDTU PCB installed in the lowest slot number of all RDTU PCBs, RDTU No. 2 is the RDTU PCB installed in the next highest slot number of all RDTUs and so on.
2. Example of Primary/Back-Up assignments:

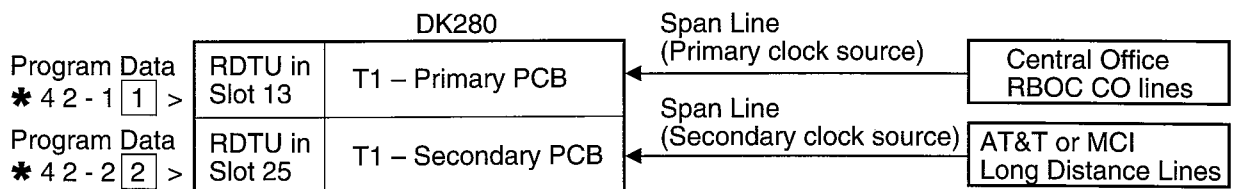

NOTE:
 A second RBOC T1 span line can also be used as the secondary clock source.

3. Example of DK280 Master (free run) assignment:

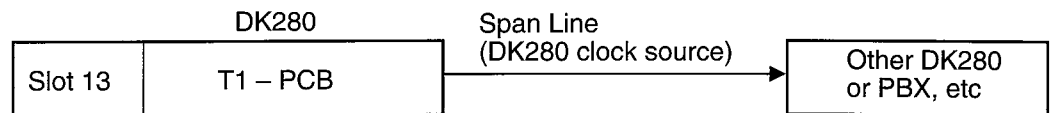

Program Data = blank key (Key 01) for
 * 42 - 1 and * 42 - 2

PROGRAM 44-91 ~ 93 — EMERGENCY BYPASS OF FORCED/VERIFIED ACCOUNT CODES

##1*2*3 - Spkr 44 Hold Spkr [] [] - [] [] [] [] Hold - Spkr ## Hold - Spkr ## Hold

SELECT = 91 ~ 93
to set Emergency
Number 1 ~ 3

DATA = 3- or 4-digit emergency
telephone number
To enter blanks,
Press: Button/LED 01

Example:

Emergency Number 1: [9] [1] [9] [1] [1] []

911 = Initialized Data

Emergency Number 2: [9] [2] [] [] [] []

9911 (Note 2)

Emergency Number 3: [9] [3] [] [] [] []

SELECT = [] DATA = 3- or 4-digit telephone number

NOTES:

1. The emergency telephone numbers assigned in this program will be sent out to the CO line immediately when dialed; they will bypass the Forced/Verified Account Code dialing restriction.
2. If CO lines are behind PBX or CENTREX, program the PBX/CENTREX outside CO line access code: Example: "9". A pause is automatically inserted following the first 9. See **Programs 42-0** and **42-1** to assign the CO line and access code for behind PBX/CENTREX operation. Also, if the system CO lines are behind CENTREX/PBX, the CENTREX/PBX CO line access codes must be programmed in front of the emergency telephone number. Example: If the CENTREX/PBX access code is "9", then enter 9911 in **Program 44-91 ~ 93**.
3. If Verified Account Codes assigned in **Program 69** conflict (are the same) with emergency telephone numbers assigned in **Program 44-91 ~ 93**; **Program 44-91 ~ 93** has priority.
4. This feature is for use with Forced (Verified or Nonverified) Account Codes, but not with ABR and DISA. It also does not override Toll Restriction; emergency numbers must be allowed using system Toll Restriction tables per normal Toll Restriction programming procedures.
5. **Program 44-1 ~ 8** is related to Toll Restriction and is placed with the other Toll Restriction programs in this chapter.

Programs 44-1 ~ 8 through 48 can be found in the
Toll Restriction System Record section.

Programs 50 through 56 can be found in the
Least Cost Routing System Record section.

PROGRAMMING — RECORD SHEETS

SECTION 100-280-303

PROGRAM 58-1 — ATTENDANT CONSOLE OVERFLOW TIMER⁴

##1*2*3 - Spkr 58 Hold - Spkr 1 - - Hold - Spkr ## Hold - Spkr ## Hold

Data = 011 ~ 999 seconds

Data =

NOTES:

1. Initialized Data = 032 seconds.
2. This program sets overflow timer for all attendant consoles (1~4).
3. The overflow destination is assigned in Program 58-5.
4. Use with RCTUB2 or RCTUC/RCTUD2 Release 2 or above only.

PROGRAM 58-2 — ATTENDANT CONSOLE DISPLAY TYPE (see Note)

##1*2*3 - Spkr 58 Hold - Spkr 2 Key 01/02 - Hold - Spkr Spkr ## Hold - Spkr ## Hold

Console number (1 ~ 4)

Key LED 01 ON for EL; or, OFF for EGA display
Initial Data = OFF/EGA

Key LED 02 set Answer Key operation for First In / First Out (FIFO) or priority per Program 58-4

Key LED 03 Attd Console Call Waiting Tone

Attendant Console	Key 01 LED		Key 02 LED		Key 03 LED	
	ON (EL)	OFF (EGA)	ON (FIFO)	OFF (58-4)	ON (Call Waiting Tone)	OFF (No Call Waiting Tone)
1						
2						
3						
4						

NOTE: Use with RCTUB2 or RCTUC/RCTUD2 Release 2 or above only.

PROGRAM 58-4 — ATTENDANT CONSOLE ANSWER KEY PRIORITY ASSIGNMENTS³

##1*2*3 - Spkr 58 Hold - Spkr 4 - - Hold - Spkr ## Hold - Spkr ## Hold

Highest priority ————— Lowest priority

Console number (1 ~ 4)

Enter key numbers in priority order

Key Name	Trans RC	Hold-RC	In-Trans	LINE	In Dial "0"	Intercom
Key Number	1	2	3	4	5	6

NOTES:

1. EMRG has first priority over the above key assignments.
2. See Program 59 for the function of each key.
3. Use with RCTUB2 or RCTUC/RCTUD2 Release 2 or above only.

PROGRAM 58-5 — ATTENDANT CONSOLE OVERFLOW DESTINATION ASSIGNMENT³

###1*2*3 - Spkr 5 8 Hold - Spkr 5 - - Hold - Spkr ## Hold - Spkr ## Hold

Console number (1 ~ 4)

Enter the overflow destination port number (000 ~ 239)

Console overflow destination =

NOTES:

1. Calls that will overflow include ring transfer, CO line incoming, dial "0", and INT calls; Ring Transfer recall and Hold recall will not overflow.
2. Overflow recall time is set in Program 58-1.
3. Use with RCTUB2 or RCTU C/D Release 2 or above only.

PROGRAM 59 — ATTENDANT CONSOLE FLEXIBLE BUTTON CODES (Note)

Table A – Function and Incoming Call Identification (ICI) Button Codes

(See page 3-72 to enter Program 59 button labels)

BUTTON FUNCTION	BUTTON LABELS	CODE	NOTES	BUTTON FUNCTION	BUTTON LABELS	CODE	NOTES
Out Dial	Out Dial	294	Switches ATTD consoles dial pad from digital to tone mode	Split Call	Split	295	Allows attendant to talk to either party separately on a conference call
Display BLF	BLF	298	Displays BLF on CRT or EL display	Incoming Dial "0"	In-Dial "0"	262	Dial "0" calls ring in on this button
Conference	Conf	297	Starts conference calls	Incoming Emergency	In-Emrg	261	Emergency calls ring in on this button (Int #400)
Join-Loop	Join-Loop	293	Connects any held call to an existing call.	Transfer Recall	Trans-RC	260	No answer transferred calls, recall on this button
Overflow	Overflow	299	Places console in the call overflow mode	Hold Recall	Hold-RC	259	Held calls recall on this button
Supervised Loop	Sup Loop	296	Places call on attendant hold loop key so attendant can supervise call	Incoming Ring Transfer	In-Trans	258	Receive call transfer
Emergency Page Access	Emrg Page	292	Activates ALL CALL Paging to telephone speakers (not EXTR Page). Overrides any existing ALL CALL page.	Intercom	Intercom	257	Incoming intercom calls ring on this button. Can make Intercom calls on this button. Intercom LED is lit red any time the attendant talk path is connected.

Table B – Incoming Line Group (LG) Button Codes²

INCOMING LINE GROUP BUTTON ASSIGNMENTS	In-LG1 ~ 241	In-LG5 ~ 245	In-LG9 ~ 249	In-LG13 ~ 253
	In-LG2 ~ 242	In-LG6 ~ 246	In-LG10 ~ 250	In-LG14 ~ 254
	In-LG3 ~ 243	In-LG7 ~ 247	In-LG11 ~ 251	In-LG15 ~ 255
	In-LG4 ~ 244	In-LG8 ~ 248	In-LG12 ~ 252	In-LG16 ~ 256

- NOTE:**
1. Use with RCTUB2 or RCTUC/RCTUD2 Release 2 or above only.
 2. Only assign one In-LG button per group per console. Only one In-LG button can be active on each console.

PROGRAM 59 — ATTENDANT CONSOLE FLEXIBLE BUTTON CODES (continued)³

TABLE C – Miscellaneous Attendant Console/Telephone Button Codes

Button Function	Button Labels	Code	Notes	Button Function	Button Labels	Code	Notes
Account Code	Account Code or ACCOUNT	450	Allows a Voluntary Account Code to be entered	Door Lock 1 thru Door Lock 4 (DDCB/HDCB)	Unlock Door 1 or DRLK 1	472	Momentarily unlocks door (3 or 6 sec.) See Prog 77-1 and 77-2
Alarm	Alarm Reset or ALRM	477	Resets alarm condition system wide		Unlock Door 2 or DRLK 2	473	
All Call Voice Page	All Call Page or AC	489	Pages all idle electronic/digital telephones over speaker		Unlock Door 3 or DRLK 3	474	
Automatic Busy Redial	Auto Busy Redial or ABR	470	Sets ABR of busy outgoing number		Unlock Door 4 or DRLK 4	475	
Automatic Callback Busy	Auto Callback or ACB	494	Sets ACB for station recalled by busy line	Intercom	Intercom or INT	000	Intercom line access key
Background Music	Tel Set Music or BGM	478	Turns BGM ON or OFF through station speaker	LCD Message	MSG	481	Begins LCD message selection
Call Forward All Calls	Call Frwd All Calls or CFAC	487	All calls forward to selected station	Message Waiting and Flash	Flash or MW/FL	499	Provides message waiting LED for EKT and Flash key
Call Forward A.C. Fixed	Call Frwd to: or CFF	486	Forwards all calls to pre-defined destination. See Program 36	Night Transfer Tenant 1	Night Transfer 1 or NT1	439	Sets Tenant 1 CO line DAY/NIGHT ringing mode
Call Forward Busy	Call Frwd Busy or CFB	459	Forwards calls to selected station if station is busy	Night Transfer Tenant 2	Night Transfer 2 or NT2	440	Sets Tenant 2 CO line DAY/NIGHT ringing mode
Call Forward Busy/No Answer	Call Frwd Busy/NAns or CFB/NA	457	Forwards calls to selected station if station is busy or does not answer	Night Transfer Tenant 3	Night Transfer 3 or NT3	441	Sets Tenant 3 CO line DAY/NIGHT ringing mode
Call Forward External	CF-EXT	460	Forward calls externally	Night Transfer Tenant 4	Night Transfer 4 or NT4	442	Sets Tenant 4 CO line DAY/NIGHT ringing mode
Call Forward No Answer	Call Frwd No Answer or CFNA	458	Forwards calls to selected station if station does not answer	Pause	Spd Dial Pause or PAU	495	Sets pause in Speed Dial. See Program 12-3
Call Pickup (Directed)	Directed Pickup or PKUP	484	Picks up ringing or held intercom, trunk calls, and page	Pause (Long)	Spd Dial Lng Pause or PAU/L	493	Sets a 10-second pause in Speed Dial
Call Pickup Tenant 4	PKUP 4	435	Picks up tenant 4's ringing CO calls	Pooled Line	Pooled Line Grp or PL	301 ~ 316	Multiple CO line may appear under one key
Call Pickup Tenant 3	PKUP 3	436	Picks up tenant 3's ringing CO calls	Privacy	Privacy On Line or PRIVACY	453	Prevents Privacy Override (not Exc. Over.)
Call Pickup Tenant 2	PKUP 2	437	Picks up tenant 2's ringing CO calls	Privacy Release	Privacy Release or PRV RLS	479	Changes station Privacy mode to Non-private for CO line
Call Pickup Tenant 1	PKUP 1	438	Picks up tenant 1's ringing CO calls	Redial Last Number (# Key)	RDL (EKT only)	496	Redials the last number
Call Pickup (Group)	Group Pickup	480	Pick up a call to any group to which station is assigned in *31	Release	Release Call or RLS	476	Releases current call and makes station idle
CO line Appearance	Line 1 ~ 144 or CO 001 ~ CO 144	000 ~ 144	CO line access of appearing calls	Save Last Number	Save Last Number or SAVE	485	Saves last number dialed for future speed dial
Direct Station Selection	DSS	#000~ #239	Assigns DSS hotline keys to port number	Speed Dial Select (* Key)	Speed Dial or SDS	497	Begins speed dial selection
Do Not Disturb	Do Not Disturb or DND	498	Prevents calls to station	Station/Console Speed Dial Codes	SD	*010~ *049	Reserves key for station speed dial
Door Lock 0	Unlock Door 0 or DRLK 0	471	Momentarily unlocks door (3 or 6 sec.) PIOUS/PIOU/PEPU	System Speed Dial Codes	SD ¹	*600~ *699 or *60~ *99	Speed dial number set by station port 000
				Tone	Tone Dial Select or TONE	490	CO dial signals set to tone or pulse

NOTES:

1. RCTU A provides 40 system speed dial numbers (60 ~ 99). RCTU B or RCTUB2 and RCTUC/RCTUD2 or RCTUD provide 100 (600 ~ 699).
2. See Program 39 record sheet for more notes about the above button functions.
3. Use with RCTUB2 or RCTU C/D2 Release 2 or above only.

PROGRAMMING — RECORD SHEETS

SECTION 100-280-303

PROGRAM 59 — ATTENDANT CONSOLE FLEXIBLE BUTTON CODES (continued) (see Note)

###1*2*3 - Spkr - 59 - - - - - - Hold - Spkr## Hold - Spkr## Hold

Attendant Console (1~4)

1 = Left, 2 = Right

Data = Button Code (3-digits)

(See tables A, B, and C on previous pages)

Press Key 01~12 on Programming Telephone to enter data for corresponding console key.

Copy as required for more consoles

Attendant Console No. _____

Left (Keys 1~12)			Right (Keys 1~12)		
10	11	12	10	11	12
07	08	09	07	08	09
04	05	06	04	05	06
01	02	03	01	02	03

Attendant Console No. _____

Left (Keys 1~12)			Right (Keys 1~12)		
10	11	12	10	11	12
07	08	09	07	08	09
04	05	06	04	05	06
01	02	03	01	02	03

Initialized Data:

Left (Keys 1 ~ 12)			Right (Keys 1 ~ 12)		
Split (295)	Join-Loop (293)	Sup. LOOP (296)	Conf (297)	Overflow (299)	Night (439)
In-Emerg (261)	In-Int (257)	In-Dial "0" (262)	Redial (496)	Spdial (497)	SD13 (★13)
In-Trans (258)	Trans-RC (260)	Hold-RC (259)	BLF (298)	Out Dial (294)	SD12 (★12)
In-LG3 (243)	In-LG2 (242)	In-LG1 (241)	Intercom (000)	Hold/Page (★10) ² (HI #39)	SD11 (★11)

NOTE: 1. Use with RCTUB2 or RCTU C/D Release 2 or above only.

2. It is recommended to set the Auto Hold/Page function (Hold + Int + #39) on speed dial *10 button or any other flexible speed dial button on the Attendant Console.

PROGRAM 60 (2~7) — SMDR OUTPUT/ACCOUNT CODE DIGIT LENGTH

##*1*2*3 - Spkr 6 0 Hold - Spkr [] [] [] [] - Hold - Spkr ## Hold - Spkr ## Hold

SELECT = 2 ~ 7 (Item)
Make a selection to indicate which item is being assigned.

For "2" SMDR TIME = 0 or 1

Enter 0 to indicate 1 second threshold time.
Enter 1 to indicate 10 second threshold time.

For "3" SMDR COR = 0 or 1 (Data)

Enter one digit to indicate SMDR output operation.
0 = No Incoming Record
1 = Incoming and Outcoming Record

For "4" ACCOUNT = 04 ~ 15

Enter the number of digits allowed for Forced/Voluntary Account Codes. The range is 04 ~ 15. Enter two digits.

For "5" TOLL DIAL

Enter one digit (the range is 0 ~ 5).

For "6" DISA SECURITY CODE 01 ~ 15 DIGITS

For "7" CREDIT CARD DIGITS

Item	Description	Data
2	SMDR Threshold Time ¹¹ 0 = 1 second 1 = 10 seconds	TIME <input type="checkbox"/>
3	SMDR Output when a call is completed. 0 = Outgoing Only 1 = Incoming and Outgoing	(SMDR COR) <input type="checkbox"/>
4	⁹ Forced/Voluntary Account Code Digit Length 04 ~ 15. (Digits are verified per Prog. 30 , Button/LED 14, and Prog. 69)	(ACCOUNT) <input type="checkbox"/> <input type="checkbox"/>
5	SMDR Printout options Toll Dial = <input type="checkbox"/> All Calls (Note 6) = <input type="checkbox"/> Dial "0" calls only = <input type="checkbox"/> Dial "1" calls only = <input type="checkbox"/> Dial "00" calls only = <input type="checkbox"/> Dial "1", "0", calls only = <input type="checkbox"/> Dial "1" or "00" calls only	(TOLL DIAL DATA) <input type="checkbox"/>
6	DISA Security Code ⁸ (01 ~ 15 digits, may be changed from station, per Program 30)	DATA <input type="checkbox"/> ~ <input type="checkbox"/>
7	Credit card call digit length, 01 ~ 30 ¹² digits (see Program 43)	CREDIT ¹⁰ <input type="checkbox"/> <input type="checkbox"/>

NOTES:

1. For Selection 3, initialized data assigns SMDR output to be enabled for incoming/outgoing calls that are answered.
2. For Selection 4, initialized data assigns a 6-digit length to all Forced/Voluntary Account Codes.
3. If PBX code is dialed, numbers dialed after the code will be checked.
4. If A/C, O/C or SPCC code begins with "0", "1", or "00", that call will print out.
5. When accessing LCR feature, all digits sent to CO will be output.
6. Selection 3 (printout outgoing call only) is still available.
7. Button/LED 1 = blank, Button/LED 2 = don't care.
8. If a security code is not programmed, outgoing trunk access via DISA will not require a security code when dialing.
9. See **Program 69** for Verified Account Codes.
10. Number of digits required when "0" is the first digit dialed; if this number of digits is not dialed, the system will disconnect the call after 20 seconds. "0" is counted as a digit. **Example:** 0 + 1 + 714 + 583 - 3700 = 12 digits; 12 should be programmed as a minimum in this case.
11. Default is 10 seconds.
12. Default is 21-digits.

PROGRAMMING — RECORD SHEETS

SECTION 100-280-303

PROGRAM 69 — VERIFIED ACCOUNT CODES

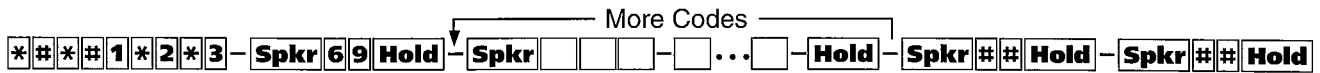

Check VACN Range	
000 ~ 024	
100 ~ 124	
200 ~ 224	

SELECT = Verified Account Code Number (VACN)

Verified Account Code (1 ~ 15 digits)

Copy as required.

NAME	VACN (3-Digit)	VERIFIED ACCOUNT CODE (1 ~ 15 DIGITS)														
		1	2	3	4	5	6	7	8	9	10	11	12	13	14	15
	_00															
	_01															
	_02															
	_03															
	_04															
	_05															
	_06															
	_07															
	_08															
	_09															
	_10															
	_11															
	_12															
	_13															
	_14															
	_15															
	_16															
	_17															
	_18															
	_19															
	_20															
	_21															
	_22															
	_23															
	_24															

NOTES:

- Account code format
 - Account Code digit length is defined in **Program 60-4** (4 ~ 15 digits).
 - To dial an Account Code, station users must always dial the quantity of digits defined in **Program 60-4**.
 - If the quantity of digits in a Verified Account Code is the same as the Account Code digit length in **Program 60-4**, then all digits will be Verified; if the quantity of digits are less, then only those digits will be verified.
- Account Codes may not conflict (be the same as) emergency numbers in **Program 44A**.

PROGRAMMING — RECORD SHEETS

PROGRAM 69 — VERIFIED ACCOUNT CODES (continued)

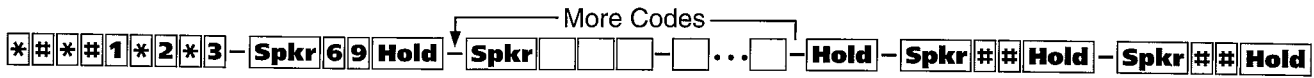

Check VACN Range	
025 ~ 049	
125 ~ 149	
225 ~ 249	

SELECT = Verified Account Code Number (VACN)

Verified Account Code (1 ~ 15 digits)

Copy as required.

NAME	VACN (3-Digit)	VERIFIED ACCOUNT CODE (1 ~ 15 DIGITS)														
		1	2	3	4	5	6	7	8	9	10	11	12	13	14	15
	_25															
	_26															
	_27															
	_28															
	_29															
	_30															
	_31															
	_32															
	_33															
	_34															
	_35															
	_36															
	_37															
	_38															
	_39															
	_40															
	_41															
	_42															
	_43															
	_44															
	_45															
	_46															
	_47															
	_48															
	_49															

NOTES:

- Account code format
 - Account Code digit length is defined in **Program 60-4** (4 ~ 15 digits).
 - To dial an Account Code, station users must always dial the quantity of digits defined in **Program 60-4**.
 - If the quantity of digits in a Verified Account Code is the same as the Account Code digit length in **Program 60-4**, then all digits will be Verified; if the quantity of digits are less, then only those digits will be verified.
- Account Codes may not conflict (be the same as) emergency numbers in **Program 44A**.

PROGRAMMING — RECORD SHEETS

PROGRAM 69 — VERIFIED ACCOUNT CODES (continued)

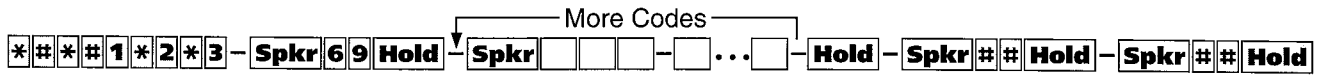

Check VACN Range	
050 ~ 074	
150 ~ 174	
250 ~ 274	

SELECT = Verified Account Code Number (VACN)

Verified Account Code (1 ~ 15 digits)

Copy as required.

NAME	VACN (3-Digit)	VERIFIED ACCOUNT CODE (1 ~ 15 DIGITS)														
		1	2	3	4	5	6	7	8	9	10	11	12	13	14	15
	_50															
	_51															
	_52															
	_53															
	_54															
	_55															
	_56															
	_57															
	_58															
	_59															
	_60															
	_61															
	_62															
	_63															
	_64															
	_65															
	_66															
	_67															
	_68															
	_69															
	_70															
	_71															
	_72															
	_73															
	_74															

NOTES:

- Account code format
 - Account Code digit length is defined in **Program 60-4** (4 ~ 15 digits).
 - To dial an Account Code, station users must always dial the quantity of digits defined in **Program 60-4**.
 - If the quantity of digits in a Verified Account Code is the same as the Account Code digit length in **Program 60-4**, then all digits will be Verified; if the quantity of digits are less, then only those digits will be verified.
- Account Codes may not conflict (be the same as) emergency numbers in **Program 44A**.

PROGRAMMING — RECORD SHEETS

PROGRAM 69 — VERIFIED ACCOUNT CODES (continued)

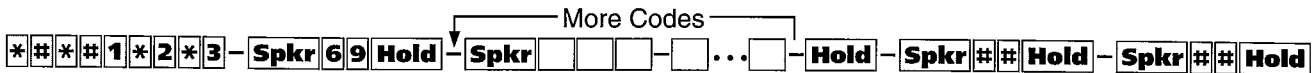

Check VACN Range	
075 ~ 099	
175 ~ 199	
275 ~ 299	

SELECT = Verified Account Code Number (VACN)

Verified Account Code (1 ~ 15 digits)

Copy as required.

NAME	VACN (3-Digit)	VERIFIED ACCOUNT CODE (1 ~ 15 DIGITS)														
		1	2	3	4	5	6	7	8	9	10	11	12	13	14	15
	_75															
	_76															
	_77															
	_78															
	_79															
	_80															
	_81															
	_82															
	_83															
	_84															
	_85															
	_86															
	_87															
	_88															
	_89															
	_90															
	_91															
	_92															
	_93															
	_94															
	_95															
	_96															
	_97															
	_98															
	_99															

NOTES:

1. Account code format
 - Account Code digit length is defined in **Program 60-4** (4 ~ 15 digits).
 - To dial an Account Code, station users must always dial the quantity of digits defined in **Program 60-4**.
 - If the quantity of digits in a Verified Account Code is the same as the Account Code digit length in **Program 60-4** then all digits will be Verified; if the quantity of digits are less, then only those digits will be verified.
2. Account Codes may not conflict (be the same as) emergency numbers in **Program 44A**.

PROGRAMMING — RECORD SHEETS

SECTION 100-280-303

PROGRAM 70 — VERIFIED ACCOUNT CODE TOLL RESTRICTION ASSIGNMENTS

##1*2*3 - Spkr 70 Hold - Spkr [] [] [] - [] [] [] - Hold - Spkr ## Hold - Spkr ## Hold

SELECT = Verified
Account Code Number
(VACN) 000 ~ 299

DATA = VAC
Digit Restriction
Code 0 or 1
Enter 0 for no
digit restriction.
Enter 1 for digit
restriction.

VAC Restrict Code (00 ~ 06)
Enter 00 for No Station Toll Restriction.
Enter 01 for Area Code Toll Restriction.
Enter 02 for Area Code Toll Restriction
and 0 or 1 as 1st or 2nd digit.
Enter 03 for Class 1 T.R. Enter 07 for Class 5⁴
Enter 04 for Class 2 T.R. Enter 08 for Class 6⁴
Enter 05 for Class 3 T.R. Enter 09 for Class 7⁴
Enter 06 for Class 4 T.R. Enter 10 for Class 8⁴

Check VACN Range	
000 ~ 099	
100 ~ 199	
200 ~ 299	

Copy as required.

VACN	VAC Digit Restrict Code	VAC Restrict Code
_00		
_01		
_02		
_03		
_04		
_05		
_06		
_07		
_08		
_09		
_10		
_11		
_12		
_13		
_14		
_15		
_16		
_17		
_18		
_19		
_20		
_21		
_22		
_23		
_24		
_25		
_26		
_27		
_28		
_29		
_30		
_31		

VACN	VAC Digit Restrict Code	VAC Restrict Code
_32		
_33		
_34		
_35		
_36		
_37		
_38		
_39		
_40		
_41		
_42		
_43		
_44		
_45		
_46		
_47		
_48		
_49		
_50		
_51		
_52		
_53		
_54		
_55		
_56		
_57		
_58		
_59		
_60		
_61		
_62		
_63		

VACN	VAC Digit Restrict Code	VAC Restrict Code
_64		
_65		
_66		
_67		
_68		
_69		
_70		
_71		
_72		
_73		
_74		
_75		
_76		
_77		
_78		
_79		
_80		
_81		
_82		
_83		
_84		
_85		
_86		
_87		
_88		
_89		
_90		
_91		
_92		
_93		
_94		
_95		
_99		

NOTES:

1. Initialized data reads 00 for all VACNs.
2. This restriction overrides the normal station restriction assigned in **Program 48** when a VAC is entered at the station. The station resumes its **Program 48** restriction after the call is disconnected.
3. Range programming is not available.
4. RCTUA and B provide Classes 1 ~ 4, RCTU C/D provide Classes 1 ~ 8.

PROGRAMMING — RECORD SHEETS

SECTION 100-280-303

PROGRAM 77-1 — PERIPHERAL OPTIONS (DOOR PHONES/IMDU/PIOU/PIOUS/PEPU)

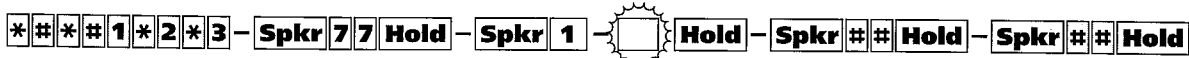

SELECT = 1 — LED/Button
 Light the Buttons/LEDs that are marked with an X in the table below.

LED/ Button	X	LED ON	LED OFF
20		Door Lock Time/6 sec.	Door Lock Time/3 sec.
19 ^{3,7}		Port 028/DDCB4 or ³ HDCB 4	Port 028/Telephone
18 ^{3,7}		Port 020/DDCB3 or ³ HDCB 3	Port 020/Telephone
17 ^{3,7}		Port 012/DDCB2 or ³ HDCB 2	Port 012/Telephone
16 ^{3,7}		Port 004/DDCB1 or ³ HDCB 1	Port 004/Telephone
15		—	—
14		IMDU Modem (Station #19)/Enabled ⁴	IMDU Modem (Station #19)/Disabled
10		Enable 280 ADMIN	Disable 280 ADMIN
08		Door Phone Ring on Ext Page ⁵	No Ring over Ext Page
07		Door Lock Relay Enabled ⁶	External Page Relay Enabled ⁶
06		NT Relay with NT1 or NT2 Button and ringing CO line. ⁸	NT Relay Steady with NT1 Button
05		MOH Relay Enabled	NT Relay Enabled
04		—	—
03		—	—
02		—	—
01		—	—

NOTES:

1. For more information, see the instructions preceding the record sheets.
2. Initialized data leaves all LEDs OFF.
3. DDCB/HDCB = Door Phone/Lock Control Unit. Up to four DDCBs/HDCBs may be installed in a system with RCTU B and C/D, only 3 are allowed with RCTU A. They must be assigned a PDKU, RDSU, PEKU or PESU port number to operate (DDCB to PDKU or RDSU, and HDCB to PEKU or PESU).
4. If a modem unit (IMDU) is installed on a PIOU or PIOUS, it can be accessed by dialing Station #19 and can be assigned a DID extension number in **Program *09**.
5. The door phone will ring over external page if the DK system is in the NIGHT mode.
6. This option applies to the PIOU/PIOUS/PEPU Door Lock Control 0 assigned to electronic or digital telephone buttons using Code 471 in **Program 39**; it does not apply to DDCB or HDCB Door Lock Control.
7. Station PCBs that are connected to HDCB/DDCB doorphones control boxes, must be installed in lower slot numbers than TIE, DID, or Attendant Console PCBs.
8. CO lines must be assigned to night ring over External Page (Program 78-1) to allow the NT relay to operate when CO lines ring incoming.

PROGRAMMING — RECORD SHEETS

SECTION 100-280-303

PROGRAM 77-2 — DOOR PHONE BUSY SIGNAL/DOOR LOCK ASSIGNMENTS

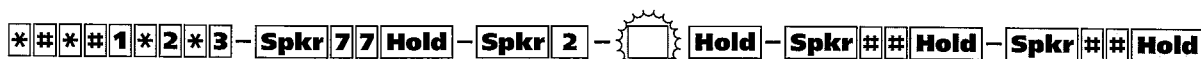

SELECT = 2

LED/Button
Light the LEDs marked with an X in the table below.

LED Key	X	LED ON	LED OFF
20		One Door Phone Ring	Five Door Phone Rings
19		—	—
18		—	—
17		—	—
16		DDCB4/HDCB4 B-jack is Lock Control #4	B is connected to Door Phone 4B
15		Door phone 4C Busy Out	No Busy Signal
14		Door phone 4B Busy Out	No Busy Signal
13		Door phone 4A Busy Out	No Busy Signal
12		DDCB3/HDCB3 B-jack is Lock Control #3	B is connected to Door Phone 3B
11		Door phone 3C Busy Out	No Busy Signal
10		Door phone 3B Busy Out	No Busy Signal
09		Door phone 3A Busy Out	No Busy Signal
08		DDCB2/HDCB2 B-jack is Lock Control #2	B is connected to Door Phone 2B
07		Door phone 2C Busy Out	No Busy Signal
06		Door phone 2B Busy Out	No Busy Signal
05		Door phone 2A Busy Out	No Busy Signal
04		DDCB1/HDCB1 B-jack is Lock Control #1	B is connected to Door Phone 1B
03		Door phone 1C Busy Out	No Busy Signal
02		Door phone 1B Busy Out	No Busy Signal
01		Door phone 1A Busy Out	No Busy Signal

NOTES:

1. For more information, see the instructions preceding the record sheets.
2. Initialized data reads all LEDs OFF.

DDCB and HDCB Port Assignments

DDCB/HDCB Slot No.	Port No.
11	004
12	012
13	020
14	028

PROGRAM 77-3 — NIGHT RINGING OVER TENANT EXTERNAL PAGE ZONES

##1*2*3 - Spkr 77 Hold - Spkr 3 Hold - Spkr## Hold - Spkr## Hold

SELECT = 3
 Enter a PIOU external
 page zone relay (1 ~ 4).

Enter the tenant (1 ~ 4) to be
 assigned with the zone entered
 in the preceding step.²

TENANT	ZONE 1	ZONE 2	ZONE 3	ZONE 4
TENANT 1 CO Lines				
TENANT 2 CO Lines				
TENANT 3 CO Lines				
TENANT 4 CO Lines				

NOTES:

1. Initialized all zones (1-4) assigned to tenant 1.
2. These assignments apply to ground and loop start lines only, they do not apply to DID and TIE lines.

PROGRAM 79 — DOOR PHONE RINGING

##*#1*2*3 - Spkr 7 9 Hold - Spkr # -  Hold - Spkr ## Hold - Spkr ## Hold

SELECT = Port Number
Enter the port number having
Door Phone Ringing assigned.

Buttons/LEDs
Select buttons indicated in the table below.

Select Port Range	
000 ~ 039	120 ~ 159
040 ~ 079	160 ~ 199
080 ~ 119	200 ~ 239

Copy this page for more ports.

Feature	PORTS →																		
	LED ↓																		
Muted ring to busy DKT/EKT	20																		
	19																		
	18																		
	17																		
	16																		
	15																		
	14																		
	13																		
Door phone 4C Ring	12																		
Door phone 4B Ring	11																		
Door phone 4A Ring	10																		
Door phone 3C Ring	09																		
Door phone 3B Ring	08																		
Door phone 3A Ring	07																		
Door phone 2C Ring	06																		
Door phone 2B Ring	05																		
Door phone 2A Ring	04																		
Door phone 1C Ring	03																		
Door phone 1B Ring	02																		
Door phone 1A Ring	01																		

Select Port Range	
000 ~ 039	120 ~ 159
040 ~ 079	160 ~ 199
080 ~ 119	200 ~ 239

Feature	PORTS →																		
	LED ↓																		
Muted ring to busy DKT/EKT	20																		
	19																		
	18																		
	17																		
	16																		
	15																		
	14																		
	13																		
Door phone 4C Ring	12																		
Door phone 4B Ring	11																		
Door phone 4A Ring	10																		
Door phone 3C Ring	09																		
Door phone 3B Ring	08																		
Door phone 3A Ring	07																		
Door phone 2C Ring	06																		
Door phone 2B Ring	05																		
Door phone 2A Ring	04																		
Door phone 1C Ring	03																		
Door phone 1B Ring	02																		
Door phone 1A Ring	01																		

NOTES:

1. Initialized data does not assign door phone ringing to any station port. All LEDs are OFF.
2. A range of ports may be entered by keying in the following: *
 Low port in range — High port in range
3. Door phones will not ring Attendant Consoles or Standard Telephones. Ringing door phones will flash on idle console's answer keys, but will not alert a console that is in the busy mode.

PROGRAMMING PROCEDURES — RECORD SHEETS

SECTION 100-280-303

PROGRAM 81 ~ 89 — CO LINE/STATION AUTO ATTENDANT AND ATTENDANT CONSOLE RINGING ASSIGNMENTS

##*1*2*3 - Spkr 8 Hold - Spkr [] [] [] # [] Hold - Spkr ## Hold - Spkr ## Hold

SELECT = 1 ~ 9 for type of ringing

SELECT = Port Number(s) of station(s) that must ring

Page
or
Scroll

Buttons/LEDs = Trunks

Assigned to ring selected port number(s).
See Note 5 to select trunk ranges.

Selected trunks ring
selected station ports
per ringing program
options as follows:

DAY 8[1] Immediate
8[2] 12-second delay
8[3] 24-second delay

DAY 2 8[4] Immediate
8[5] 12-second delay
8[6] 24-second delay

NIGHT 8[7] Immediate
8[8] 12-second delay
8[9] 24-second delay

Check Off the Trunk and Port Range Covered by this Record Sheet

Trunk Range	001 ~ 040	041 ~ 080	081 ~ 120	121 ~ 144		
Port Range	000 ~ 039	040 ~ 079	080 ~ 119	120 ~ 159	160 ~ 199	200 ~ 239

Copy this page for more trunks and ports.

PORTS →																				
Trunk	LED ↓																			
	20																			
	19																			
	18																			
	17																			
	16																			
	15																			
	14																			
	13																			
	12																			
	11																			
	10																			
	09																			
	08																			
	07																			
	06																			
	05																			
	04																			
	03																			
	02																			
	01																			
	20																			
	19																			
	18																			
	17																			
	16																			
	15																			
	14																			
	13																			
	12																			
	11																			
	10																			
	09																			
	08																			
	07																			
	06																			
	05																			
	04																			
	03																			
	02																			
	01																			

NOTES:

1. Initialized data reads all LEDs ON for Port 00 in **Program 81** and port 01 in **Program 87**; all other LEDs are OFF.
2. To turn all CO LEDs on or off, after the port number is entered, press the Vol-up (all LEDs on) or Vol-down (all LEDs off). To check a particular CO line, after the port number and # is entered, press Mode and enter the CO line number, then use the # button to display and advance.
3. **Program 81 ~ 89** can be used to set-up DK280 built-in Auto Attendant delay ring feature per the guide on the next page.
4. **Program 81 ~ 89** are used to ring individual Attendant Consoles and/or to enable Attendant Console incoming CO line call load sharing. (See the next page and Section 100-280-206, Paragraph 8.20 of the DK286 I/M manual.)

PROGRAM 81 ~ 89 — CO LINE/STATION AUTO ATTENDANT AND ATTENDANT CONSOLE RINGING ASSIGNMENTS NOTES/EXAMPLE (continued)

AUTO ATTENDANT DELAY RING

NOTES:

1. To set Auto Attendant (AA) Delay ring operation follow the guidelines below.
 - A. Assign CO lines to ring the Auto Attendant (AA) in **Program 78**.
 - Program 78-61 – AA DAY**
 - 62 – AA DAY 2
 - 63 – AA NIGHT
 - B. Assign stations that should ring (immediately for 12 seconds) before the AA answers to the AA CO lines in **Program 81** (84 – Day 2, 87 – Night).
 - C. Assign stations that should ring (after a 12-second delay – for 12 seconds) before the AA answers to the AA CO lines in **Program 82** (85 – Day 2, 88 – Night).
 - D. Assign any station to ring the AA CO lines in **Program 83** (86 – Day 2, 89 – Night). This assignment is only a flag that notifies the software to delay ring stations assigned in **Program 82**. **Program 83** station assignments will not ring.
 1. No Delay: If AA line(s) are assigned to ring stations in **Program 81** but no stations are assigned in **Program 82** or **83**, the AA will answer the call immediately (no delay ring).
 2. 12 Second Delay: If AA line(s) are assigned to ring stations in **Programs 81** and **82** but no stations are assigned in **Program 83**, stations assigned in **Program 81** will ring immediately for 12 seconds and then the AA will answer (stations assigned in **Program 82** will not ring).
 3. 24 Second Delay: If AA CO line(s) are assigned to ring stations in **Programs 81, 82, and 83**, then the following ringing occurs:
 - A. Stations assigned in **Program 81** – ring immediate for 12 seconds and then stop ringing unless they are also assigned to ring in **Program 82**.
 - B. Station assigned in **Program 82** – ring after a 12-second delay for 12 seconds and then stop ringing.
 - C. The Auto Attendant Answers after stations assigned in **Program 81** and **82** stop ringing (24 seconds from start of call).
 - D. The station assigned in **Program 83** will not ring.
2. Auto Attendant Program Example:
 - A. CO lines 1 ~ 5 should ring station 200 immediately for 24 seconds (6 rings)
 - B. CO lines 1 ~ 5 should delay ring station 208 after ringing station 200 for 12 seconds.
 - C. The Auto Attendant should answer CO 1 ~ 5, 24 seconds after station 200 started ringing (12 seconds after station 208 started ringing).
Program as follows for th above example.
 1. Assign lines 001 ~ 005 to AA in **Program 78-61**.
 2. Assign lines 001 ~ 005 to ring station 200 in **Program 81** and **82**.
 3. Assign lines 001 ~ 005 to ring station 208 in **Program 82**.
 4. Assign lines 001 ~ 005 to ring any port in **Program 83** (**Program 83** assignment is used only to enable **Program 82** delay ring stations to ring).

ATTENDANT CONSOLE LOAD SHARING

1. Assign all CO lines (Ground, Loop, and DID) that should alternately ring multiple Attendant Consoles to the respective Load Share Console ports in **Programs 81, 84, and 87** (see example in Section 100-280-206, Paragraph 8.20 of the DK280 I/M manual).
2. On DID, lines, when the digits assigned to console ports in **Program *09** are dialed on incoming calls, the calls will alternately ring the Load Share Consoles.

System Record Sheets for **Programs 90, 91, and 92** are in the beginning of this section because they must be executed before any other programs.

PROGRAM 97 — PRINTING PROGRAM DATA THROUGH SMDR

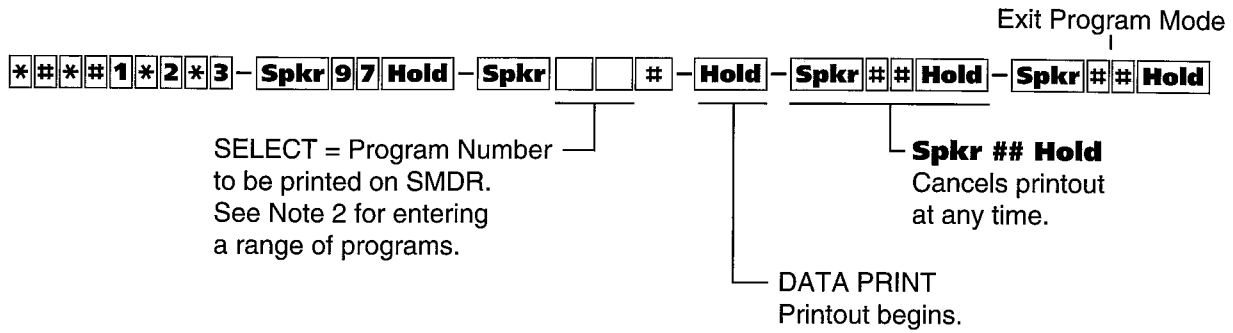

NOTES:

1. For more information, see the instructions preceding the record sheets.
2. Enter a range of programs by keying:

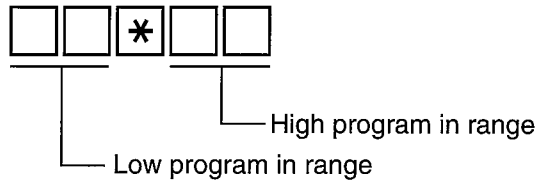

PROGRAMMING PROCEDURES

TOLL RESTRICTION SYSTEM RECORD SECTION PROGRAMS 44-1 ~ 8 THROUGH 48

PROGRAM 44-1 ~ 8 — TOLL RESTRICTION CLASS (1 ~ 8) TRAVELING CLASS OVERRIDE

###1*2*3 - Spkr 44 Hold Spkr - - - Hold - Spkr ## Hold - Spkr ## Hold

SELECT = Toll Restriction Class 1 ~ 8

DATA = 4-digit Toll Restriction Code for Selected Class

Code for Toll Restriction Class	<input type="text" value="1"/>	<input type="text"/>	<input type="text"/>	<input type="text"/>	<input type="text"/>
Code for Toll Restriction Class	<input type="text" value="2"/>	<input type="text"/>	<input type="text"/>	<input type="text"/>	<input type="text"/>
Code for Toll Restriction Class	<input type="text" value="3"/>	<input type="text"/>	<input type="text"/>	<input type="text"/>	<input type="text"/>
Code for Toll Restriction Class	<input type="text" value="4"/>	<input type="text"/>	<input type="text"/>	<input type="text"/>	<input type="text"/>
Code for Toll Restriction Class	<input type="text" value="5"/>	<input type="text"/>	<input type="text"/>	<input type="text"/>	<input type="text"/>
Code for Toll Restriction Class	<input type="text" value="6"/>	<input type="text"/>	<input type="text"/>	<input type="text"/>	<input type="text"/>
Code for Toll Restriction Class	<input type="text" value="7"/>	<input type="text"/>	<input type="text"/>	<input type="text"/>	<input type="text"/>
Code for Toll Restriction Class	<input type="text" value="8"/>	<input type="text"/>	<input type="text"/>	<input type="text"/>	<input type="text"/>

SELECT =

DATA = 4-Digit Code

NOTES:

1. For more information, see the instructions preceding the record sheets.
2. Classes 1 ~ 8 are defined in **Program 46**.
3. When the Toll Restriction Override code is dialed, the station's class defined in **Program 48** will change to the class assigned to the code in **Program 44-1 ~ 8**.
4. Do not use same codes set in **Program 45** (8 and 9).
5. Stations enabled in **Program 30**, Button/LED 16 ON, are allowed to enter and change Toll Restriction Class (1 ~ 8) override codes.
6. RCTUA and RCTUB can support up to four Toll Restriction Traveling Class codes. RCTUC/D can support up to eight.
7. Initialized Data = all Classes Blank (no code).

PROGRAM 45-1 — LCR/TOLL RESTRICTION DIAL PLAN

##1*2*3 - Spkr 4 5 Hold - Spkr 1 Hold - Spkr ## Hold - Spkr ## Hold

SELECT = 1

DATA = Plan 1 ~ 5
Enter Codes 1 ~ 5 to indicate the dial plan for the system.

X	Plan	Toll Restriction/LCR Dial Plans
	5	0+ (Note 6)
	4	Universal (Note 6)
X	3	1+AC+NXX/NNX
	2	1+AC+NXX/1+NNX
	1	AC+NXX/1+NNX

IMPORTANT: The correct Dial Plan must be assigned to allow system LCR and/or Toll Restriction to function properly.

NOTES:

1. Initialized data assigns Dial Plan Code 1 to the system.
2. In NXX and NNX, X = 0 ~ 9, N = 2 ~ 9.
3. NXX = Office code (interchangeable; second digit can be 1 or 0).
4. NNX = Office code (**not** interchangeable; second digit **cannot** be 1 or 0).
5. AC = Area Code
6. 0+, and universal (Codes 5 and 4) are not used in USA.
7. 1+ NNX indicates 1 may be dialed before office codes.

PROGRAM 45-2 — TOLL RESTRICTION DISABLE (CO LINES 001 ~ 080)

##*#1*2*3 - Spkr 4 5 Hold - Spkr 2 -  Hold - Spkr ## Hold - Spkr ## Hold

SELECT = 2

Press: **Scroll** to advance or **Page** to go back³

LEDs/Buttons

Specify CO lines by setting buttons/LEDs as defined by the table below. All LEDs with an "X" should be lit when finished.

ON = Disable Toll Restriction.

LED	Trunk	X
20	040	
19	039	
18	038	
17	037	
16	036	
15	035	
14	034	
13	033	
12	032	
11	031	
10	030	
09	029	
08	028	
07	027	
06	026	
05	025	
04	024	
03	023	
02	022	
01	021	
20	020	
19	019	
18	018	
17	017	
16	016	
15	015	
14	014	
13	013	
12	012	
11	011	
10	010	
09	009	
08	008	
07	007	
06	006	
05	005	
04	004	
03	003	
02	002	
01	001	

LED	Trunk	X
20	080	
19	079	
18	078	
17	077	
16	076	
15	075	
14	074	
13	073	
12	072	
11	071	
10	070	
09	069	
08	068	
07	067	
06	066	
05	065	
04	064	
03	063	
02	062	
01	061	
20	060	
19	059	
18	058	
17	057	
16	056	
15	055	
14	054	
13	053	
12	052	
11	051	
10	050	
09	049	
08	048	
07	047	
06	046	
05	045	
04	044	
03	043	
02	042	
01	041	

NOTES:

1. To advance the CO line range, press the **Scroll** button beneath the LCD. Press the **Page** button for a lower range.
2. Initialized data reads all LEDs OFF for all CO lines.
3. To turn all CO LEDs on or off, after the port number is entered, press the Vol-up (all LEDs on) or Vol-down (all LEDs off). To check a particular CO line, after the port number is entered, press **Mode** and enter the CO line number, then use the  button to display and advance.

PROGRAM 45-3 ~ 6 — SPECIAL COMMON CARRIER (SPCC) NUMBERS AND AUTHORIZATION CODE DIGIT LENGTH

###1*2*3 - Spkr 4 5 Hold - Spkr [] - [] [] [] [] - Hold - Spkr ## Hold - Spkr ## Hold

SELECT = Item 3 ~ 6
Enter Item number
3 ~ 6 from table below.

DATA =
First five digits of the
SPCC Number, or digit
length specified in the
table below. See Note 3.

Item	Description	1st five digits of SPCC Data = Number or Digit Length
3	SPCC1 Number	[] [] [] [] []
4	Authorization Code 1 Digit Length (00 ~ 99)	[] []
5	SPCC2	[] [] [] [] []
6	Authorization Code 2 Digit Length (00 ~ 99)	[] []

NOTES:

- For more information, see the instructions preceding the record sheets.
- Initialized data assigns "00" data to Items 4 and 6, and assigns blank data to Items 3 and 5.
- When editing,
 - Press # to move cursor.
 - Press button/LED 01 to delete or leave a blank.
 - Press button/LED 02 to allow all digits to work.
- Do not enter a digit length greater than necessary or users may be able to override Toll Restriction.
- This program is designed for the following special Common Carrier access dialing sequence: SPCC Number + Authorization Code + Telephone Number. This program requires only the first five digits of the SPCC Number (950XXXX). SMDR will print out the following: SPCC Number + ---- + Telephone Number. (The Authorization Code will not print out, and four dashes will be in its place.) Toll Restriction will start on the first digit of the Telephone Number.
- It is not necessary to assign 10XXX or 101XXXX Carrier Access Codes (CACs) in this Program. The DK280 automatically treats CACs as special codes and applies Toll Restriction and LCR appropriately.

PROGRAMMING PROCEDURES — RECORD SHEETS

SECTION 100-280-303

PROGRAM 45-8, 9 — TOLL RESTRICTION OVERRIDE CODE

##1*2*3 - Spkr 45 Hold - Spkr - - Hold - Spkr ## Hold - Spkr ## Hold

SELECT = 8 or 9
 Enter 8 to Select Code 1.
 Enter 9 to Select Code 2.

DATA = Code
 Enter the 4-digit code
 from the table below.

Select =		Code (4 digits)
8	Code 1	<input type="text"/> <input type="text"/> <input type="text"/> <input type="text"/>
9	Code 2	<input type="text"/> <input type="text"/> <input type="text"/> <input type="text"/>

NOTES:

1. For more information, see the instructions preceding the record sheets.
2. When editing the data field, use Button/LED 01 to delete a digit; Button/LED 02 to allow all digits to work.
3. Initialized data leaves code assignments blank.
4. Codes may be revised by station users specified in **Program 30**, Button/LED 09.
5. Do not use same 4-digit codes set in **Program 44B**, Toll Restriction/Traveling Class (1 ~ 8) Override codes. **Program 45** (8 ~ 9) overrides **Program 44B** (1 ~ 8) if same codes are used.

PROGRAMMING PROCEDURES — RECORD SHEETS

PROGRAM 46-2 ~ 4 — TOLL RESTRICTION ALLOWED/DENIED AREA CODES ASSIGNED BY CLASS (CLASS 1 ~ 4)

##1*2*3 - Spkr 4 6 Hold - Spkr # # # - Hold - Spkr # # # Hold - Spkr # # # Hold

SELECT = Class Number
 Enter Toll Restriction class number 1 ~ 4.

2, 3 or 4
 Enter one of the following numbers: 2 = add to memory, 3 = delete from memory, 4# = display allowed codes in memory.

DATA = Area Codes
 Enter or display area codes.
 See Notes 3 and 4.

Class	1	Allowed <input type="checkbox"/>	Denied <input type="checkbox"/>	(Check one)
Area Codes				

Class	2	Allowed <input type="checkbox"/>	Denied <input type="checkbox"/>	(Check one)
Area Codes				

Class	3	Allowed <input type="checkbox"/>	Denied <input type="checkbox"/>	(Check one)
Area Codes				

Class	4	Allowed <input type="checkbox"/>	Denied <input type="checkbox"/>	(Check one)
Area Codes				

NOTES:

1. For more information, see the instructions preceding the record sheets.
2. Initialized data includes all area codes in all classes.
3. A range of area codes can be entered by pressing:
4. Several ranges or individual area codes may be entered by separating them with the # button.
5. Tables with deny box checked do not represent memory. All area codes in memory are allowed.

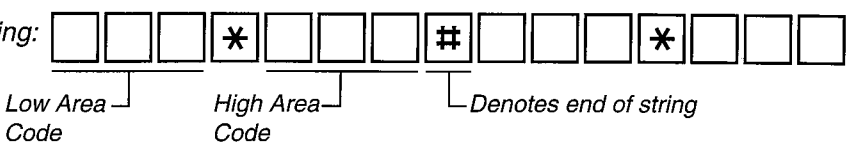

PROGRAMMING PROCEDURES — RECORD SHEETS

SECTION 100-280-303

PROGRAM 46-2 ~ 4 — TOLL RESTRICTION ALLOWED/DENIED AREA CODES ASSIGNED BY CLASS (CLASS 5 ~ 8 RCTU C/D ONLY)

##1*2*3 - Spkr 4 6 Hold - Spkr # - - Hold - Spkr ## Hold - Spkr ## Hold

SELECT = Class Number
Enter Toll Restriction
class number 5 ~ 8.

2, 3 or 4
Enter one of the following
numbers: 2 = add to memory,
3 = delete from memory,
4# = display allowed codes
in memory.

DATA = Area Codes
Enter or display
area codes.
See Notes 3 and 4.

Class	5	Allowed <input type="checkbox"/>	Denied <input type="checkbox"/>	(Check one)
Area Codes				

Class	6	Allowed <input type="checkbox"/>	Denied <input type="checkbox"/>	(Check one)
Area Codes				

Class	7	Allowed <input type="checkbox"/>	Denied <input type="checkbox"/>	(Check one)
Area Codes				

Class	8	Allowed <input type="checkbox"/>	Denied <input type="checkbox"/>	(Check one)
Area Codes				

NOTES:

1. For more information, see the instructions preceding the record sheets.
2. Initialized data includes all area codes in all classes.
3. A range of area codes can be entered by pressing:
4. Several ranges or individual area codes may be entered by separating them with the # button.
5. Tables with deny box checked do not represent memory. All area codes in memory are allowed.

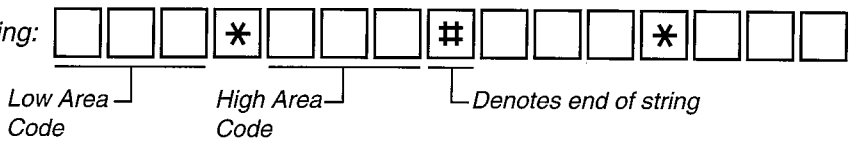

PROGRAMMING PROCEDURES — RECORD SHEETS

SECTION 100-280-303

PROGRAM 46-6~8 — TOLL RESTRICTION ALLOWED/DENIED OFFICE CODES ASSIGNED BY CLASS (CLASS 5 ~ 8 RCTU C/D ONLY)

###1*2*3 - Spkr 4 6 Hold - Spkr - - Hold - Spkr ## Hold - Spkr ## Hold

SELECT = Class Number
Enter Toll Restriction
Class 5 ~ 8.

6, 7 or 8
Enter one of the following
numbers: 6 = add to memory,
7 = delete from memory,
8# = display allowed codes
in memory.

DATA = Office Codes
Enter or display
office codes.
See Notes 3 and 4.

Class	<input type="text" value="5"/>	Allowed	<input type="checkbox"/>	Denied	<input type="checkbox"/>	(Check one)
Office Codes						

Class	<input type="text" value="6"/>	Allowed	<input type="checkbox"/>	Denied	<input type="checkbox"/>	(Check one)
Office Codes						

Class	<input type="text" value="7"/>	Allowed	<input type="checkbox"/>	Denied	<input type="checkbox"/>	(Check one)
Office Codes						

Class	<input type="text" value="8"/>	Allowed	<input type="checkbox"/>	Denied	<input type="checkbox"/>	(Check one)
Office Codes						

- NOTES:
1. Initialized data includes all area codes in all classes.
 2. A range of area codes can be entered by pressing:
 3. Several ranges or individual area codes may be entered by separating them with the button.
 4. Tables with deny box checked do not represent memory. All area codes in memory are allowed.

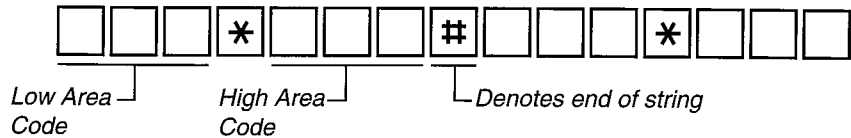

PROGRAM 46 (10~80) — TOLL RESTRICTION CLASS PARAMETERS

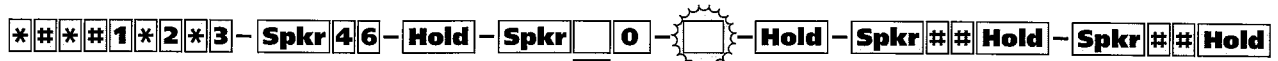

Select Class 1 ~ 8

Turn on key 01, 02, or 03 to select restriction option

Class Number	Restriction Options					
	Key 01		Key 02		Key 03	
	ON	OFF	ON	OFF	ON	OFF
	Dial 0 Restricted	Dial 0 Allowed	Dial 01 Restricted	Dial 01 Allowed	A/C + 555 OR 1 + A/C + 555 Allowed for All A/Cs	555 Allowed or Denied per A/C Restriction Table
1						
2						
3						
4						
5						
6						
7						
8						

1. Initialized Data = all LEDs off

2. RCTUA and RCTUB provides Classes 1 ~ 4, RCTU C/D provides Classes 1 ~ 8.

PROGRAMMING PROCEDURES — RECORD SHEETS

SECTION 100-280-303

PROGRAM 46 (11~81) — TOLL RESTRICTION CLASS (1~8) PARAMETERS



SELECT CLASS (1~8)

Buttons/LEDS

Light button/LEDS as required to assign Table 01~16 to Class 1~8.

Copy as required for each Class.

LED	X	LED ON	LED OFF
20			
19			
18			
17			
16		Table 16 Area/Office Exception	Not Selected
15		Table 15 Area/Office Exception	Not Selected
14		Table 14 Area/Office Exception	Not Selected
13		Table 13 Area/Office Exception	Not Selected
12		Table 12 Area/Office Exception	Not Selected
11		Table 11 Area/Office Exception	Not Selected
10		Table 10 Area/Office Exception	Not Selected
09		Table 09 Area/Office Exception	Not Selected
08		Table 08 Area/Office Exception	Not Selected
07		Table 07 Area/Office Exception	Not Selected
06		Table 06 Area/Office Exception	Not Selected
05		Table 05 Area/Office Exception	Not Selected
04		Table 04 Area/Office Exception	Not Selected
03		Table 03 Area/Office Exception	Not Selected
02		Table 02 Area/Office Exception	Not Selected
01		Table 01 Area/Office Exception	Not Selected

NOTES:

1. For more information, see the instructions preceding the record sheets.
2. Initialized data leaves all LEDs OFF.
3. RCTUA and RCTUB provide 8 tables, RCTU C/D provides 16 tables.
4. RCTUA and RCTUB provides Classes 1 ~ 4, RCTU C/D provides Classes 1 ~ 8.
5. Table 01 ~ 16, Area/Office Exception tables are created with **Program 47**.

PROGRAMMING PROCEDURES — RECORD SHEETS

PROGRAM 48 — STATION TOLL RESTRICTION CLASSIFICATION (PORTS 000 ~ 120)

###1*2*3 - Spkr 4 8 Hold - Spkr [] [] [] # - [] [] [] - Hold - Spkr ## Hold - Spkr ## Hold

SELECT = Port Number(s)
 Enter the port number(s) of the station(s) being defined.
 See Note 3 for entering a range.

DATA =
 Digit Restriction Code 0 or 1
 Enter 0 for no digit restriction.
 Enter 1 for digit restriction.

Station Restriction Code (00 ~ 10)
 Enter 00 for No Station Toll Restriction.
 Enter 01 for Area Code Toll Restriction.
 Enter 02 for Area Code Toll Restriction and 0 or 1 as 1st or 2nd digit.
 Enter 03 for Class 1 T.R. Enter 07 for Class 5
 Enter 04 for Class 2 T.R. Enter 08 for Class 6
 Enter 05 for Class 3 T.R. Enter 09 for Class 7
 Enter 06 for Class 4 T.R. Enter 10 for Class 8

Port No.	Digit Restrict Code	Station Restrict Code
000		
001		
002		
003		
004		
005		
006		
007		
008		
009		
010		
011		
012		
013		
014		
015		
016		
017		
018		
019		
020		
021		
022		
023		
024		
025		
026		
027		
028		
029		
030		
031		

Port No.	Digit Restrict Code	Station Restrict Code
032		
033		
034		
035		
036		
037		
038		
039 ³		
040		
041		
042		
043		
044		
045		
046		
047		
048		
049		
050		
051		
052		
053		
054		
055		
056		
057		
058		
059		
060		
061		
062		
063		

Port No.	Digit Restrict Code	Station Restrict Code
064		
065		
066		
067		
068		
069		
070		
071		
072		
073		
074		
075		
076		
077		
078		
079		
080		
081		
082		
083		
084		
085		
086		
087		
088		
089 ³		
090		
091		
092		
093		
094		
095		

Port No.	Digit Restrict Code	Station Restrict Code
096		
097		
098		
099		
100		
101		
102		
103		
104		
105		
106		
107		
108		
109		
110		
111		
112		
113		
114		
115		
116		
117		
118		
119		
120		

NOTES:

1. Initialized data reads "100" for all ports.
2. Toll Restriction Classification Ports for DISA calls are: Port 039-RCTUA, Port 089-RCTUB, and Port 249 for RCTU C/D.
3. A range of ports may be entered:

[] [] [] * [] [] []

Low port in range

High port in range

4. RCTU C/D provides 8 classes, RCTUA and RCTUB provides 4 classes.

PROGRAM 48 — STATION TOLL RESTRICTION CLASSIFICATION (PORTS 121 ~ 239)

##1*2*3 - Spkr 4 8 Hold - Spkr [] [] [] # - [] [] [] - Hold - Spkr ## Hold - Spkr ## Hold

SELECT = Port Number(s) _____
 Enter the port number(s) of the station(s) being defined.
 See Note 3 for entering a range.

DATA = _____
 Digit Restriction Code 0 or 1
 Enter 0 for no digit restriction.
 Enter 1 for digit restriction.

Station Restriction Code (00 ~ 10)
 Enter 00 for No Station Toll Restriction.
 Enter 01 for Area Code Toll Restriction.
 Enter 02 for Area Code Toll Restriction and 0 or 1 as 1st or 2nd digit.
 Enter 03 for Class 1 T.R. Enter 07 for Class 5
 Enter 04 for Class 2 T.R. Enter 08 for Class 6
 Enter 05 for Class 3 T.R. Enter 09 for Class 7
 Enter 06 for Class 4 T.R. Enter 10 for Class 8

Port No.	Digit Restrict Code	Station Restrict Code
121		
122		
123		
124		
125		
126		
127		
128		
129		
130		
131		
132		
133		
134		
135		
136		
137		
138		
139		
140		
141		
142		
143		
144		
145		
146		
147		
148		
149		
150		
151		
152		

Port No.	Digit Restrict Code	Station Restrict Code
153		
154		
155		
156		
157		
158		
159		
160		
161		
162		
163		
164		
165		
166		
167		
168		
169		
170		
171		
172		
173		
174		
175		
176		
177		
178		
179		
180		
181		
182		
183		
184		

Port No.	Digit Restrict Code	Station Restrict Code
185		
186		
187		
188		
189		
190		
191		
192		
193		
194		
195		
196		
197		
198		
199		
200		
201		
202		
203		
204		
205		
206		
207		
208		
209		
210		
211		
212		
213		
214		
215		
216		

Port No.	Digit Restrict Code	Station Restrict Code
217		
218		
219		
220		
221		
222		
223		
224		
225		
226		
227		
228		
229		
230		
231		
232		
233		
234		
235		
236		
237		
238		
239		
249		DISA ³

NOTES:

1. Initialized data reads "100" for all ports.
2. Toll Restriction Classification Ports for DISA calls are: Port 039-RCTUA, Port 089-RCTUB, and Port 249 for RCTU C/D.
3. A range of ports may be entered: [] [] [] * [] [] []

Low port in range — High port in range

4. RCTU C/D provides 8 classes, RCTUA and RCTUB provides 4 classes.

PROGRAMMING PROCEDURES

LEAST COST ROUTING SYSTEM RECORD SECTION PROGRAMS 50 ~ 56

LCR CO LINE PROGRAMMING

- 1) Use **Program 16** to assign trunks in groups per the reference chart below.

CO line Group Reference Chart

Line Group	CO line in Group	CO line Type/Comments
801		
802		
803		
804		
805		
806		
807		
808		
809		
810		
811		
812		
813		
814		
815		
816		

- 2) Use **Program 40** to allow trunk access to stations using LCR for outgoing calls.
- 3) Use **Program 41** to deny outgoing trunk access, except for LCR access.
*Important: Area code and office code structure must be defined by **Program 45-1** (Toll Restriction Dial Plan) for LCR to work properly.*
- 4) Use **Program 45-1** to enable the dial plan that is appropriate for the area where LCR calls will originate.

PROGRAM 50-1 — LCR PARAMETERS

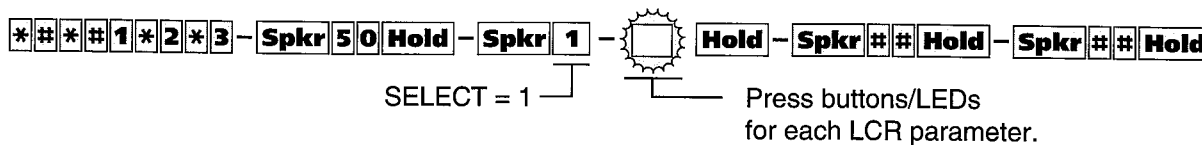

LED	X	LED ON	LED OFF
1	X	Enable System LCR	No LCR
2		Not Used	Not Used
3	X	555 LDI Route Per Program 50-4	Per Area Code Table
4	X	Dial Tone After LCR Access	Silent
5		Warning Tone Last Choice Route No.	No Warning Tone

NOTES:

1. For more information, see the instructions preceding the record sheets.
2. **Program 40** denies CO line access via LCR and denies all other access methods.
3. **Program 41** allows CO line access via LCR, but denies all other outgoing access methods: (#7001 ~ #7144, 801 ~ 816, Line button).
4. Initialized data: All LEDs OFF.
5. Toll Restricted standard telephones should be forced to dial outgoing calls via LCR. This is to prevent Toll Restriction defeat when the RRCS times out.

PROGRAM 50-2 — LCR HOME AREA CODE

##1*2*3 - Spkr 5 0 Hold - Spkr 2 [] [] [] Hold - Spkr ## Hold - Spkr ## Hold

SELECT = 2

DATA = Home Area Code
Enter the local area code.

LCR Home Area Code

8 0 0

NOTES:

1. For more information, see the instructions preceding the record sheets.
2. Typically this code is entered in **Program 51** table for the LCR route plan number defined for the local calls in **Program 50-5**.
3. Initialized data leaves the home area code blank.

PROGRAM 50-31 ~ 35 — LCR SPECIAL CODES

##1*2*3 - Spkr 5 0 Hold - Spkr [] [] - [] [] [] [] Hold - Spkr ## Hold - Spkr ## Hold

SELECT = 31 ~ 35
Enter 31 ~ 35 to indicate the special code.

DATA = Special Code
Enter the code from the table below.

	Special Code	Examples
31	9 1	1-411
32	4 1 1	911
33		611
34		
35		

NOTES:

1. For more information, see the instructions preceding the record sheets.
2. Initialized data leaves all codes blank.
3. Press Button/LED 01 to erase data; and leave blank.
4. These calls follow the local call route defined in **Program 50-5**.

PROGRAM 50-4 — LCR LONG DISTANCE INFORMATION (LDI) PLAN NUMBER

##1*2*3 - Spkr 5 0 Hold - Spkr 4 [] [] Hold - Spkr ## Hold - Spkr ## Hold

SELECT = 4

DATA = LDI Route Plan (01 ~ 16)⁴
Identify the LDI Route Plan
by entering 01 ~ 16.

NOTES:

1. For more information, see the instructions preceding the record sheets.
2. Initialized data assigns LDI Plan Number 16 for RCTU C/D, or Number 8 for RCTUA and B.
3. Typically, LDI Plan Number = Local Call Plan Number.
4. RCTUA and B provide 8 LCR Route Plans, RCTU C/D provides 16.

PROGRAM 50-5 — LCR LOCAL CALL PLAN NUMBER

##1*2*3 - Spkr 5 0 Hold - Spkr 5 [] [] Hold - Spkr ## Hold - Spkr ## Hold

SELECT = 5

DATA = Local Route Plan (01 ~ 16)⁴
Identify the Local Route Plan
by entering 01 ~ 16.

NOTES:

1. For more information, see the instructions preceding the record sheets.
2. Initialized data assigns Plan 16 to be the local call plan for RCTU C/D, or Plan 8 for RCTUA and B.
3. The local plan handles special codes and operator calls.
4. RCTUA and B provide 8 LCR Route Plans, RCTU C/D provide 16.

PROGRAM 50-6 — LCR DIAL ZERO TIME-OUT

##1*2*3 - Spkr 5 0 Hold - Spkr 6 [] [] Hold - Spkr ## Hold - Spkr ## Hold

SELECT = 6

DATA = Time-out Value
Enter a time-out value from
04 ~ 10 seconds long.

NOTES:

1. For more information, see the instructions preceding the record sheets.
2. Initialized data assigns an LCR Dial Zero Time-out value of 06.
3. This value determines pause time before sending a call on to an operator, etc.

PROGRAMMING PROCEDURES — RECORD SHEETS

SECTION 100-280-303

PROGRAM 52 — LCR OFFICE CODE EXCEPTIONS FOR SPECIFIED AREA CODE (5 ~ 8)

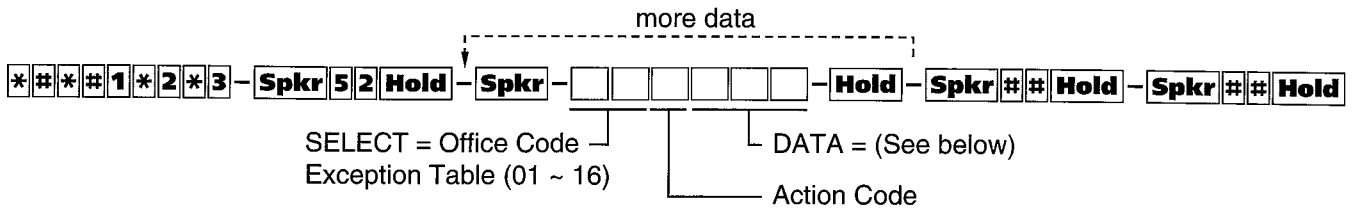

Action Code Function	Action Codes	DATA =
Assign Exception Table to LCR Plan	0	[] LCR Plan 1 ~ 16
Assign Area Code to LCR Plan	1	[] [] [] 3-digit Area Code
Add Office Codes to Exception Table	2	[] [] [] 3-digit Office Code
Delete Office Codes from Exception Table	3	[] [] [] 3-digit Office Code
Display Office Codes in Exception Table	4 # more #	[] [] [] 3-digit Office Code

Office Code Exception Table **05** for Area Code [] [] []

Assign to LCR Route Plan Number [] Office Codes:

[]	[]	[]	[]	[]	[]	[]	[]	[]	[]	[]	[]	[]	[]	[]	[]	[]	[]	[]	[]
[]	[]	[]	[]	[]	[]	[]	[]	[]	[]	[]	[]	[]	[]	[]	[]	[]	[]	[]	[]

Office Code Exception Table **06** for Area Code [] [] []

Assign to LCR Route Plan Number [] Office Codes:

[]	[]	[]	[]	[]	[]	[]	[]	[]	[]	[]	[]	[]	[]	[]	[]	[]	[]	[]	[]
[]	[]	[]	[]	[]	[]	[]	[]	[]	[]	[]	[]	[]	[]	[]	[]	[]	[]	[]	[]

Office Code Exception Table **07** for Area Code [] [] []

Assign to LCR Route Plan Number [] Office Codes:

[]	[]	[]	[]	[]	[]	[]	[]	[]	[]	[]	[]	[]	[]	[]	[]	[]	[]	[]	[]
[]	[]	[]	[]	[]	[]	[]	[]	[]	[]	[]	[]	[]	[]	[]	[]	[]	[]	[]	[]

Office Code Exception Table **08** for Area Code [] [] []

Assign to LCR Route Plan Number [] Office Codes:

[]	[]	[]	[]	[]	[]	[]	[]	[]	[]	[]	[]	[]	[]	[]	[]	[]	[]	[]	[]
[]	[]	[]	[]	[]	[]	[]	[]	[]	[]	[]	[]	[]	[]	[]	[]	[]	[]	[]	[]

NOTES:

- For more information, see the instructions preceding the record sheets.
- Initialized data leaves all codes blank.
- To enter a range of Office codes, press:



Low Office Code High Area Code Denotes end of string

- Several ranges or individual codes can be expressed at once by separating them with the # button.

PROGRAMMING PROCEDURES — RECORD SHEETS

PROGRAM 53 — LCR SCHEDULE ASSIGNMENTS FOR LCR PLAN NO. 1 AND 2

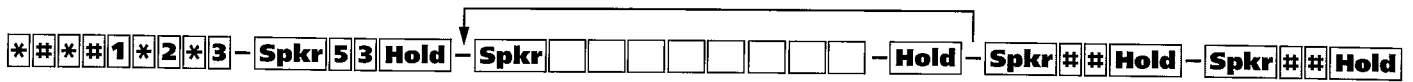

SELECT = [] Start TM or DATA

	SELECT	Start TM
Start TM	01 1 0	[] [] [] []
Schedule (1 ~ 3)	01 2 0	[] [] [] []
Plan <u>1</u>	01 3 0	[] [] [] []
LCR Plan		H H M M
Schedule (1 ~ 3)		(HH = 00 ~ 23
Action Code		MM = 00 ~ 59)

	SELECT	Start TM
Start TM	02 1 0	[] [] [] []
Schedule (1 ~ 3)	02 2 0	[] [] [] []
Plan <u>2</u>	02 3 0	[] [] [] []
LCR Plan		H H M M
Schedule (1 ~ 3)		(HH = 00 ~ 23
Action Code		MM = 00 ~ 59)

	SELECT	DATA (Route Choices)
Schedule 1 Route Choices For Plan <u>01</u>	01 1 1	[] [] [] []
	01 1 2	[] [] [] []
	01 1 3	[] [] [] []
	01 1 4	[] [] [] []
	01 1 5	[] [] [] []
	01 1 6	[] [] [] []
	01 1 7	[] [] [] []
	01 1 8	[] [] [] []
Schedule 2 Route Choices For Plan <u>01</u>	01 2 1	[] [] [] []
	01 2 2	[] [] [] []
	01 2 3	[] [] [] []
	01 2 4	[] [] [] []
	01 2 5	[] [] [] []
	01 2 6	[] [] [] []
	01 2 7	[] [] [] []
	01 2 8	[] [] [] []
Schedule 3 Route Choices For Plan <u>01</u>	01 3 1	[] [] [] []
	01 3 2	[] [] [] []
	01 3 3	[] [] [] []
	01 3 4	[] [] [] []
	01 3 5	[] [] [] []
	01 3 6	[] [] [] []
	01 3 7	[] [] [] []
	01 3 8	[] [] [] []
LCR Plan		1st 2nd 3rd Last
Schedule (1 ~ 3)		(Route Definition
LCR Station		No's (1 ~ 6) ⁶
Group No. (1 ~ 8) ⁵		From Program 54)

	SELECT	DATA (Route Choices)
Schedule 1 Route Choices For Plan <u>02</u>	02 1 1	[] [] [] []
	02 1 2	[] [] [] []
	02 1 3	[] [] [] []
	02 1 4	[] [] [] []
	02 1 5	[] [] [] []
	02 1 6	[] [] [] []
	02 1 7	[] [] [] []
	02 1 8	[] [] [] []
Schedule 2 Route Choices For Plan <u>02</u>	02 2 1	[] [] [] []
	02 2 2	[] [] [] []
	02 2 3	[] [] [] []
	02 2 4	[] [] [] []
	02 2 5	[] [] [] []
	02 2 6	[] [] [] []
	02 2 7	[] [] [] []
	02 2 8	[] [] [] []
Schedule 3 Route Choices For Plan <u>02</u>	02 3 1	[] [] [] []
	02 3 2	[] [] [] []
	02 3 3	[] [] [] []
	02 3 4	[] [] [] []
	02 3 5	[] [] [] []
	02 3 6	[] [] [] []
	02 3 7	[] [] [] []
	02 3 8	[] [] [] []
LCR Plan		1st 2nd 3rd Last
Schedule (1 ~ 3)		(Route Definition
LCR Station		No's (1 ~ 6) ⁶
Group No. (1 ~ 8) ⁵		From Program 54)

NOTES:

1. For more information, see the instructions preceding the record sheets.
2. Initialized data assigns starting time as 0000 and Route Definitions as blank for all schedules.
3. If Schedules 1 & 2 start at the same time, then Time of Day schedule change does not occur, and data only needs to be entered for Schedule 1.
4. Press Button/LED 01 to erase data (LED does not light)
5. RCTUA and RCTUB provides 4 LCR station groups, RCTU C/D provides 8 LCR station groups
6. RCTUA and RCTUB provides 4 route definition Nos., RCTU C/D provides 6 route definition Nos.

PROGRAMMING PROCEDURES — RECORD SHEETS

SECTION 100-280-303

PROGRAM 53 — LCR SCHEDULE ASSIGNMENTS FOR LCR PLAN NO. 3 AND 4



SELECT = [] Start TM or DATA

SELECT	Start TM
03 1 0	[] [] [] []
03 2 0	[] [] [] []
03 3 0	[] [] [] []

Start TM Schedule (1 ~ 3) Plan 3

LCR Plan Schedule (1 ~ 3) Action Code

H H M M
(HH = 00 ~ 23
MM = 00 ~ 59)

SELECT	Start TM
04 1 0	[] [] [] []
04 2 0	[] [] [] []
04 3 0	[] [] [] []

Start TM Schedule (1 ~ 3) Plan 4

LCR Plan Schedule (1 ~ 3) Action Code

H H M M
(HH = 00 ~ 23
MM = 00 ~ 59)

SELECT	DATA (Route Choices)
03 1 1	[] [] [] []
03 1 2	[] [] [] []
03 1 3	[] [] [] []
03 1 4	[] [] [] []
03 1 5	[] [] [] []
03 1 6	[] [] [] []
03 1 7	[] [] [] []
03 1 8	[] [] [] []
03 2 1	[] [] [] []
03 2 2	[] [] [] []
03 2 3	[] [] [] []
03 2 4	[] [] [] []
03 2 5	[] [] [] []
03 2 6	[] [] [] []
03 2 7	[] [] [] []
03 2 8	[] [] [] []
03 3 1	[] [] [] []
03 3 2	[] [] [] []
03 3 3	[] [] [] []
03 3 4	[] [] [] []
03 3 5	[] [] [] []
03 3 6	[] [] [] []
03 3 7	[] [] [] []
03 3 8	[] [] [] []

Schedule 1 Route Choices For Plan 03

Schedule 2 Route Choices For Plan 03

Schedule 3 Route Choices For Plan 03

LCR Plan Schedule (1 ~ 3) LCR Station Group No. (1 ~ 8)⁵ (see Program 56)

1st 2nd 3rd Last
(Route Definition No's (1 ~ 6)⁶ From Program 54)

SELECT	DATA (Route Choices)
04 1 1	[] [] [] []
04 1 2	[] [] [] []
04 1 3	[] [] [] []
04 1 4	[] [] [] []
04 1 5	[] [] [] []
04 1 6	[] [] [] []
04 1 7	[] [] [] []
04 1 8	[] [] [] []
04 2 1	[] [] [] []
04 2 2	[] [] [] []
04 2 3	[] [] [] []
04 2 4	[] [] [] []
04 2 5	[] [] [] []
04 2 6	[] [] [] []
04 2 7	[] [] [] []
04 2 8	[] [] [] []
04 3 1	[] [] [] []
04 3 2	[] [] [] []
04 3 3	[] [] [] []
04 3 4	[] [] [] []
04 3 5	[] [] [] []
04 3 6	[] [] [] []
04 3 7	[] [] [] []
04 3 8	[] [] [] []

Schedule 1 Route Choices For Plan 04

Schedule 2 Route Choices For Plan 04

Schedule 3 Route Choices For Plan 04

LCR Plan Schedule (1 ~ 3) LCR Station Group No. (1 ~ 8)⁵ (see Program 56)

1st 2nd 3rd Last
(Route Definition No's (1 ~ 6)⁶ From Program 54)

- NOTES:
- For more information, see the instructions preceding the record sheets.
 - Initialized data assigns starting time as 0000 and Route Definitions as blank for all schedules.
 - If Schedules 1 & 2 start at the same time, then Time of Day schedule change does not occur, and data only needs to be entered for Schedule 1.
 - Press Button/LED 01 to erase data (LED does not light)
 - RCTUA and RCTUB provides 4 LCR station groups, RCTU C/D provides 8 LCR station groups
 - RCTUA and RCTUB provides 4 route definition Nos., RCTU C/D provides 6 route definition Nos.

PROGRAM 53 — LCR SCHEDULE ASSIGNMENTS FOR LCR PLAN NO. 5 AND 6

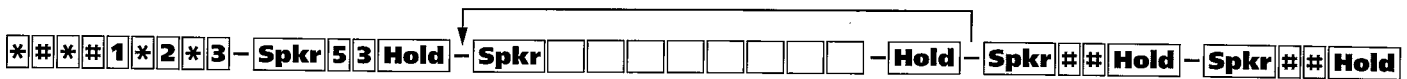

SELECT Start TM

05	1	0				
05	2	0				
05	3	0				

Start TM
Schedule (1 ~ 3)
Plan 5

LCR Plan _____
Schedule (1 ~ 3) _____
Action Code _____

H H M M
(HH = 00 ~ 23
MM = 00 ~ 59)

SELECT DATA (Route Choices)

Schedule 1
Route Choices
For Plan 05

05	1	1				
05	1	2				
05	1	3				
05	1	4				
05	1	5				
05	1	6				
05	1	7				
05	1	8				

Schedule 2
Route Choices
For Plan 05

05	2	1				
05	2	2				
05	2	3				
05	2	4				
05	2	5				
05	2	6				
05	2	7				
05	2	8				

Schedule 3
Route Choices
For Plan 05

05	3	1				
05	3	2				
05	3	3				
05	3	4				
05	3	5				
05	3	6				
05	3	7				
05	3	8				

LCR Plan _____
Schedule (1 ~ 3) _____
LCR Station _____
Group No. (1 ~ 8)⁵
(see Program 56)

1st 2nd 3rd Last
(Route Definition
No's (1 ~ 6)⁶
From Program 54)

SELECT Start TM

06	1	0				
06	2	0				
06	3	0				

Start TM
Schedule (1 ~ 3)
Plan 06

LCR Plan _____
Schedule (1 ~ 3) _____
Action Code _____

H H M M
(HH = 00 ~ 23
MM = 00 ~ 59)

SELECT DATA (Route Choices)

Schedule 1
Route Choices
For Plan 06

06	1	1				
06	1	2				
06	1	3				
06	1	4				
06	1	5				
06	1	6				
06	1	7				
06	1	8				

Schedule 2
Route Choices
For Plan 06

06	2	1				
06	2	2				
06	2	3				
06	2	4				
06	2	5				
06	2	6				
06	2	7				
06	2	8				

Schedule 3
Route Choices
For Plan 06

06	3	1				
06	3	2				
06	3	3				
06	3	4				
06	3	5				
06	3	6				
06	3	7				
06	3	8				

LCR Plan _____
Schedule (1 ~ 3) _____
LCR Station _____
Group No. (1 ~ 8)⁵
(see Program 56)

1st 2nd 3rd Last
(Route Definition
No's (1 ~ 6)⁶
From Program 54)

- NOTES:
1. For more information, see the instructions preceding the record sheets.
 2. Initialized data assigns starting time as 0000 and Route Definitions as blank for all schedules.
 3. If Schedules 1 & 2 start at the same time, then Time of Day schedule change does not occur, and data only needs to be entered for Schedule 1.
 4. Press Button/LED 01 to erase data (LED does not light)
 5. RCTUA and RCTUB provides 4 LCR station groups, RCTU C/D provides 8 LCR station groups
 6. RCTUA and RCTUB provides 4 route definition Nos., RCTU C/D provides 6 route definition Nos.

PROGRAM 53 — LCR SCHEDULE ASSIGNMENTS FOR LCR PLAN NO. 7 AND 8

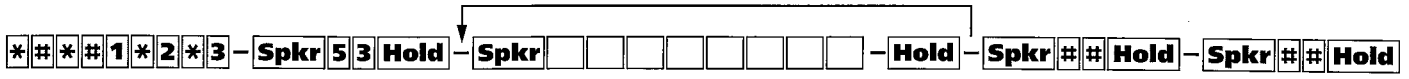

SELECT = _____ Start TM or DATA

	SELECT	Start TM
Start TM	07 1 0	
Schedule (1 ~ 3)	07 2 0	
Plan <u>7</u>	07 3 0	
LCR Plan _____		H H M M
Schedule (1 ~ 3) _____		(HH = 00 ~ 23
Action Code _____		MM = 00 ~ 59)
	SELECT	DATA (Route Choices)
Schedule 1	07 1 1	
Route Choices	07 1 2	
For Plan <u>07</u>	07 1 3	
	07 1 4	
	07 1 5	
	07 1 6	
	07 1 7	
	07 1 8	
Schedule 2	07 2 1	
Route Choices	07 2 2	
For Plan <u>07</u>	07 2 3	
	07 2 4	
	07 2 5	
	07 2 6	
	07 2 7	
	07 2 8	
Schedule 3	07 3 1	
Route Choices	07 3 2	
For Plan <u>07</u>	07 3 3	
	07 3 4	
	07 3 5	
	07 3 6	
	07 3 7	
	07 3 8	
LCR Plan _____		1st 2nd 3rd Last
Schedule (1 ~ 3) _____		(Route Definition
LCR Station _____		No's (1 ~ 6) ⁶
Group No. (1 ~ 8) ⁵		From Program 54)
(see Program 56)		

	SELECT	Start TM
Start TM	08 1 0	
Schedule (1 ~ 3)	08 2 0	
Plan <u>08</u>	08 3 0	
LCR Plan _____		H H M M
Schedule (1 ~ 3) _____		(HH = 00 ~ 23
Action Code _____		MM = 00 ~ 59)
	SELECT	DATA (Route Choices)
Schedule 1	08 1 1	
Route Choices	08 1 2	
For Plan <u>08</u>	08 1 3	
	08 1 4	
	08 1 5	
	08 1 6	
	08 1 7	
	08 1 8	
Schedule 2	08 2 1	
Route Choices	08 2 2	
For Plan <u>08</u>	08 2 3	
	08 2 4	
	08 2 5	
	08 2 6	
	08 2 7	
	08 2 8	
Schedule 3	08 3 1	
Route Choices	08 3 2	
For Plan <u>08</u>	08 3 3	
	08 3 4	
	08 3 5	
	08 3 6	
	08 3 7	
	08 3 8	
LCR Plan _____		1st 2nd 3rd Last
Schedule (1 ~ 3) _____		(Route Definition
LCR Station _____		No's (1 ~ 6) ⁶
Group No. (1 ~ 8) ⁵		From Program 54)
(see Program 56)		

NOTES:

1. For more information, see the instructions preceding the record sheets.
2. Initialized data assigns starting time as 0000 and Route Definitions as blank for all schedules.
3. If Schedules 1 & 2 start at the same time, then Time of Day schedule change does not occur, and data only needs to be entered for Schedule 1.
4. Press Button/LED 01 to erase data (LED does not light).
5. RCTUA and RCTUB provides 4 LCR station groups, RCTU C/D provides 8 LCR station groups
6. RCTUA and RCTUB provides 4 route definition Nos., RCTU C/D provides 6 route definition Nos.

PROGRAM 53 — LCR SCHEDULE ASSIGNMENTS FOR LCR PLAN NO. 9 AND 10
(RCTU C/D ONLY)

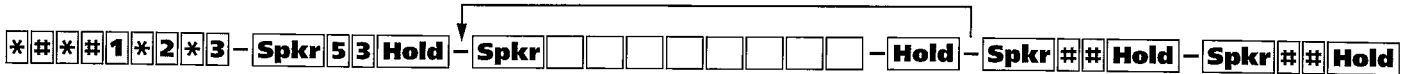

SELECT = _____ Start TM or DATA

SELECT **Start TM**

Start TM Schedule (1 ~ 3) Plan <u> 9 </u>	09 1 0 09 2 0 09 3 0				
LCR Plan _____ Schedule (1 ~ 3) _____ Action Code _____		H	H	M	M

(HH = 00 ~ 23
MM = 00 ~ 59)

SELECT **Start TM**

Start TM Schedule (1 ~ 3) Plan <u> 10 </u>	10 1 0 10 2 0 10 3 0				
LCR Plan _____ Schedule (1 ~ 3) _____ Action Code _____		H	H	M	M

(HH = 00 ~ 23
MM = 00 ~ 59)

SELECT **DATA (Route Choices)**

Schedule 1 Route Choices For Plan <u> 09 </u>	09 1 1				
	09 1 2				
	09 1 3				
	09 1 4				
	09 1 5				
	09 1 6				
	09 1 7				
	09 1 8				
Schedule 2 Route Choices For Plan <u> 09 </u>	09 2 1				
	09 2 2				
	09 2 3				
	09 2 4				
	09 2 5				
	09 2 6				
	09 2 7				
	09 2 8				
Schedule 3 Route Choices For Plan <u> 09 </u>	09 3 1				
	09 3 2				
	09 3 3				
	09 3 4				
	09 3 5				
	09 3 6				
	09 3 7				
	09 3 8				

LCR Plan _____
Schedule (1 ~ 3) _____
LCR Station _____
Group No. (1 ~ 8)⁵
(see Program 56)

1st 2nd 3rd Last
(Route Definition
No's (1 ~ 6)⁶
From Program 54)

SELECT **DATA (Route Choices)**

Schedule 1 Route Choices For Plan <u> 10 </u>	10 1 1				
	10 1 2				
	10 1 3				
	10 1 4				
	10 1 5				
	10 1 6				
	10 1 7				
	10 1 8				
Schedule 2 Route Choices For Plan <u> 10 </u>	10 2 1				
	10 2 2				
	10 2 3				
	10 2 4				
	10 2 5				
	10 2 6				
	10 2 7				
	10 2 8				
Schedule 3 Route Choices For Plan <u> 10 </u>	10 3 1				
	10 3 2				
	10 3 3				
	10 3 4				
	10 3 5				
	10 3 6				
	10 3 7				
	10 3 8				

LCR Plan _____
Schedule (1 ~ 3) _____
LCR Station _____
Group No. (1 ~ 8)⁵
(see Program 56)

1st 2nd 3rd Last
(Route Definition
No's (1 ~ 6)⁶
From Program 54)

NOTES:

1. For more information, see the instructions preceding the record sheets.
2. Initialized data assigns starting time as 0000 and Route Definitions as blank for all schedules.
3. If Schedules 1 & 2 start at the same time, then Time of Day schedule change does not occur, and data only needs to be entered for Schedule 1.
4. Press Button/LED 01 to erase data (LED does not light)
5. RCTUA and RCTUB provides 4 LCR station groups, RCTU C/D provides 8 LCR station groups
6. RCTUA and RCTUB provides 4 route definition Nos., RCTU C/D provides 6 route definition Nos.

PROGRAM 53 — LCR SCHEDULE ASSIGNMENTS FOR LCR PLAN NO. 13 AND 14
(RCTU C/D ONLY)

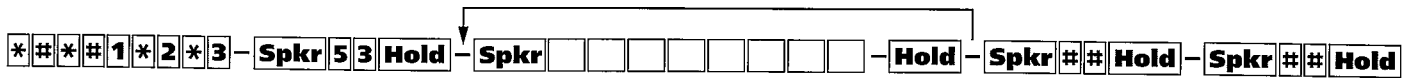

SELECT = _____ Start TM or DATA

SELECT	Start TM
13 1 0	
13 2 0	
13 3 0	

Start TM Schedule (1 ~ 3)
Plan 13

LCR Plan _____
Schedule (1 ~ 3)
Action Code _____

H H M M
(HH = 00 ~ 23
MM = 00 ~ 59)

SELECT	Start TM
14 1 0	
14 2 0	
14 3 0	

Start TM Schedule (1 ~ 3)
Plan 14

LCR Plan _____
Schedule (1 ~ 3)
Action Code _____

H H M M
(HH = 00 ~ 23
MM = 00 ~ 59)

SELECT	DATA (Route Choices)
13 1 1	
13 1 2	
13 1 3	
13 1 4	
13 1 5	
13 1 6	
13 1 7	
13 1 8	
13 2 1	
13 2 2	
13 2 3	
13 2 4	
13 2 5	
13 2 6	
13 2 7	
13 2 8	
13 3 1	
13 3 2	
13 3 3	
13 3 4	
13 3 5	
13 3 6	
13 3 7	
13 3 8	

Schedule 1
Route Choices
For Plan 13

Schedule 2
Route Choices
For Plan 13

Schedule 3
Route Choices
For Plan 13

LCR Plan _____
Schedule (1 ~ 3)
LCR Station _____
Group No. (1 ~ 8)⁵
(see Program 56)

1st 2nd 3rd Last
(Route Definition
No's (1 ~ 6)⁶
From Program 54)

SELECT	DATA (Route Choices)
14 1 1	
14 1 2	
14 1 3	
14 1 4	
14 1 5	
14 1 6	
14 1 7	
14 1 8	
14 2 1	
14 2 2	
14 2 3	
14 2 4	
14 2 5	
14 2 6	
14 2 7	
14 2 8	
14 3 1	
14 3 2	
14 3 3	
14 3 4	
14 3 5	
14 3 6	
14 3 7	
14 3 8	

Schedule 1
Route Choices
For Plan 14

Schedule 2
Route Choices
For Plan 14

Schedule 3
Route Choices
For Plan 14

LCR Plan _____
Schedule (1 ~ 3)
LCR Station _____
Group No. (1 ~ 8)⁵
(see Program 56)

1st 2nd 3rd Last
(Route Definition
No's (1 ~ 6)⁶
From Program 54)

NOTES:

1. For more information, see the instructions preceding the record sheets.
2. Initialized data assigns starting time as 0000 and Route Definitions as blank for all schedules.
3. If Schedules 1 & 2 start at the same time, then Time of Day schedule change does not occur, and data only needs to be entered for Schedule 1.
4. Press Button/LED 01 to erase data (LED does not light)
5. RCTUA and RCTUB provides 4 LCR station groups, RCTU C/D provides 8 LCR station groups
6. RCTUA and RCTUB provides 4 route definition Nos., RCTU C/D provides 6 route definition Nos.

PROGRAM 53 — LCR SCHEDULE ASSIGNMENTS FOR LCR PLAN NO. 15 AND 16 (RCTU C/D ONLY)

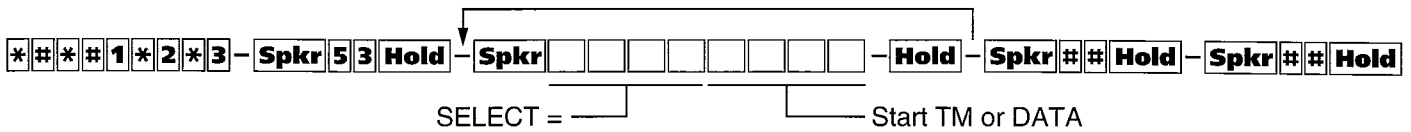

SELECT	Start TM						
Start TM Schedule (1 ~ 3) Plan <u>15</u>	15	1	0				
	15	2	0				
	15	3	0				
LCR Plan Schedule (1 ~ 3) Action Code				H	H	M	M

(HH = 00 ~ 23
MM = 00 ~ 59)

SELECT	Start TM						
Start TM Schedule (1 ~ 3) Plan <u>16</u>	16	1	0				
	16	2	0				
	16	3	0				
LCR Plan Schedule (1 ~ 3) Action Code				H	H	M	M

(HH = 00 ~ 23
MM = 00 ~ 59)

SELECT	DATA (Route Choices)						
Schedule 1 Route Choices For Plan <u>15</u>	15	1	1				
	15	1	2				
	15	1	3				
	15	1	4				
	15	1	5				
	15	1	6				
	15	1	7				
	15	1	8				
Schedule 2 Route Choices For Plan <u>15</u>	15	2	1				
	15	2	2				
	15	2	3				
	15	2	4				
	15	2	5				
	15	2	6				
	15	2	7				
	15	2	8				
Schedule 3 Route Choices For Plan <u>15</u>	15	3	1				
	15	3	2				
	15	3	3				
	15	3	4				
	15	3	5				
	15	3	6				
	15	3	7				
	15	3	8				

LCR Plan Schedule (1 ~ 3) LCR Station Group No. (1 ~ 8)⁵ (see Program 56)

1st 2nd 3rd Last (Route Definition No's (1 ~ 6)⁶ From Program 54)

SELECT	DATA (Route Choices)						
Schedule 1 Route Choices For Plan <u>16</u>	16	1	1				
	16	1	2				
	16	1	3				
	16	1	4				
	16	1	5				
	16	1	6				
	16	1	7				
	16	1	8				
Schedule 2 Route Choices For Plan <u>16</u>	16	2	1				
	16	2	2				
	16	2	3				
	16	2	4				
	16	2	5				
	16	2	6				
	16	2	7				
	16	2	8				
Schedule 3 Route Choices For Plan <u>16</u>	16	3	1				
	16	3	2				
	16	3	3				
	16	3	4				
	16	3	5				
	16	3	6				
	16	3	7				
	16	3	8				

LCR Plan Schedule (1 ~ 3) LCR Station Group No. (1 ~ 8)⁵ (see Program 56)

1st 2nd 3rd Last (Route Definition No's (1 ~ 6)⁶ From Program 54)

NOTES:

1. For more information, see the instructions preceding the record sheets.
2. Initialized data assigns starting time as 0000 and Route Definitions as blank for all schedules.
3. If Schedules 1 & 2 start at the same time, then Time of Day schedule change does not occur, and data only needs to be entered for Schedule 1.
4. Press Button/LED 01 to erase data (LED does not light)
5. RCTUA and RCTUB provides 4 LCR station groups, RCTU C/D provides 8 LCR station groups
6. RCTUA and RCTUB provides 4 route definition Nos., RCTU C/D provides 6 route definition Nos.

PROGRAM 54 — LCR ROUTE DEFINITION TABLES (1 ~ 8)

###1*2*3 - Spkr 54 Hold - Spkr - - - Hold - Spkr ## Hold - Spkr ## Hold

SELECT = CODE =

Enter Data CODE = CO line group and modified digits table

SELECT =

Route Definition Table for LCR Plan → [01] (Note 3)

0	1	1	0	1	0	1
0	1	2				
0	1	3				
0	1	4				
0	1	5				
0	1	6				

Route Definition Table for LCR Plan → [02]

0	2	1				
0	2	2				
0	2	3				
0	2	4				
0	2	5				
0	2	6				

Route Definition Table for LCR Plan → [03]

0	3	1				
0	3	2				
0	3	3				
0	3	4				
0	3	5				
0	3	6				

Route Definition Table for LCR Plan → [04]

0	4	1				
0	4	2				
0	4	3				
0	4	4				
0	4	5				
0	4	6				

LCR Plan No. (1 ~ 4)

Route Definition Number

CO Line Group 1 ~ 16, see Program 16

Modified Digits Table 1 ~ 12, see Program 55

Enter Data CODE = CO line group and modified digits table

SELECT =

Route Definition Table for LCR Plan → [05] (Note 3)

0	5	1				
0	5	2				
0	5	3				
0	5	4				
0	5	5				
0	5	6				

Route Definition Table for LCR Plan → [06]

0	6	1				
0	6	2				
0	6	3				
0	6	4				
0	6	5				
0	6	6				

Route Definition Table for LCR Plan → [07]

0	7	1				
0	7	2				
0	7	3				
0	7	4				
0	7	5				
0	7	6				

Route Definition Table for LCR Plan → [08]

0	8	1	0	1	0	1
0	8	2				
0	8	3				
0	8	4				
0	8	5				
0	8	6				

LCR Plan No. (5 ~ 8)

Route Definition Number³

CO Line Group 1 ~ 16, see Program 16

Modified Digits Table 1 ~ 12, see Program 55

NOTES:

1. For more information, see the instructions preceding the record sheets.
2. Initialized data is "0101".
3. RCTUA and RCTUB provides 4 and RCTU C/D provides 6 route definition numbers.

PROGRAM 54 — LCR ROUTE DEFINITION TABLES (9 ~ 16, RCTU C/D ONLY)

##1*2*3 - Spkr 5 4 Hold - Spkr - - - Hold - Spkr ## Hold - Spkr ## Hold

SELECT = _____ CODE = _____

Enter Data

CODE = CO line group and modified digits table

SELECT = _____

Route Definition Table for LCR Plan → **09**

0	9	1			
0	9	2			
0	9	3			
0	9	4			
0	9	5			
0	9	6			

(Note 3)

Route Definition Table for LCR Plan → **10**

1	0	1			
1	0	2			
1	0	3			
1	0	4			
1	0	5			
1	0	6			

Route Definition Table for LCR Plan → **11**

1	1	1			
1	1	2			
1	1	3			
1	1	4			
1	1	5			
1	1	6			

Route Definition Table for LCR Plan → **12**

1	2	1			
1	2	2			
1	2	3			
1	2	4			
1	2	5			
1	2	6			

LCR Plan No. (9 ~ 12)

Route Definition Number

Modified Digits Table 1 ~ 12, see Program 55

CO Line Group 1 ~ 16, see Program 16

Enter Data

CODE = CO line group and modified digits table

SELECT = _____

Route Definition Table for LCR Plan → **13**

1	3	1			
1	3	2			
1	3	3			
1	3	4			
1	3	5			
1	3	6			

(Note 3)

Route Definition Table for LCR Plan → **14**

1	4	1			
1	4	2			
1	4	3			
1	4	4			
1	4	5			
1	4	6			

Route Definition Table for LCR Plan → **15**

1	5	1			
1	5	2			
1	5	3			
1	5	4			
1	5	5			
1	5	6			

Route Definition Table for LCR Plan → **16**

1	6	1			
1	6	2			
1	6	3			
1	6	4			
1	6	5			
1	6	6			

LCR Plan No. (13 ~ 16)

Route Definition Number

Modified Digits Table 1 ~ 12, see Program 55

CO Line Group 1 ~ 16, see Program 16

NOTES:

1. For more information, see the instructions preceding the record sheets.
2. Initialized data is "0101".
3. RCTUA and RCTUB provides 4 and RCTU C/D provides 6 route definition numbers.

PROGRAMMING PROCEDURES — RECORD SHEETS

SECTION 100-280-303

PROGRAM 55-0 — LCR MODIFIED DIGITS TABLE (DELETE FROM FRONT)

##1*2*3 - Spkr 5 5 Hold - Spkr [] [] 0 [] [] Hold - Spkr ## Hold - Spkr ## Hold

SELECT = Modified Digits Table 01 ~ 12 (twelve available).
 FIGURE = Quantity of Digits (00 ~ 10) to be deleted.

PROGRAM 55-1 and 2 LCR MODIFIED DIGITS TABLE (ADD)

##1*2*3 - Spkr 5 5 Hold - Spkr [] [] [] ... Hold - Spkr ## Hold - Spkr ## Hold

SELECT = Modified Digits Table (01 ~ 12)
 Enter 1 to add digits in front of number dialed
 Enter 2 to add digits at end of number dialed
 CODE = Digits added (up to 22). Enter the digits to be added. Pauses may be coded as described in the pause entry reference table below.

DELETE DIGITS TABLES

Table No.	Quantity of Digits
01	
02	
03	
04	
05	
06	
07	
08	
09	
10	
11	
12	

**PAUSE ENTRY REFERENCE
(Program 55-1, 55-2)**

LED	Pause (Seconds)	Record Entry
08	16	P8
07	14	P7
06	12	P6
05	10	P5
04	8	P4
03	6	P3
02	4	P2
01	2	P1

Special Buttons
 Button/LED
 11 - Clear
 10 - Convert DP to DTMF

Quantity 10 Max. (00 ~ 10)

ADD DIGIT TABLES

Add to FRONT of Dialed Number (Program 55-1)

Table No.	1	2	3	4	5	6	7	8	9	10	11	12	13	14	15	16	17	18	19	20	21	22	Comments	
01	9																							
02	9	1	0	1	0	6	1	4																
03																								
04																								
05																								
06																								
07																								
08																								
09																								
10																								
11																								
12																								

Add to END of Dialed Number (Program 55-2)

Table No.	1	2	3	4	5	6	7	8	9	10	11	12	13	14	15	16	17	18	19	20	21	22	Comments	
01																								
02																								
03																								
04																								
05																								
06																								
07																								
08																								
09																								
10																								
11																								
12																								

NOTES:

1. Initialized data leaves all tables blank except Delete Digits, which are all 00.
2. RCTUA and RCTUB provide 6 modified/add/delete digit tables, RCTU C/D provide 12 modified/add/delete tables.

PROGRAMMING PROCEDURES — RECORD SHEETS

PROGRAM 56 — LCR STATION GROUP ASSIGNMENTS (PORTS 121 ~ 239)

##1*2*3 - Spkr 5 6 Hold - Spkr # Hold - Spkr ## Hold - Spkr ## Hold

SELECT = Port Number(s) _____ Enter LCR Station Group (1 ~ 8)
 Enter port numbers of stations being assigned.
 See Note 3 for entering a range of ports.

Port Number	LCR Station Group No. (1 ~ 8)	Port Number	LCR Station Group No. (1 ~ 8)	Port Number	LCR Station Group No. (1 ~ 8)	Port Number	LCR Station Group No. (1 ~ 8)
121		152		183		214	
122		153		184		215	
123		154		185		216	
124		155		186		217	
125		156		187		218	
126		157		188		219	
127		158		189		220	
128		159		190		221	
129		160		191		222	
130		161		192		223	
131		162		193		224	
132		163		194		225	
133		164		195		226	
134		165		196		227	
135		166		197		228	
136		167		198		229	
137		168		199		230	
138		169		200		231	
139		170		201		232	
140		171		202		233	
141		172		203		234	
142		173		204		235	
143		174		205		236	
144		175		206		237	
145		176		207		238	
146		177		208		239	
147		178		209			
148		179		210			
149		180		211			
150		181		212			
151		182		213			

NOTES:

1. Initialized data assigns all stations to Group 1.
2. For more information, see the instructions preceding the records sheets.
3. To enter a range of ports, press: *
4. Refer to **Program 53**.
 Low port in range High port in range
5. RCTUA and RCTUB provides 4 LCR station groups, RCTU C/D provides 8 LCR station groups.

TABLE 2-B — ACCOUNT CODE PROGRAM OPTION MATRIX

Account Code Dial Plan	Account Code Program Options		
	Station		CO Line
	Verified Program 30 LED 14	Forced Program 30 LED 08	Forced Program 15-7 CO LED
Verified (Forced)	On	On	On
Verified (Voluntary)	On	On	Off
Verified (Voluntary)	On	Off	On
Verified (Voluntary)	On	Off	Off
Not Verified (Forced)	Off	On	On
Not Verified (Voluntary)	Off	On	Off
Not Verified (Voluntary)	Off	Off	On
Not Verified (Voluntary)	Off	Off	Off

System Initialization

TABLE 2-C — OVERRIDE OPTION MATRIX

Station A May Override Station B ¹		Privacy Override Station A Options	Privacy Override Block Station B Options	Station B Button Options (Program 39)	
Executive ³	Privacy	Program 30 ³ LED 19	Program 31 LED 18	Privacy ² Button	Privacy Release ² Button
Yes	No	Off	Off	Off	Off
Yes	Yes	Off	Off	Off	On
Yes	No	Off	Off	On	Off
Yes	Yes	Off	Off	On	On
No	No	Off	On	Off	Off
No	Yes	Off	On	Off	On
No	No	Off	On	On	Off
No	Yes	Off	On	On	On
Yes	Yes	On	Off	Off	Off
Yes	Yes	On	Off	Off	On
Yes	No	On	Off	On	Off
Yes	Yes	On	Off	On	On
No	No	On	On	Off	Off
No	Yes	On	On	Off	On
No	No	On	On	On	Off
No	Yes	On	On	On	On

NOTES:

1. **Station A** attempts to override (Executive or Privacy) **Station B**.
2. Normally either just a **Privacy on Line (PRIVACY)** or a **Privacy Release (PRVRLS)** is assigned to a telephone (Program 39) depending on how it should operate with Privacy Override.
3. **Program 30**, Button/LED 18 is ON for **Station A**, allowing **Station A** to have executive override to **Station B** for some possibilities in this table. If **Program 30**, LED 18 is OFF for **Station A**, then it can never executive override any station.

